



An Oshkosh Corporation Company

Service & Maintenance Manual

Models

R2632

R3246

PVC 2004

31217147

September 28, 2020 - Rev B

ANSI CE



AS/NZS GB



An Oshkosh Corporation Company

SECTION A. INTRODUCTION - MAINTENANCE SAFETY PRECAUTIONS

GENERAL

This section contains the general safety precautions which must be observed during maintenance of the Mobile Elevating Work Platform (MEWP). It is of utmost importance that maintenance personnel pay strict attention to these warnings and precautions to avoid possible injury to themselves or others, or damage to the equipment. A maintenance program must be followed to ensure that the machine is safe to operate.

⚠ WARNING

MODIFICATION OR ALTERATION OF A MOBILE ELEVATING WORK PLATFORM SHALL BE MADE ONLY WITH WRITTEN PERMISSION FROM THE MANUFACTURER.

The specific precautions to be observed during maintenance are inserted at the appropriate point in the manual. These precautions are, for the most part, those that apply when servicing hydraulic and larger machine component parts.

Your safety, and that of others, is the first consideration when engaging in the maintenance of equipment. Always be conscious of weight. Never attempt to move heavy parts without the aid of a mechanical device. Do not allow heavy objects to rest in an unstable position. When raising a portion of the equipment, ensure that adequate support is provided.

⚠ WARNING

SINCE THE MACHINE MANUFACTURER HAS NO DIRECT CONTROL OVER THE FIELD INSPECTION AND MAINTENANCE, SAFETY IN THIS AREA RESPONSIBILITY OF THE OWNER/OPERATOR.

HYDRAULIC SYSTEM SAFETY

It should be noted that the machines hydraulic systems operate at extremely high potentially dangerous pressures. Every effort should be made to relieve any system pressure prior to disconnecting or removing any portion of the system.

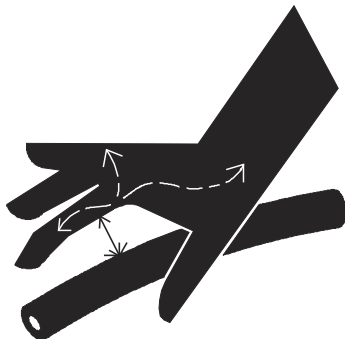

MAINTENANCE

⚠ WARNING

FAILURE TO COMPLY WITH SAFETY PRECAUTIONS LISTED IN THIS SECTION COULD RESULT IN MACHINE DAMAGE, PERSONNEL INJURY OR DEATH AND IS A SAFETY VIOLATION.

- USE ONLY REPLACEMENT PARTS OR COMPONENTS THAT ARE APPROVED BY JLG. TO BE CONSIDERED APPROVED, REPLACEMENT PARTS OR COMPONENTS MUST BE IDENTICAL OR EQUIVALENT TO ORIGINAL PARTS OR COMPONENTS.
- NO SMOKING IS MANDATORY. NEVER REFUEL DURING ELECTRICAL STORMS. ENSURE THAT FUEL CAP IS CLOSED AND SECURE AT ALL OTHER TIMES.
- REMOVE ALL RINGS, WATCHES AND JEWELRY WHEN PERFORMING ANY MAINTENANCE.
- DO NOT WEAR LONG HAIR UNRESTRAINED, OR LOOSE-FITTING CLOTHING AND NECKTIES WHICH ARE APT TO BECOME CAUGHT ON OR ENTANGLED IN EQUIPMENT.
- OBSERVE AND OBEY ALL WARNINGS AND CAUTIONS ON MACHINE AND IN SERVICE MANUAL.
- KEEP OIL, GREASE, WATER, ETC. WIPED FROM STANDING SURFACES AND HAND HOLDS.
- USE CAUTION WHEN CHECKING A HOT, PRESSURIZED COOLANT SYSTEM.
- NEVER WORK UNDER AN ELEVATED SCISSOR UNTIL PLATFORM HAS BEEN SAFELY RESTRAINED FROM ANY MOVEMENT BY BLOCKING OR OVERHEAD SLING, OR SAFETY PROP HAS BEEN ENGAGED.
- BEFORE MAKING ADJUSTMENTS, LUBRICATING OR PERFORMING ANY OTHER MAINTENANCE, SHUT OFF ALL POWER CONTROLS.
- BATTERY SHOULD ALWAYS BE DISCONNECTED DURING REPLACEMENT OF ELECTRICAL COMPONENTS.
- KEEP ALL SUPPORT EQUIPMENT AND ATTACHMENTS STOWED IN THEIR PROPER PLACE.
- USE ONLY APPROVED, NONFLAMMABLE CLEANING SOLVENTS.

REVISION LOG

Original Issue	A - April 15, 2020
Revised	B - September 28, 2020

SECTION NO.	TITLE	PAGE NO.
SECTION A	- INTRODUCTION - MAINTENANCE SAFETY PRECAUTIONS	
	General	A-1
	Hydraulic System Safety	A-1
	Maintenance	A-1
SECTION 1	- SPECIFICATIONS	
1.1	Operating Specification	1-1
	Machine Specification	1-1
	Platform Capacities	1-2
	Machine Dimensional Data	1-2
	Tires	1-2
	Batteries	1-3
	Motors	1-3
	Battery Charger	1-4
1.2	Limit Switch Activation	1-5
	Tilt Alarm	1-5
1.3	Lubrication	1-5
	Capacities	1-5
	Specifications	1-5
1.4	Hydraulic Oil	1-6
1.5	Hydraulic Pressure Settings	1-8
1.6	Hydraulic Cylinder Specifications	1-8
1.7	Serial Number Location	1-8
1.8	Critical Stability Weights	1-8
1.9	Major Component Weights	1-9
1.10	Torque Requirements	1-9
1.11	Thread Locking Compound	1-10
1.12	Torque Charts	1-11
	SAE Fastener Torque Chart	1-11
	Metric Fastener Torque Chart	1-17
SECTION 2	- GENERAL	
2.1	Machine Preparation, Inspection, and Maintenance	2-1
	General	2-1
	Preparation, Inspection, and Maintenance	2-1
	Pre-Start Inspection	2-1
	Pre-Delivery Inspection and Frequent Inspection	2-1
	Annual Machine Inspection	2-1
	Preventative Maintenance	2-1
2.2	Preventive Maintenance and Inspection Schedule	2-3
	Maintenance and Inspection Schedule Codes:	2-3
2.3	Service Maintenance Components	2-7
	Scissor Arm - Safety Prop	2-8
	Hydraulic Oil Check Procedure	2-9

TABLE OF CONTENTS

SECTION NO.	TITLE	PAGE NO.
2.4	Service and Guidelines	2-10
	General	2-10
	Safety and Workmanship	2-10
	Cleanliness	2-10
	Components Removal and Installation	2-11
	Component Disassembly and Reassembly	2-11
	Pressure-Fit Parts	2-11
	Bearings	2-11
	Gaskets	2-11
	Bolt Usage and Torque Application	2-11
	Hydraulic Lines and Electrical Wiring	2-11
	Hydraulic System	2-11
	Lubrication	2-11
	Battery	2-11
2.5	Lubrication and Information	2-12
	Hydraulic System	2-12
	Hydraulic Oil	2-12
	Changing Hydraulic Oil	2-12
2.6	Cylinder Drift Test	2-13
	Platform Drift	2-13
	Cylinder Drift	2-13
2.7	Pins and Composite Bearing Repair Guidelines	2-13
SECTION 3 - CHASSIS & SCISSOR ARMS		
3.1	Left and Right Side Compartment Components	3-1
3.2	Battery Removal/Maintenance	3-4
	Battery Quick-Disconnect	3-4
	Battery Maintenance and Safety Practices	3-5
3.3	Battery Charging	3-5
	Delta-Q - Battery Charger	3-6
	Green Power - Battery Charger - (China (GB) Only)	3-6
	Eagle Performance - Battery Charger	3-7
	Battery Charger Maintenance	3-7
3.4	DC/AC Power Inverter Installation - Option	3-11
3.5	Logic Control Module Installation	3-12
	Module Access	3-12
	Removing Module from Machine	3-12
3.6	Main Power Contactor Relay and Pump Control Module	3-13
3.7	Pump Control Module	3-14
	Removal	3-14
	Installation	3-14
3.8	Ground Control Station	3-16
	Components Location	3-16
	Removal	3-16
	Installation	3-16
3.9	Platform Control Station	3-18
	Overview of Control Station Components	3-18
	Installation/Removal	3-19
	Control Station Disassembly	3-19
	Joystick Controller	3-21
3.10	Tilt Sensor Installation	3-22
	Tilt Sensor Removal	3-22
	Tilt Sensor Installation	3-22
3.11	Arm Angle Sensor	3-23
	Arm Angle Sensor Installation	3-24
3.12	PotHole Protection System Components	3-26

SECTION NO.	TITLE	PAGE NO.
3.13	Steer And Spindle Assembly Components	3-29
	Drive Motor Covers Installation - Option	3-31
	Tire Wear and Damage	3-32
	Wheel and Tire Replacement	3-32
	Wheel Installation	3-32
3.14	Arms and Platform Positioning and Support	3-33
3.15	Platform Removal	3-33
3.16	Scissor Arms Removal	3-33
	Removing Scissor Arm Assembly as a Complete Unit	3-33
	Removing/Installing Scissor Arms Individually	3-33
 SECTION 4 - BASIC HYDRAULICS INFORMATION & SCHEMATICS		
4.1	Cylinders - Theory of Operation	4-1
4.2	Valves - Theory of Operation	4-1
	Solenoid Control Valves (Bang-Bang)	4-1
	Relief Valves	4-1
	Crossover Relief Valves	4-1
	Proportional Valve	4-1
	Manual Descent Valve	4-1
4.3	Pump/Motor	4-2
	Pump Motor Electrical Evaluation	4-2
4.4	Hydraulic Tank Installation	4-4
4.5	Hydraulic Pump And Electric Motor Assembly - R3246	4-5
	Pump/Motor Removal	4-5
4.6	Hydraulic Pump and Electric Motor Assembly - R2632	4-6
	Pump/Motor Removal	4-6
	Pump/Motor Disassembly	4-7
	Pump/Motor Assembly	4-7
	Pump/Motor Installation	4-7
4.7	Hydraulic Manifold Valve Installation	4-9
4.8	Drive Motor Installation	4-15
4.9	Hydraulic Brake Installation	4-16
4.10	Towing	4-17
	Hydraulic Brake Release for Towing	4-17
4.11	Pressure Setting Procedure	4-17
	Machine Model Pressure setting	4-17
	Main Relief	4-17
	Lift Up Relief	4-18
	Steer Relief	4-18
4.12	Cylinder Checking Procedure	4-19
4.13	Lift Cylinder Removal Installation	4-19
	Lift Cylinder - LSS Pressure Sensor Location	4-20
4.14	Cylinder Repair	4-24
	Disassembly	4-24
	Cleaning and Inspection	4-25
	Assembly	4-26
4.15	Hydraulic Schematics	4-30
 SECTION 5 - JLG CONTROL SYSTEM		
5.1	Hand Held Analyzer	5-1
	Diagnostic Port	5-1
	To Connect the Hand Held Analyzer:	5-1
	Using the Analyzer:	5-2
	Changing the Access Level of the Hand Held Analyzer:	5-3
	Adjusting Parameters Using the Hand Held Analyzer	5-4
	Machine Setup	5-4
5.2	Joystick Calibration	5-5

TABLE OF CONTENTS

SECTION NO.	TITLE	PAGE NO.
5.3	Tilt Sensor Calibration	5-5
	Tilt Sensor Failure Troubleshooting	5-6
5.4	Rotary Angle Sensor Calibration.....	5-6
5.5	Updating Software	5-6
5.6	Machine Configuration Programming Information	5-13
5.7	Machine Model Adjustment (Personality Settings)	5-14
SECTION 6 - LSS (LOAD SENSING SYSTEM) SERVICE		
6.1	LSS (Load Sensing System).....	6-1
	Theory of Operation	6-1
6.2	Analyzer Information	6-3
	Personalities Menu	6-3
	Diagnostic Menu	6-3
6.3	Calibration Preparation	6-5
6.4	Calibration And Verification Procedure	6-6
	Empty Platform Calibration	6-6
	Loaded Platform Calibration	6-6
	LSS Verification.....	6-7
	Partial Height Calibration	6-7
6.5	Testing.....	6-7
6.6	LSS Connector Pin Assignments.....	6-8
6.7	LSS Troubleshooting	6-9
	LSS Troubleshooting	6-9
SECTION 7 - DIAGNOSTIC TROUBLE CODES		
7.1	Introduction.....	7-1
	System Fault/DTC Indication	7-1
7.2	Diagnostic Trouble Codes (DTC)	7-1
7.3	DTC Check Tables	7-2
SECTION 8 - BASIC ELECTRICAL INFORMATION & SCHEMATICS		
8.1	General	8-1
8.2	Multimeter Basics	8-1
	Grounding	8-1
	Backprobing	8-1
	Min/Max	8-1
	Polarity	8-1
	Scale.....	8-1
	Voltage Measurement	8-2
	Resistance Measurement	8-2
	Continuity Measurement	8-3
	Current Measurement	8-3
	Continuity Measurement Over Long Distances	8-4
	Requirements:.....	8-4
	Procedure.....	8-4
8.3	Applying Silicone Dielectric Compound to AMP Connectors	8-4
8.4	Dielectric Grease Application	8-5
	Installation	8-5
	AMP Mate-N-Lok	8-5
	AMP Faston	8-5
	AMP Micro-Fit	8-5
	AMP Mini Fit Jr	8-5
	Mini Fit Sr	8-5
	DIN Connectors	8-6
	Exceptions	8-6

SECTION NO.	TITLE	PAGE NO.
8.5	AMP Connector	8-7
	Assembly	8-7
	Disassembly	8-9
	Wedge Lock	8-9
	Service - Voltage Reading	8-9
8.6	Deutsch Connectors	8-11
	DT/DTP Series Assembly.....	8-11
	DT/DTP Series Disassembly.....	8-11
	HD30/HDP20 Series Assembly.....	8-12
	HD30/HDP20 Series Disassembly.....	8-12
8.7	Switches.....	8-13
	Basic Check	8-13
	Limit Switches	8-13
	Automatic Switches	8-13
	Switch Wiring - Low Side, High Side.....	8-13
8.8	Electrical Schematics	8-15

FIGURE NO.	TITLE	PAGE NO.
1-1.	Hydraulic Oil Operating Temperature Specifications	1-7
2-1.	Machine Component Locations - R3246	2-7
2-2.	Machine Component Locations - R2632	2-8
2-3.	Scissor Arm - Safety Prop	2-9
2-4.	Scissor Arm - Safety Prop	2-9
2-5.	Hydraulic Oil Check Procedure	2-10
2-6.	Hydraulic Oil Fill Procedure	2-10
3-1.	Components on Left Side Swing - Out Compartment Door (R2632 and R3246)	3-1
3-2.	Components on Right Side Swing - Out Compartment Door (R3246)	3-1
3-3.	Components on Right Side Swing - Out Compartment Door (R2632)	3-2
3-4.	Side Swing - Out Compartment Door Installation	3-3
3-5.	Battery Cable Connections	3-4
3-6.	Battery Fluid Level	3-5
3-7.	DC/AC Power Inverter - Installation	3-11
3-8.	Logic Module Components	3-12
3-9.	Logic Module CO01 - Harness Connector Identification	3-12
3-10.	Hydraulic Pump Control - Power Connections	3-15
3-11.	Ground Control Station Removal	3-17
3-12.	Ground Control Station - Rear of Panel	3-17
3-13.	Platform Control Station Components (R3246) - External	3-18
3-14.	Platform Control Station Components (R2632) - External	3-18
3-15.	Platform Control Station Installation	3-19
3-16.	Platform Control Station Disassembly	3-19
3-17.	Platform Control Station Components (R3246) - Internal	3-20
3-18.	Platform Control Station Components (R2632) - Internal	3-20
3-19.	Joystick	3-21
3-20.	Tilt Sensor Installation	3-22
3-21.	Angle Sensor Orientation	3-24
3-22.	PotHole Protection Assembly (R3246)	3-26
3-23.	PotHole Protection Assembly (R2632)	3-27
3-24.	Steer and Spindle Assembly Installation (R3246)	3-29
3-25.	Steer and Spindle Assembly Installation (R2632)	3-30
3-26.	Drive Motor Cover Installation - Option	3-31
3-27.	Wheel Installation	3-32
3-28.	Arms and Platform Positioning with Overhead Support	3-34
3-29.	Platform Assembly - Installation/Removal	3-35
3-30.	Scissor Arm Assembly (R3246)	3-36
3-31.	Scissor Arm Assembly - Pin Configuration (R3246)	3-37
3-32.	Scissor Arm Assembly (R2632)	3-38
3-33.	Scissor Arm Assembly - Pin Configuration (R2632)	3-39
3-34.	Scissor Arm Assembly (R3246) - Cable Routing	3-40
3-35.	Scissor Arm Assembly (R3246) - Cable Routing (Coiled)	3-41
3-36.	Scissor Arm Assembly (R3246) - Cable Routing (With Foot Switch)	3-42
3-37.	Scissor Arm Assembly (R3246) - Cable Routing (Coiled) (With Foot Switch)	3-43
3-38.	Scissor Arm Assembly (R2632) - Cable Routing	3-44
3-39.	Scissor Arm Assembly (R2632) - Cable Routing (Coiled)	3-45
3-40.	Scissor Arm Assembly (R2632) - Cable Routing (With Foot Switch)	3-46
3-41.	Scissor Arm Assembly (R2632) - Cable Routing (Coiled) (With Foot Switch)	3-47
4-1.	Hydraulic Pump - Motor Components	4-5
4-2.	Hydraulic Pump - Motor Components	4-6
4-3.	Hydraulic Pump (R3246) - Motor Components	4-7
4-4.	Hydraulic Pump (R2632) - Motor Components	4-8
4-5.	Hydraulic Manifold Assembly - Installation	4-9
4-6.	Hydraulic Manifold Assembly - Schematic (1001215433)	4-9
4-7.	Hydraulic Manifold Assembly - Schematic (1001248679)	4-10
4-8.	Hydraulic Manifold Assembly - Component Location	4-11
4-9.	Hydraulic Manifold Assembly - Component Torque	4-12

FIGURE NO.	TITLE	PAGE NO.
4-10.	Hydraulic Hose Routing (R3246)	4-13
4-11.	Hydraulic Hose Routing (R2632)	4-14
4-12.	Drive Motor - Installation	4-15
4-13.	Hydraulic Brake - Installation	4-16
4-14.	Hydraulic Brakes - Manual Disengage	4-17
4-15.	LSS Pressure Sensor Location	4-20
4-16.	Lift Cylinder	4-21
4-17.	Steer Cylinder (R3246)	4-22
4-18.	Steer Cylinder (R2632)	4-23
4-19.	Cylinder Barrel Support	4-24
4-20.	Cylinder Rod Support	4-24
4-21.	Gar-Max Bearing Installation	4-25
4-22.	Rod Seal Installation	4-26
4-23.	Poly-Pak Piston Seal Installation	4-26
4-24.	Wiper Seal Installation	4-26
4-25.	Installation of Head Seal Kit	4-26
4-26.	Rod Assembly Installation	4-27
4-27.	Hydraulic Schematic (R3246) - Sheet 1 of 2	4-30
4-28.	Hydraulic Schematic (R3246) - Sheet 2 of 2	4-31
4-29.	Hydraulic Schematic (R2632) - Sheet 1 of 2	4-32
4-30.	Hydraulic Schematic (R2632) - Sheet 2 of 2	4-33
5-1.	Hand Held Analyzer	5-1
5-2.	Diagnostic Port Location	5-1
5-3.	Analyzer Menu - Help and Diagnostics (Version P1.13.1) - Sheet 1 of 6	5-7
5-4.	Analyzer Menu - Help and Diagnostics (Version P1.13.1) - Sheet 2 of 6	5-8
5-5.	Analyzer Menu - Help and Diagnostics (Version P1.13.1) - Sheet 3 of 6	5-9
5-6.	Analyzer Menu - Help and Diagnostics (Version P1.13.1) - Sheet 4 of 6	5-10
5-7.	Analyzer Menu - Help and Diagnostics (Version P1.13.1) - Sheet 5 of 6	5-11
5-8.	Analyzer Menu - Help and Diagnostics (Version P1.13.1) - Sheet 6 of 6	5-12
6-1.	LSS Component Locations	6-2
8-1.	Connector Assembly Figure 1	8-7
8-2.	AMP Connector	8-7
8-3.	Connector Assembly Figure 2	8-8
8-4.	Connector Assembly Figure 3	8-8
8-5.	Connector Assembly Figure 4	8-8
8-6.	Connector Disassembly	8-9
8-7.	Connector Installation	8-10
8-8.	DT/DTP Contact Installation	8-11
8-9.	DT/DTP Contact Removal	8-11
8-10.	HD/HDP Contact Installation	8-12
8-11.	HD/HDP Locking Contacts Into Position	8-12
8-12.	HD/HDP Contact Removal	8-12
8-13.	HD/HDP Unlocking Contacts	8-12
8-14.	Electrical Schematic - Sheet 1 of 9	8-15
8-15.	Electrical Schematic - Sheet 2 of 9	8-16
8-16.	Electrical Schematic - Sheet 3 of 9	8-17
8-17.	Electrical Schematic - Sheet 4 of 9	8-18
8-18.	Electrical Schematic - Sheet 5 of 9	8-19
8-19.	Electrical Schematic - Sheet 6 of 9	8-20
8-20.	Electrical Schematic - Sheet 7 of 9	8-21
8-21.	Electrical Schematic - Sheet 8 of 9	8-22
8-22.	Electrical Schematic - Sheet 9 of 9	8-23

LIST OF TABLES

TABLE NO.	TITLE	PAGE NO.
1-1	Battery Charger Specifications	1-4
1-2	Standard UTTO Hydraulic Fluid Specs	1-6
1-3	Biodegradable Synthetic Hydraulic Fluid (VG 32) Specs	1-6
2-1	Inspection and Maintenance Responsibilities	2-2
2-2	Preventive Maintenance & Inspection Schedule	2-4
3-1	Diagnostic Trouble Codes (Delta Q Battery Charger)	3-8
3-2	Fault Codes (Green Power)	3-9
3-3	Fault Codes (Eagle Battery Charger)	3-10
3-4	Pump Control Module Specifications	3-14
3-5	Pump Power Module Terminal Functions (CO117-J1)	3-14
3-6	Joystick Specifications	3-21
3-7	Connector Chart	3-21
3-8	Tilt Sensor Wiring Pin Assignment	3-22
4-1	Valve Pressure Per Machine Model	4-17
5-1	Machine Configuration Programming Information (Software Version P1.13.1)	5-13
5-2	Machine Model Adjustment (Software Version P1.13.1)	5-14
6-1	Personalities Menu Description	6-3
6-2	Diagnostic Menu Descriptions	6-4
6-3	Calibrations Menu	6-5
6-4	Platform 110% Calibration Weight	6-6
6-5	Platform 100% Calibration Weight	6-7
6-6	Platform 120% Calibration Weight	6-8
6-7	LSS Troubleshooting	6-9
7-1	Diagnostic Trouble Codes (DTC)	7-2

SECTION 1. SPECIFICATIONS

1.1 OPERATING SPECIFICATION

Machine Specification

DESCRIPTION	R3246	R2632
PLATFORM		
Maximum Working Height	38 ft. (11.6 m)	31.5 ft. (9.6 m)
Platform Lift Time (No Load)		
Lift Up:	42 sec	28-38 sec
Lift Down:	44 sec	32-40 sec
Platform Lift Time (Rated Load)		
Lift Up:	50 sec	32-46 sec
Lift Down:	37 sec	24-34 sec
Ground Clearance		
PHP Deployed	0.91 in. (23 mm)	0.91 in. (23 mm)
PHP Retracted	3.9 in. (98 mm)	3.9 in. (98 mm)
Breakover Angle (Retracted)	12°	12°
Occupied Floor Area	30.1 ft ² (2.80 m ²)	21.0 ft ² (1.95 m ²)
Electronic Arm Guard Pause Height (CE/GB only)	73 in. (1.85 m)	66 in. (1.68 m)
Electronic Arm Guard Height Lift Down Time (CE/GB only)	6 sec (approx.)	5 sec (approx.)
DRIVING		
Maximum Operating Slope (<i>platform fully elevated</i>)		
Front to Back:		3.5°
Side to Side:		1.5°
High Drive Speed (FWD/REV)	2.2 mph (3.5 kph)	2.0 mph (3.2 kph)
Elevated Drive Speed (FWD/REV)	0.5 mph (0.8 kph)	
Elevated Drive Platform Height	>62 in. (1.57 m)	55 in. (1.40 m)
Maximum Stowed Travel Grade (Sideslope)	8.75% (5°)	
Gradeability	25% / (14°)	
Turning Radius		
Inside:	0 in. (0 cm)	0 in. (0 cm)
(Curb to Curb) Outside:	88.5 in. (2.25 m)	82.2 in. (2.09 m)
(Wall to Wall) Outside:	93.3 in. (2.37 m)	86.9 in. (2.21 m)
CHASSIS		
Approximate Gross Machine Weight		
All Markets:	5410 lb (2454 kg)	4280 lb (1941 kg)
AUS Only:	5510 lb (2499 kg)	4280 lb (1941 kg)
Maximum Tire Load (per wheel)	2150 lb (975 kg)	1373 lb (623 kg)
Ground Bearing Pressure	131 psi (9.03 bar)	92 psi (6.34 bar)

SECTION 1 - SPECIFICATIONS

Platform Capacities

DESCRIPTION	R3246	R2632
Operating Personnel		
Indoor	2 persons	2 persons
Outdoor	1 person	1 person
Outdoor (AUS Only)	1 person	*
Platform Rated Load		
Indoor	705 lb (320 kg)	507 lb (230 kg)
Outdoor (All Markets)	507 lb (230 kg)	275 lb (125 kg)
Outdoor (AUS Only)	705 lb (320 kg)	*
Extension Deck Rated Load	265 lb (120 kg)	
Maximum Operating Wind Speed		
Indoor	0 mph (0 m/s)	
Outdoor	28 mph (12.5 m/s)	
Maximum Horizontal Side Force		
Indoor	90 lb (400 N)	
Outdoor	45 lb (200 N)	
NOTE:	(*) Machine R2632 does not have outdoor functionality in the AUS market.	
NOTE:	INDOOR USE is use of a MEWP in areas shielded from wind so that there is no wind. OUTDOOR USE is use of a MEWP in an environment that can be exposed to wind.	

Machine Dimensional Data

DESCRIPTION	R3246	R2632
Maximum Platform Height		
Indoor/Outdoor (All Market)	32 ft (9.75 m)	--
Indoor (All Market)	--	25.50ft (7.77m)
Outdoor (All Market Except AUS)	--	21ft (6.40m)
Overall Machine Height (Stowed)		
Telescope Rails	7.96 ft (2.43 m)	7.30 ft (2.23m)
Dual Rails	8.03 ft (2.45 m)	7.29 ft (2.22 m)
Rails Folded	6.47 ft (1.97 m)	5.81 ft (1.77m)
Overall Machine Height (Elevated)		
Telescope Rails	35.72 ft (10.89 m)	29.17 ft (8.89m)
Dual Rails	35.78 ft (10.91 m)	29.23 ft (8.91 m)
Platform Height (Ground to Platform Floor)		
Stowed	4.24 ft (1.29 m)	3.63 ft (1.11 m)
Elevated	32 ft (9.75 m)	25.50 ft (7.77m)
Safety Prop Engaged	8.50 ft (2.59 m)	7.15 ft (2.18 m)
Rail Height (Platform Floor to Top of Rail)		
Telescope Rails	3.72 ft (1.13 m)	3.66 ft (1.12 m)
Dual Rails	3.78 ft (1.15 m)	3.66 ft (1.12 m)
Overall Machine Width	3.83 ft (1.17 m)	2.67 ft (0.81 m)
Overall Machine Length	7.86 ft (2.40 m)	
Extension Deck Length	3 ft (0.91 m)	2.83 ft (0.86 m)
Wheelbase	6.18 ft (1.88 m)	

Tires

DESCRIPTION	R3246	R2632
Size	16 in. x5 in. (406 mm x127 mm)	
Wheel Nut Torque (2 in. (51mm) - Slotted Nut with Cotter Pin)	150 ft. lbs. (203 Nm)	

Batteries

DESCRIPTION	Lead Acid	Lead Acid (Extended Range)	AGM
Voltage (24V System)	6V per battery		
Amp Hour Rating	225 Ah @ 20HR rate	255 Ah @ 20HR rate	213 Ah
Reserve Capacity	447 Minutes	570 Minutes	492 min
Weight (each battery)	63 lb (28.6 kg)	75 lb (34 kg)	66 lb (30 kg)

NOTICE

JLG MACHINES EQUIPPED WITH DELTA Q BATTERY CHARGERS ARE DESIGNED FOR THE BEST PERFORMANCE WITH OEM FACTORY APPROVED BATTERIES.

APPROVED JLG REPLACEMENT BATTERIES ARE AVAILABLE THROUGH JLG'S AFTERMARKET PARTS DISTRIBUTION CENTERS OR JLG'S AFTERMARKET PROGRAMS. FOR ASSISTANCE WITH PROPER BATTERY REPLACEMENT, PLEASE CONTACT YOUR LOCAL JLG SUPPORT OFFICE.

BATTERIES APPROVED BY JLG HAVE BEEN TESTED FOR COMPATIBILITY WITH THE ALGORITHM PROGRAMMING OF THE DELTA Q BATTERY CHARGER TO OPTIMIZE BATTERY LIFE AND MACHINE CYCLE TIMES. THE USE OF NON-APPROVED BATTERIES IN YOUR JLG EQUIPMENT MAY RESULT IN PERFORMANCE ISSUES OR BATTERY CHARGER FAULT CODES. JLG ASSUMES NO RESPONSIBILITY FOR SERVICE OR PERFORMANCE ISSUES ARISING FROM THE USE OF NON-APPROVED BATTERIES.

Motors

• Drive Motors (R3246)

Type: Hydraulic

Displacement: 280 cc/rev (17.1 in³/rev)

Max. Torque: 6460 lb-in. (730 Nm) - Continuous

Max. Torque: 8218 lb-in. (929 Nm) - Intermittent

Min. Starting Torque: 5479 lb-in. (619 Nm) -
Continuous

Min. Starting Torque: 6967 lb-in. (787 Nm) -
Intermittent

Max. Power: 45 hp (34 kW)

Max. Oil Flow: 18 gpm (68 lpm) - Continuous

Max. Oil Flow: 25 gpm (95 lpm) - Intermittent

Max. Speed: 335 rev/min at Max. Intermittent
flow

• Drive Motors (R2632)

Type: Hydraulic

Displacement: 364 cc/rev (22.2 in.³/rev)

Max. Differential Pressure: 2500 psi (172 bar) -
Continuous

Max. Differential Pressure: 3500 psi (224 bar) -
Intermittent

Max. Differential Pressure: 4350 psi (300 bar) -
Peak

• Hydraulic Brake

Type: Hydraulic Release

Holding Torque: 10,000 lb-in. (1130 Nm)

Max. Speed: 250 rpm

Release Pressure: 406 psi (28 bar)

Max. Release Pressure: 3000 psi (207 bar)

Release Volume: 0.7 cu. in. (11.5 cc)

• Hydraulic Pump/Electric Motor (R3246)

Motor Type: 24V DC Wound Field

Motor Power: 4.5 kW

Pump Displacement: 0.226 cu in. /rev (3.7 cc/rev)

Pump Pressure: 3000 psi Peak
4000 psi Intermittent

• Hydraulic Pump/Electric Motor (R2632)

Motor Type: 24V DC Wound Field

Motor Power: 4.5 kW

Pump Displacement: 0.29 cu in. /rev (4.77 cc/rev)

Pump Pressure: 2100 psi Continuous
3500 psi Intermittent

Battery Charger

Table 1-1. Battery Charger Specifications

DESCRIPTION	R2632/R3246		
Electrical System Voltage (DC)	24V		
Battery Charger:	Delta-Q	PRO - Eagle Performance Series	Green Power - Pylon International
Input:			
AC Input Voltage:	85-270VAC	108-132VAC	100-240VAC
Nominal AC Input Voltage:	100VAC / 240VACRMS	120VACRMS	— —
Input Frequency:	50 - 60Hz	45 - 65Hz	45 - 65Hz
Max. AC Input Current:	7.5A	12A	8.5A
Ingress Protection:	IP66 NEMA4 Type 4	IP35	IP66
Operating Temperature:	-40°F (-40°C) to 149°F (+65°C)	-22°F (-30°C) to 122°F (+50°C)	-4°F (-20°C) to 122°F (+50°C)
Output:			
Nominal DC Output Voltage:	24V	24V	24V
Max. DC Output Voltage:	36V	31.92V	34V
Max DC Output Current:	27.1A	25A	30A
Max. Interlock Current:	1A @ 24V	1A @ 24V	1A @ 24V
Protection:			
Output Reverse Polarity:	Electronic Protection - Auto Reset	Electronic Protection - Auto Reset	Electronic Protection - Auto Reset
Output Short Circuit:	Current Limited	Electronic Protection - Auto Reset	Electronic Protection - Auto Reset
AC Overload:	Current Limited	Branch Circuit Protection	Current Limited
DC Overload:	Current Limited	Current Limited	Current Limited

1.2 LIMIT SWITCH ACTIVATION

Tilt Alarm

NOTE: When the tilt indicator warning is activated the following functions are affected;

Platform Lowered: Only Drive Allowed.

Platform Raised: Drive and lift up functions are disabled, platform must be fully lowered (stowed) to drive out of tilt condition.

MODEL	Tilt Setting Y-Axis (Front To Back)	Tilt Setting X-Axis (Side To Side)	Platform Height
R3246 ANSI EXP ANSI USA CSA / KOR CE,JPN, CHN(GB)	3.5°	1.50° - outdoor 2.50° - indoor	27 - 32 ft (8.23 - 9.75 m)
		2.25° - outdoor 2.75° - indoor	22 - 27 ft (6.7 - 8.23 m)
		3.50° - outdoor 3.75° - indoor	5.4 - 22 ft (1.65 - 6.7 m)
R3246 AUS	3.5°	1.50° - outdoor 1.50° - indoor	27 - 32 ft (8.23 - 9.75 m)
		2.25° - outdoor 2.25° - indoor	22 - 27 ft (6.7 - 8.23 m)
		3.50° - outdoor 3.50° - indoor	5.4 - 22 ft (1.65 - 6.7 m)
R2632	3.5°	1.50° - outdoor 1.50° - indoor	18 - 21 ft (5.84 - 6.4 m) 20.5 - 26 ft (6.2 - 7.9 m)
		2.50° - outdoor 2.25° - indoor	14 - 18 ft (4.2 m - 5.4 m) 16.5 - 20.5 ft (5 m - 6.2 m)
		4.50° - outdoor 3.50° - indoor	55 in. - 14 ft (1.4 m - 4.3 m) 55 in. - 16.5 ft (1.4 m - 5 m)

1.3 LUBRICATION

Capacities

COMPONENT	R3246	R2632
Hydraulic Reservoir (at Full mark)	4 gal (15 L)	
Hydraulic System (Including Reservoir)	5.5 gal (21 L)	4.75 gal (18 L)

Specifications

KEY	SPECIFICATIONS
MPG	Multipurpose Grease having a minimum dripping point of 350° F. Excellent water resistance and adhesive qualities, and being of extreme pressure type. (Timken OK 40 pounds minimum.)
EPGL	Extreme Pressure Gear Lube (oil) meeting API service classification GL-5 or MIL-Spec MIL-L-2105.
HO	JLG Recommends - Standard Hydraulic Fluid UTTO Bio Synthetic Hydraulic Fluid (VG 32) <i>EAL and SHC are compatible with each other.</i>

NOTE: Aside from JLG recommendations, it is not advisable to mix oils of different brands or types, as they may not contain the same required additives or be of comparable viscosities.

1.4 HYDRAULIC OIL

Table 1-2. Standard UTTO Hydraulic Fluid Specs

Inspection Data	Recommended SHELL SPIRAX S4 TXM	Optional MOBILFLUID 424
ISO Viscosity Grade	68	68
Spec Gravity API	0.882	0.880
Flash Point, ° F (° C)	428°F (220°C)	442.4°F (228°C)
Pour Point, ° F (° C)	-43.6°F (-42°C)	-45.4°F (-43°C)
Base Oil Type	HV	HV
Viscosity		
Brookfield, cP at -4°F (-20°C)	-	4300
Brookfield, cP at 23°F (-5°C)	-	-
Viscosity, cST at 104°F (40°C)	66.93	60.21
Viscosity, cST at 212°F (100°C)	10.53	9.26
Viscosity Index	146	134

Table 1-3. Biodegradable Synthetic Hydraulic Fluid (VG 32) Specs

Inspection Data	Recommended SHELL NATURELLE HF-E32	Optional MOBIL EAL ENVIRONSYN H32
ISO Viscosity Grade	32	32
Spec Gravity API	0.918	0.869
Flash Point, ° F (° C)	475°F (246°C)	514 °F (268°C)
Pour Point, ° F (° C)	-38 °F (-39°C)	-38°F (-39°C)
Base Oil Type	POLYOL ESTER	FATTY ACID ESTER
	HEES	-
	HFDU	-
Auto-Ignition Temp, ° F (° C)	>608°F (>320°C)	-
Biodegradability (% 28 Days)	79%	>60%
Viscosity		
Brookfield, cP at -22°F (-30°C)	-	-
Brookfield, cP at -4°F (-20°C)	-	-
Brookfield, cP at 23°F (-5°C)	-	-
Viscosity, cST at 104°F (40°C)	30.78	33.59
Viscosity, cST at 212°F (100°C)	6.85	6.41
Viscosity Index	192	146

Specified lubricants, as recommended by the component manufacturers, are always the best choice, however, multi-purpose greases usually have the qualities which meet a variety of single purpose grease requirements.

Should any question arise, regarding the use of greases in maintenance stock, consult your local supplier for evaluation. Refer to Specifications on page 1-5 for an explanation of the lubricant key designations.

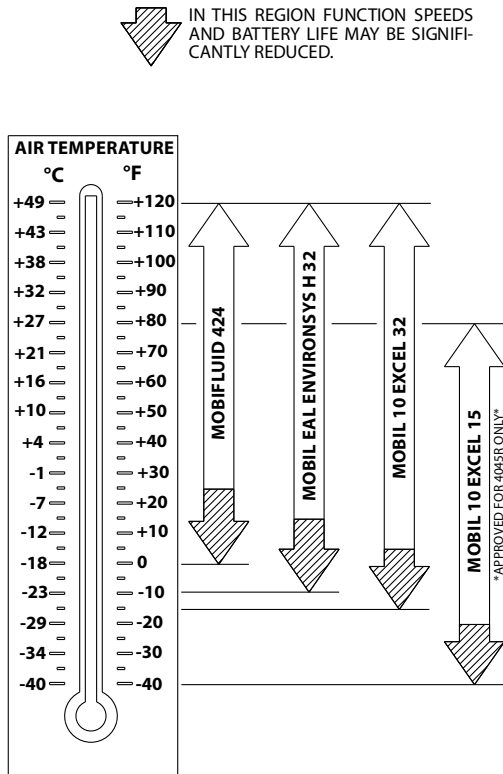

Fluid	Properties		Base				Classifications		
	Viscosity at 40°C (Cst, Typical)	Viscosity Index	Mineral Oils	Vegetable Oils	Synthetic	Synthetic Polyol Esters	Readily Biodegradable*	Virtually Non-toxic**	Fire Resistant***
Mobil fluid 424	55	145	x						
Mobil EAL EnviroSyn H 32	33	147			x		x		
Mobil DTE 10 Excel 32	32	164	x					x	
Mobil DTE 10 Excel 15	15	168	x					x	

* Readily biodegradable classification indicates one of the following:

CO2 Conversion >60% per EPA 56016-82-003

CO2 Conversion >80% per CEC-L-33-A-93

** Virtually Non-toxic classification indicates an LC50 >5000 ppm per OECD 203

*** Fire Resistant classification indicates Factory Mutual Research

Corp. (FMRC) Approval

NOTICE:

MACHINE OPERATION USING NON-JLG APPROVED HYDRAULIC FLUIDS OR OPERATION OUTSIDE OF THE TEMPERATURE BOUNDARIES OUTLINED IN THE "HYDRAULIC FLUID OPERATION CHART" MAY RESULT IN PREMATURE WEAR OR DAMAGE TO COMPONENTS OF THE HYDRAULIC SYSTEM.

1001219909-E
MAF11160E

Figure 1-1. Hydraulic Oil Operating Temperature Specifications

SECTION 1 - SPECIFICATIONS

1.5 HYDRAULIC PRESSURE SETTINGS

MODEL	MAIN RELIEF	LIFT RELIEF	STEER RELIEF
R3246/R2632	3200 psi (220 bar)	2550 psi (176 bar)	1150 psi (80 bar)

1.6 HYDRAULIC CYLINDER SPECIFICATIONS

DESCRIPTION	R3246	R2632
Lift Cylinder Bore Diameter	3.94 in. (100 mm)	3.54 in. (80 mm)
Lift Cylinder Stroke	47.85 in. (1215.5 mm)	47.6 in. (1210.5 mm)
Lift Cylinder Rod Diameter	2.56 in. (65 mm)	2.36 in. (60 mm)
Steer Cylinder Bore Diameter	2.36 in. (60 mm)	
Steer Cylinder Stroke (total)	5.75 in. (146 mm)	6.2 in. (160 mm)
Steer Cylinder Rod Diameter	1.38 in. (35 mm)	

1.7 SERIAL NUMBER LOCATION

For machine identification, a serial number plate is affixed to the machine.

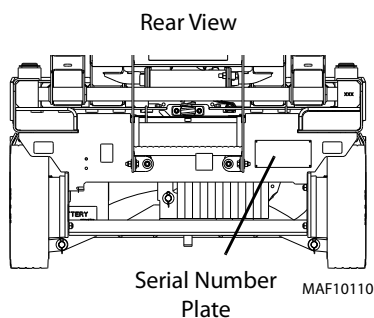

1.8 CRITICAL STABILITY WEIGHTS

⚠ WARNING

DO NOT REPLACE ITEMS CRITICAL TO STABILITY, SUCH AS BATTERIES OR TIRES, WITH ITEMS OF DIFFERENT WEIGHT OR SPECIFICATION. DO NOT MODIFY THE MEWP IN ANY WAY TO AFFECT STABILITY.

COMPONENT	R3246	R2632
Wheel and Tire Assembly (each)	52.7 lb (23.9 kg)	
Wheel/Tire and Drive Assembly (each)	83 lb (37.6 kg)	81.1 lb (36.8 kg)
Wheel/Tire and Brake Assembly (each)	90 lb (40.8 kg)	89.7 lb (40.7 kg)
Batteries (each)		
Standard:	63 lb (28.6 kg)	
AGM:	66 lb (30 kg)	
Extended Range:	75 lb (34 kg)	
Batteries (combined X4)		
Standard:	252 lb (114 kg)	
AGM:	265 lb (120 kg)	
Extended Range:	300 lb (136 kg)	

1.9 MAJOR COMPONENT WEIGHTS

COMPONENT	R3246		R2632
	(ANSI/CSA/ KOR/JPN/CE/ GB)	(AUS)	ALL MARKETS
Platform with Rails/Extension (Rail in Rail)	474 lb (215 Kg)	474 lb (215 Kg)	388 lb (176 Kg)
Platform with Rails/Extension (Dual Rail)	494 lb (224 Kg)	494 lb (224 Kg)	409 lb (186 Kg)
Arm Assembly - (Including Lift Cylinder)	1984 lb (900 Kg)	1984 lb (900 Kg)	1142 lb (518 Kg)
Chassis w/Wheels/Tires/ Steering/PHP and Drive Assemblies	2951 lb (1339 Kg)	3051 lb (1384 Kg)	2750 lb (1247 Kg)

1.10 TORQUE REQUIREMENTS

Self-locking fasteners, such as nylon insert and thread deforming locknuts, are not intended to be reinstalled after removal. Always use new replacement hardware when installing locking fasteners.

NOTE: *When maintenance becomes necessary or a fastener has loosened, refer to the Thread Locking Compound on page 1-10 to determine proper torque value.*

SECTION 1 - SPECIFICATIONS

1.11 THREAD LOCKING COMPOUND

JLG PN	Loctite®	ND Industries	Description
0100011	242™	Vibra-TITE™121	Medium Strength (Blue)
1001095650	243™	Vibra-TITE™122	Medium Strength (Blue)
0100019	271™	Vibra-TITE™140	High Strength (Red)
0100071	262™	Vibra-TITE™131	Medium - High Strength (Red)

NOTE: Loctite® 243™ can be substituted in place of Loctite® 242™. Vibra-TITE™ 122 can be substituted in place of Vibra-TITE™ 121.

1.12 TORQUE CHARTS

SAE Fastener Torque Chart

Values for Zinc Yellow Chromate Fasteners (Ref 4150707)												
SAE GRADE 5 BOLTS & GRADE 2 NUTS												
Size	TPI	Bolt Dia	Tensile Stress Area	Clamp Load	Torque (Dry)		Torque Lubricated		Torque (Loctite® 242™ or 271™ or Vibra-TITE™ 111 or 140)		Torque (Loctite® 262™ or Vibra-TITE™ 131)	
					IN-LB	[N.m]	IN-LB	[N.m]	IN-LB	[N.m]	IN-LB	[N.m]
4	40	0.1120	0.00604	380	8	0.9	6	0.7				
	48	0.1120	0.00661	420	9	1.0	7	0.8				
6	32	0.1380	0.00909	580	16	1.8	12	1.4				
	40	0.1380	0.01015	610	18	2.0	13	1.5				
8	32	0.1640	0.01400	900	30	3.4	22	2.5				
	36	0.1640	0.01474	940	31	3.5	23	2.6				
10	24	0.1900	0.01750	1120	43	4.8	32	3.5				
	32	0.1900	0.02000	1285	49	5.5	36	4				
1/4	20	0.2500	0.0318	2020	96	10.8	75	9	105	12		
	28	0.2500	0.0364	2320	120	13.5	86	10	135	15		
		In	Sq In	LB	FT-LB	[N.m]	FT-LB	[N.m]	FT-LB	[N.m]	FT-LB	[N.m]
5/16	18	0.3125	0.0524	3340	17	23	13	18	19	26	16	22
	24	0.3125	0.0580	3700	19	26	14	19	21	29	17	23
3/8	16	0.3750	0.0775	4940	30	41	23	31	35	48	28	38
	24	0.3750	0.0878	5600	35	47	25	34	40	54	32	43
7/16	14	0.4375	0.1063	6800	50	68	35	47	55	75	45	61
	20	0.4375	0.1187	7550	55	75	40	54	60	82	50	68
1/2	13	0.5000	0.1419	9050	75	102	55	75	85	116	68	92
	20	0.5000	0.1599	10700	90	122	65	88	100	136	80	108
9/16	12	0.5625	0.1820	11600	110	149	80	108	120	163	98	133
	18	0.5625	0.2030	12950	120	163	90	122	135	184	109	148
5/8	11	0.6250	0.2260	14400	150	203	110	149	165	224	135	183
	18	0.6250	0.2560	16300	170	230	130	176	190	258	153	207
3/4	10	0.7500	0.3340	21300	260	353	200	271	285	388	240	325
	16	0.7500	0.3730	23800	300	407	220	298	330	449	268	363
7/8	9	0.8750	0.4620	29400	430	583	320	434	475	646	386	523
	14	0.8750	0.5090	32400	470	637	350	475	520	707	425	576
1	8	1.0000	0.6060	38600	640	868	480	651	675	918	579	785
	12	1.0000	0.6630	42200	700	949	530	719	735	1000	633	858
1 1/8	7	1.1250	0.7630	42300	800	1085	600	813	840	1142	714	968
	12	1.1250	0.8560	47500	880	1193	660	895	925	1258	802	1087
1 1/4	7	1.2500	0.9690	53800	1120	1518	840	1139	1175	1598	1009	1368
	12	1.2500	1.0730	59600	1240	1681	920	1247	1300	1768	1118	1516
1 3/8	6	1.3750	1.1550	64100	1460	1979	1100	1491	1525	2074	1322	1792
	12	1.3750	1.3150	73000	1680	2278	1260	1708	1750	2380	1506	2042
1 1/2	6	1.5000	1.4050	78000	1940	2630	1460	1979	2025	2754	1755	2379
	12	1.5000	1.5800	87700	2200	2983	1640	2224	2300	3128	1974	2676

NOTES: 1. THESE TORQUE VALUES DO NOT APPLY TO CADMIUM PLATED FASTENERS

5000059K

2. ALL TORQUE VALUES ARE STATIC TORQUE MEASURED PER STANDARD AUDIT METHODS TOLERANCE = ±10%

3. * ASSEMBLY USES HARDENED WASHER

SECTION 1 - SPECIFICATIONS

SAE Fastener Torque Chart (Continued)

Values for Zinc Yellow Chromate Fasteners (Ref 4150707)										
SAE GRADE 8 (HEX HD) BOLTS & GRADE 8 NUTS*										
Size	TPI	Bolt Dia	Tensile Stress Area	Clamp Load	Torque (Dry or Loctite® 263) K=0.20		Torque (Loctite® 242™ or 271™ or Vibra-TITE™ 111 or 140) K=0.18		Torque (Loctite® 262™ or Vibra-TITE™ 131) K=0.15	
					IN-LB	[N.m]	IN-LB	[N.m]	IN-LB	[N.m]
4	40	0.1120	0.00604							
	48	0.1120	0.00661							
6	32	0.1380	0.00909							
	40	0.1380	0.01015							
8	32	0.1640	0.01400							
	36	0.1640	0.01474	1320	43	5				
10	24	0.1900	0.01750	1580	60	7				
	32	0.1900	0.02000	1800	68	8				
1/4	20	0.2500	0.0318	2860	143	16	129	15		
	28	0.2500	0.0364	3280	164	19	148	17		
		In	Sq In	LB	FT-LB	[N.m]	FT-LB	[N.m]	FT-LB	[N.m]
5/16	18	0.3125	0.0524	4720	25	35	20	25	20	25
	24	0.3125	0.0580	5220	25	35	25	35	20	25
3/8	16	0.3750	0.0775	7000	45	60	40	55	35	50
	24	0.3750	0.0878	7900	50	70	45	60	35	50
7/16	14	0.4375	0.1063	9550	70	95	65	90	50	70
	20	0.4375	0.1187	10700	80	110	70	95	60	80
1/2	13	0.5000	0.1419	12750	105	145	95	130	80	110
	20	0.5000	0.1599	14400	120	165	110	150	90	120
9/16	12	0.5625	0.1820	16400	155	210	140	190	115	155
	18	0.5625	0.2030	18250	170	230	155	210	130	175
5/8	11	0.6250	0.2260	20350	210	285	190	260	160	220
	18	0.6250	0.2560	23000	240	325	215	290	180	245
3/4	10	0.7500	0.3340	30100	375	510	340	460	280	380
	16	0.7500	0.3730	33600	420	570	380	515	315	430
7/8	9	0.8750	0.4620	41600	605	825	545	740	455	620
	14	0.8750	0.5090	45800	670	910	600	815	500	680
1	8	1.0000	0.6060	51500	860	1170	770	1045	645	875
	12	1.0000	0.6630	59700	995	1355	895	1215	745	1015
1 1/8	7	1.1250	0.7630	68700	1290	1755	1160	1580	965	1310
	12	1.1250	0.8560	77000	1445	1965	1300	1770	1085	1475
1 1/4	7	1.2500	0.9690	87200	1815	2470	1635	2225	1365	1855
	12	1.2500	1.0730	96600	2015	2740	1810	2460	1510	2055
1 3/8	6	1.3750	1.1550	104000	2385	3245	2145	2915	1785	2430
	12	1.3750	1.3150	118100	2705	3680	2435	3310	2030	2760
1 1/2	6	1.5000	1.4050	126500	3165	4305	2845	3870	2370	3225
	12	1.5000	1.5800	142200	3555	4835	3200	4350	2665	3625

- NOTES: 1. THESE TORQUE VALUES DO NOT APPLY TO CADMIUM PLATED FASTENERS
 2. ALL TORQUE VALUES ARE STATIC TORQUE MEASURED PER STANDARD AUDIT METHODS TOLERANCE = ±10%
 3. * ASSEMBLY USES HARDENED WASHER

5000059K

SAE Fastener Torque Chart (Continued)

Values for Magni Coating Fasteners (Ref 4150701)										
SAE GRADE 5 BOLTS & GRADE 2 NUTS										
Size	TPI	Bolt Dia	Tensile Stress Area	Clamp Load	Torque (Dry) K=0.17		Torque (Loctite® 242™ or 271™ or Vibra-TITE™ 111 or 140) K=0.16		Torque (Loctite® 262™ or Vibra-TITE™ 131) K=0.15	
					IN-LB	[N.m]	IN-LB	[N.m]	IN-LB	[N.m]
		In	Sq In	LB	IN-LB	[N.m]	IN-LB	[N.m]	IN-LB	[N.m]
4	40	0.1120	0.00604	380	7	0.8				
	48	0.1120	0.00661	420	8	0.9				
6	32	0.1380	0.00909	580	14	1.5				
	40	0.1380	0.01015	610	14	1.6				
8	32	0.1640	0.01400	900	25	2.8				
	36	0.1640	0.01474	940	26	2.9				
10	24	0.1900	0.01750	1120	36	4.1				
	32	0.1900	0.02000	1285	42	4.7				
1/4	20	0.2500	0.0318	2020	86	9.7	80	9		
	28	0.2500	0.0364	2320	99	11.1	95	11		
		In	Sq In	LB	FT-LB	[N.m]	FT-LB	[N.m]	FT-LB	[N.m]
5/16	18	0.3125	0.0524	3340	15	20	14	19	15	20
	24	0.3125	0.0580	3700	15	20	15	21	15	20
3/8	16	0.3750	0.0775	4940	25	35	25	34	25	34
	24	0.3750	0.0878	5600	30	40	28	38	25	34
7/16	14	0.4375	0.1063	6800	40	55	40	54	35	48
	20	0.4375	0.1187	7550	45	60	44	60	40	54
1/2	13	0.5000	0.1419	9050	65	90	60	82	55	75
	20	0.5000	0.1599	10700	75	100	71	97	65	88
9/16	12	0.5625	0.1820	11600	90	120	87	118	80	109
	18	0.5625	0.2030	12950	105	145	97	132	90	122
5/8	11	0.6250	0.2260	14400	130	175	120	163	115	156
	18	0.6250	0.2560	16300	145	195	136	185	125	170
3/4	10	0.7500	0.3340	21300	225	305	213	290	200	272
	16	0.7500	0.3730	23800	255	345	238	324	225	306
7/8	9	0.8750	0.4620	29400	365	495	343	466	320	435
	14	0.8750	0.5090	32400	400	545	378	514	355	483
1	8	1.0000	0.6060	38600	545	740	515	700	480	653
	12	1.0000	0.6630	42200	600	815	563	765	530	721
1 1/8	7	1.1250	0.7630	42300	675	920	635	863	595	809
	12	1.1250	0.8560	47500	755	1025	713	969	670	911
1 1/4	7	1.2500	0.9690	53800	955	1300	897	1219	840	1142
	12	1.2500	1.0730	59600	1055	1435	993	1351	930	1265
1 3/8	6	1.3750	1.1550	64100	1250	1700	1175	1598	1100	1496
	12	1.3750	1.3150	73000	1420	1930	1338	1820	1255	1707
1 1/2	6	1.5000	1.4050	78000	1660	2260	1560	2122	1465	1992
	12	1.5000	1.5800	87700	1865	2535	1754	2385	1645	2237

- NOTES: 1. THESE TORQUE VALUES DO NOT APPLY TO CADMIUM PLATED FASTENERS
2. ALL TORQUE VALUES ARE STATIC TORQUE MEASURED PER STANDARD AUDIT METHODS TOLERANCE = ±10%
3. * ASSEMBLY USES HARDENED WASHER

5000059K

SECTION 1 - SPECIFICATIONS

SAE Fastener Torque Chart (Continued)

Values for Magni Coating Fasteners (Ref 4150701)										
SAE GRADE 8 (HEX HD) BOLTS & GRADE 8 NUTS*										
Size	TPI	Bolt Dia	Tensile Stress Area	Clamp Load	Torque (Dry or Loctite® 263) K=0.17		Torque (Loctite® 242™ or 271™ or Vibra-TITE™ 111 or 140) K=0.16		Torque (Loctite® 262™ or Vibra-TITE™ 131) K=0.15	
					IN-LB	[N.m]	IN-LB	[N.m]	IN-LB	[N.m]
		In	Sq In	LB	IN-LB	[N.m]	IN-LB	[N.m]	IN-LB	[N.m]
4	40	0.1120	0.00604							
	48	0.1120	0.00661							
6	32	0.1380	0.00909							
	40	0.1380	0.01015							
8	32	0.1640	0.01400							
	36	0.1640	0.01474	1320	37	4				
10	24	0.1900	0.01750	1580	51	6				
	32	0.1900	0.02000	1800	58	7				
1/4	20	0.2500	0.0318	2860	122	14	114	13		
	28	0.2500	0.0364	3280	139	16	131	15		
		In	Sq In	LB	FT-LB	[N.m]	FT-LB	[N.m]	FT-LB	[N.m]
5/16	18	0.3125	0.0524	4720	20	25	20	25	20	25
	24	0.3125	0.0580	5220	25	35	20	25	20	25
3/8	16	0.3750	0.0775	7000	35	50	35	50	35	50
	24	0.3750	0.0878	7900	40	55	40	55	35	50
7/16	14	0.4375	0.1063	9550	60	80	55	75	50	70
	20	0.4375	0.1187	10700	65	90	60	80	60	80
1/2	13	0.5000	0.1419	12750	90	120	85	115	80	110
	20	0.5000	0.1599	14400	100	135	95	130	90	120
9/16	12	0.5625	0.1820	16400	130	175	125	170	115	155
	18	0.5625	0.2030	18250	145	195	135	185	130	175
5/8	11	0.6250	0.2260	20350	180	245	170	230	160	220
	18	0.6250	0.2560	23000	205	280	190	260	180	245
3/4	10	0.7500	0.3340	30100	320	435	300	410	280	380
	16	0.7500	0.3730	33600	355	485	335	455	315	430
7/8	9	0.8750	0.4620	41600	515	700	485	660	455	620
	14	0.8750	0.5090	45800	570	775	535	730	500	680
1	8	1.0000	0.6060	51500	730	995	685	930	645	875
	12	1.0000	0.6630	59700	845	1150	795	1080	745	1015
1 1/8	7	1.1250	0.7630	68700	1095	1490	1030	1400	965	1310
	12	1.1250	0.8560	77000	1225	1665	1155	1570	1085	1475
1 1/4	7	1.2500	0.9690	87200	1545	2100	1455	1980	1365	1855
	12	1.2500	1.0730	96600	1710	2325	1610	2190	1510	2055
1 3/8	6	1.3750	1.1550	104000	2025	2755	1905	2590	1785	2430
	12	1.3750	1.3150	118100	2300	3130	2165	2945	2030	2760
1 1/2	6	1.5000	1.4050	126500	2690	3660	2530	3440	2370	3225
	12	1.5000	1.5800	142200	3020	4105	2845	3870	2665	3625

- NOTES: 1. THESE TORQUE VALUES DO NOT APPLY TO CADMIUM PLATED FASTENERS 5000059K
 2. ALL TORQUE VALUES ARE STATIC TORQUE MEASURED PER STANDARD AUDIT METHOD TOLERANCE = ±10%
 3. * ASSEMBLY USES HARDENED WASHER

SAE Fastener Torque Chart (Continued)

Values for Magni Coating Fasteners (Ref 4150701)										
SOCKET HEAD CAPSCREWS										
Size	TPI	Bolt Dia	Tensile Stress Area	Clamp Load See Note 4	Torque (Dry) K=0.17		Torque (Loctite® 242™ or 271™ or Vibra-TITE™ 111 or 140) or Precoat® 85 K=0.16		Torque (Loctite® 262™ or Vibra-TITE™ 131) K=0.15	
					IN-LB	[N.m]	IN-LB	[N.m]	IN-LB	[N.m]
		In	Sq In	LB	IN-LB	[N.m]	IN-LB	[N.m]	IN-LB	[N.m]
4	40	0.1120	0.00604							
	48	0.1120	0.00661							
6	32	0.1380	0.00909							
	40	0.1380	0.01015							
8	32	0.1640	0.01400							
	36	0.1640	0.01474							
10	24	0.1900	0.01750							
	32	0.1900	0.02000							
1/4	20	0.2500	0.0318	2860	122	14	114	13		
	28	0.2500	0.0364	3280	139	16	131	15		
		In	Sq In	LB	FT-LB	[N.m]	FT-LB	[N.m]	FT-LB	[N.m]
5/16	18	0.3125	0.0524	4720	20	25	20	25	20	25
	24	0.3125	0.0580	5220	25	35	20	25	20	25
3/8	16	0.3750	0.0775	7000	35	50	35	50	35	50
	24	0.3750	0.0878	7900	40	55	40	55	35	50
7/16	14	0.4375	0.1063	9550	60	80	55	75	50	70
	20	0.4375	0.1187	10700	65	90	60	80	60	80
1/2	13	0.5000	0.1419	12750	90	120	85	115	80	110
	20	0.5000	0.1599	14400	100	135	95	130	90	120
9/16	12	0.5625	0.1820	16400	130	175	125	170	115	155
	18	0.5625	0.2030	18250	145	195	135	185	130	175
5/8	11	0.6250	0.2260	20350	180	245	170	230	160	220
	18	0.6250	0.2560	23000	205	280	190	260	180	245
3/4	10	0.7500	0.3340	30100	320	435	300	415	280	380
	16	0.7500	0.3730	33600	355	485	335	455	315	430
7/8	9	0.8750	0.4620	41600	515	700	485	660	455	620
	14	0.8750	0.5090	45800	570	775	535	730	500	680
1	8	1.0000	0.6060	51500	730	995	685	930	645	875
	12	1.0000	0.6630	59700	845	1150	795	1080	745	1015
1 1/8	7	1.1250	0.7630	68700	1095	1490	1030	1400	965	1310
	12	1.1250	0.8560	77000	1225	1665	1155	1570	1085	1475
1 1/4	7	1.2500	0.9690	87200	1545	2100	1455	1980	1365	1855
	12	1.2500	1.0730	96600	1710	2325	1610	2190	1510	2055
1 3/8	6	1.3750	1.1550	104000	2025	2755	1905	2590	1785	2430
	12	1.3750	1.3150	118100	2300	3130	2165	2945	2030	2760
1 1/2	6	1.5000	1.4050	126500	2690	3660	2530	3440	2370	3225
	12	1.5000	1.5800	142200	3020	4105	2845	3870	2665	3625

- NOTES: 1. THESE TORQUE VALUES DO NOT APPLY TO CADMIUM PLATED FASTENERS
2. ALL TORQUE VALUES ARE STATIC TORQUE MEASURED PER STANDARD AUDIT METHODS TOLERANCE = ±10%
3. * ASSEMBLY USES HARDENED WASHER
4. CLAMP LOAD LISTED FOR SHCS IS SAME AS GRADE 8 OR CLASS 10.9 AND DOES NOT REPRESENT FULL STRENGTH CAPABILITY OF SHCS. IF HIGHER LOAD IS REQUIRED, ADDITIONAL TESTING IS REQUIRED.

5000059K

SECTION 1 - SPECIFICATIONS

SAE Fastener Torque Chart (Continued)

Values for Zinc Yellow Chromate Fasteners (Ref 4150707)*										
SOCKET HEAD CAPSCREWS										
Size	TPI	Bolt Dia	Tensile Stress Area	Clamp Load See Note 4	Torque (Dry) K=0.17		Torque (Loctite® 242™ or 271™ or Vibra-TITE™ 111 or 140) or Precoat® 85 K=0.16		Torque (Loctite® 262™ or Vibra-TITE™ 131) K=0.15	
					IN-LB	[N.m]	IN-LB	[N.m]	IN-LB	[N.m]
		In	Sq In	LB						
4	40	0.1120	0.00604							
	48	0.1120	0.00661							
6	32	0.1380	0.00909							
	40	0.1380	0.01015							
8	32	0.1640	0.01400							
	36	0.1640	0.01474							
10	24	0.1900	0.01750							
	32	0.1900	0.02000							
1/4	20	0.2500	0.0318	2860	122	14	114	13		
	28	0.2500	0.0364	3280	139	16	131	15		
		In	Sq In	LB	FT-LB	[N.m]	FT-LB	[N.m]	FT-LB	[N.m]
5/16	18	0.3125	0.0524	4720	20	25	20	25	20	25
	24	0.3125	0.0580	5220	25	35	20	25	20	25
3/8	16	0.3750	0.0775	7000	35	50	35	50	35	50
	24	0.3750	0.0878	7900	40	55	40	55	35	50
7/16	14	0.4375	0.1063	9550	60	80	55	75	50	70
	20	0.4375	0.1187	10700	65	90	60	80	60	80
1/2	13	0.5000	0.1419	12750	90	120	85	115	80	110
	20	0.5000	0.1599	14400	100	135	95	130	90	120
9/16	12	0.5625	0.1820	16400	130	175	125	170	115	155
	18	0.5625	0.2030	18250	145	195	135	185	130	175
5/8	11	0.6250	0.2260	20350	180	245	170	230	160	220
	18	0.6250	0.2560	23000	205	280	190	260	180	245
3/4	10	0.7500	0.3340	30100	320	435	300	415	280	380
	16	0.7500	0.3730	33600	355	485	335	455	315	430
7/8	9	0.8750	0.4620	41600	515	700	485	660	455	620
	14	0.8750	0.5090	45800	570	775	535	730	500	680
1	8	1.0000	0.6060	51500	730	995	685	930	645	875
	12	1.0000	0.6630	59700	845	1150	795	1080	745	1015
1 1/8	7	1.1250	0.7630	68700	1095	1490	1030	1400	965	1310
	12	1.1250	0.8560	77000	1225	1665	1155	1570	1085	1475
1 1/4	7	1.2500	0.9690	87200	1545	2100	1455	1980	1365	1855
	12	1.2500	1.0730	96600	1710	2325	1610	2190	1510	2055
1 3/8	6	1.3750	1.1550	104000	2025	2755	1905	2590	1785	2430
	12	1.3750	1.3150	118100	2300	3130	2165	2945	2030	2760
1 1/2	6	1.5000	1.4050	126500	2690	3660	2530	3440	2370	3225
	12	1.5000	1.5800	142200	3020	4105	2845	3870	2665	3625

- NOTES: 1. THESE TORQUE VALUES DO NOT APPLY TO CADMIUM PLATED FASTENERS 5000059K
 2. ALL TORQUE VALUES ARE STATIC TORQUE MEASURED PER STANDARD AUDIT METHODS TOLERANCE = ±10%
 3. * ASSEMBLY USES HARDENED WASHER
 4. CLAMP LOAD LISTED FOR SHCS IS SAME AS GRADE 8 OR CLASS 10.9 AND DOES NOT REPRESENT FULL STRENGTH CAPABILITY OF SHCS. IF HIGHER LOAD IS REQUIRED, ADDITIONAL TESTING IS REQUIRED.

Metric Fastener Torque Chart

Values for Zinc Yellow Chromate Fasteners (Ref 4150707)*							
CLASS 8.8 METRIC (HEX/SOCKET HEAD) BOLTS CLASS 8 METRIC NUTS							
Size	Pitch	Tensile Stress Area	Clamp Load See Note 4	Torque (Dry or Loctite® 263™)	Torque (Lube)	Torque (Loctite® 262™ or 271™ or Vibra-TITE™ 131)	Torque (Loctite® 242™ or 271™ or Vibra-TITE™ 111 or 141)
		Sq mm	KN	[N.m]		[N.m]	[N.m]
3	0.5	5.03	2.19	1.3	1.0	1.2	1.4
3.5	0.6	6.78	2.95	2.1	1.6	1.9	2.3
4	0.7	8.78	3.82	3.1	2.3	2.8	3.4
5	0.8	14.20	6.18	6.2	4.6	5.6	6.8
6	1	20.10	8.74	11	7.9	9.4	12
7	1	28.90	12.6	18	13	16	19
8	1.25	36.60	15.9	26	19	23	28
10	1.5	58.00	25.2	50	38	45	55
12	1.75	84.30	36.7	88	66	79	97
14	2	115	50.0	140	105	126	154
16	2	157	68.3	219	164	197	241
18	2.5	192	83.5	301	226	271	331
20	2.5	245	106.5	426	320	383	469
22	2.5	303	132.0	581	436	523	639
24	3	353	153.5	737	553	663	811
27	3	459	199.5	1080	810	970	1130
30	3.5	561	244.0	1460	1100	1320	1530
33	3.5	694	302.0	1990	1490	1790	2090
36	4	817	355.5	2560	1920	2300	2690
42	4.5	1120	487.0	4090	3070	3680	4290

- NOTES: 1. THESE TORQUE VALUES DO NOT APPLY TO CADMIUM PLATED FASTENERS
2. ALL TORQUE VALUES ARE STATIC TORQUE MEASURED PER STANDARD AUDIT METHODSTOLERANCE = ±10%
3. * ASSEMBLY USES HARDENED WASHER
4. CLAMP LOAD LISTED FOR SHCS IS SAME AS GRADE 8 OR CLASS 10.9 AND DOES NOT REPRESENT FULL STRENGTH CAPABILITY OF SHCS. IF HIGHER LOAD IS REQUIRED, ADDITIONAL TESTING IS REQUIRED.

5000059K

SECTION 1 - SPECIFICATIONS

Metric Fastener Torque Chart (Continued)

Values for Zinc Yellow Chromate Fasteners (Ref 4150707)*						
CLASS 10.9 METRIC (HEX HEAD) BOLTS, CLASS 10 METRIC NUTS CLASS 12.9 SOCKET HEAD CAPSCREWS M3 - M5*						
Size	Pitch	Tensile Stress Area	Clamp Load See Note 4	Torque (Dry or Loctite® 263™) K=0.20	Torque (Lube or Loctite® 242™ or 271™ or Vibra-TITE™ 111 or 140) K=0.18	Torque (Loctite® 262™ or Vibra-TITE™ 131) K=0.15
		Sq mm	KN	[N.m]	[N.m]	[N.m]
3	0.5	5.03	3.13			
3.5	0.6	6.78	4.22			
4	0.7	8.78	5.47			
5	0.8	14.20	8.85			
6	1	20.10	12.5			
7	1	28.90	18.0	25	23	19
8	1.25	36.60	22.8	37	33	27
10	1.5	58.00	36.1	70	65	55
12	1.75	84.30	52.5	125	115	95
14	2	115	71.6	200	180	150
16	2	157	97.8	315	280	235
18	2.5	192	119.5	430	385	325
20	2.5	245	152.5	610	550	460
22	2.5	303	189.0	830	750	625
24	3	353	222.0	1065	960	800
27	3	459	286.0	1545	1390	1160
30	3.5	561	349.5	2095	1885	1575
33	3.5	694	432.5	2855	2570	2140
36	4	817	509.0	3665	3300	2750
42	4.5	1120	698.0	5865	5275	4395

- NOTES: 1. THESE TORQUE VALUES DO NOT APPLY TO CADMIUM PLATED FASTENERS 5000059K
 2. ALL TORQUE VALUES ARE STATIC TORQUE MEASURED PER STANDARD AUDIT METHODS TOLERANCE = ±10%
 3. * ASSEMBLY USES HARDENED WASHER
 4. CLAMP LOAD LISTED FOR SHCS IS SAME AS GRADE 8 OR CLASS 10.9 AND DOES NOT REPRESENT FULL STRENGTH CAPABILITY OF SHCS. IF HIGHER LOAD IS REQUIRED, ADDITIONAL TESTING IS REQUIRED.

Metric Fastener Torque Chart (Continued)

Values for Magni Coated Fasteners (Ref 4150701)*						
CLASS 8.8 METRIC (HEX/SOCKET HEAD) BOLTS CLASS 8 METRIC NUTS						
Size	Pitch	Tensile Stress Area	Clamp Load See Note 4	Torque (Dry or Loctite® 263™) K=0.17	Torque (Lube or Loctite® 242™ or 271™ or Vibra-TITE™ 111 or 140) K=0.16	Torque (Loctite® 262™ or Vibra-TITE™ 131) K=0.15
		Sq mm	KN	[N.m]	[N.m]	[N.m]
3	0.5	5.03	2.19	1.1	1.1	1.0
3.5	0.6	6.78	2.95	1.8	1.7	1.5
4	0.7	8.78	3.82	2.6	2.4	2.3
5	0.8	14.20	6.18	5.3	4.9	4.6
6	1	20.10	8.74	9	8.4	7.9
7	1	28.90	12.6	15	14	13
8	1.25	36.60	15.9	22	20	19
10	1.5	58.00	25.2	43	40	38
12	1.75	84.30	36.7	75	70	66
14	2	115	50.0	119	110	105
16	2	157	68.3	186	175	165
18	2.5	192	83.5	256	240	225
20	2.5	245	106.5	362	340	320
22	2.5	303	132.0	494	465	435
24	3	353	153.5	627	590	555
27	3	459	199.5	916	860	810
30	3.5	561	244.0	1245	1170	1100
33	3.5	694	302.0	1694	1595	1495
36	4	817	355.5	2176	2050	1920
42	4.5	1120	487.0	3477	3275	3070

- NOTES:
1. THESE TORQUE VALUES DO NOT APPLY TO CADMIUM PLATED FASTENERS
 2. ALL TORQUE VALUES ARE STATIC TORQUE MEASURED PER STANDARD AUDIT METHODS TOLERANCE = $\pm 10\%$
 3. * ASSEMBLY USES HARDENED WASHER
 4. CLAMP LOAD LISTED FOR SHCS IS SAME AS GRADE 8 OR CLASS 10.9 AND DOES NOT REPRESENT FULL STRENGTH CAPABILITY OF SHCS. IF HIGHER LOAD IS REQUIRED, ADDITIONAL TESTING IS REQUIRED.

5000059K

SECTION 1 - SPECIFICATIONS

Metric Fastener Torque Chart (Continued)

Values for Magni Coated Fasteners (Ref 4150701)*						
CLASS 10.9 METRIC (HEX HEAD) BOLTS CLASS 10 METRIC NUTS, CLASS 12.9 SOCKET HEAD CAPSCREWS M6 AND ABOVE*						
Size	Pitch	Tensile Stress Area	Clamp Load See Note 4	Torque (Dry or Loctite® 263™) K=0.17	Torque (Lube or Loctite® 242™ or 271™ or Vibra-TITE™ 111 or 140) K=0.18	Torque (Loctite® 262™ or Vibra-TITE™ 131) K=0.15
		Sq mm	KN	[N.m]	[N.m]	[N.m]
3	0.5	5.03	3.13			
3.5	0.6	6.78	4.22			
4	0.7	8.78	5.47			
5	0.8	14.20	8.85			
6	1	20.10	12.5	13	12	11
7	1	28.90	18.0	21	20	19
8	1.25	36.60	22.8	31	29	27
10	1.5	58.00	36.1	61	58	55
12	1.75	84.30	52.5	105	100	95
14	2	115	71.6	170	160	150
16	2	157	97.8	265	250	235
18	2.5	192	119.5	365	345	325
20	2.5	245	152.5	520	490	460
22	2.5	303	189.0	705	665	625
24	3	353	222.0	905	850	800
27	3	459	286.0	1315	1235	1160
30	3.5	561	349.5	1780	1680	1575
33	3.5	694	432.5	2425	2285	2140
36	4	817	509.0	3115	2930	2750
42	4.5	1120	698.0	4985	4690	4395

- NOTES: 1. THESE TORQUE VALUES DO NOT APPLY TO CADMIUM PLATED FASTENERS 5000059K
 2. ALL TORQUE VALUES ARE STATIC TORQUE MEASURED PER STANDARD AUDIT METHODS TOLERANCE = ±10%
 3. * ASSEMBLY USES HARDENED WASHER
 4. CLAMP LOAD LISTED FOR SHCS IS SAME AS GRADE 8 OR CLASS 10.9 AND DOES NOT REPRESENT FULL STRENGTH CAPABILITY OF SHCS. IF HIGHER LOAD IS REQUIRED, ADDITIONAL TESTING IS REQUIRED.

SECTION 2. GENERAL

2.1 MACHINE PREPARATION, INSPECTION, AND MAINTENANCE

General

This section provides the necessary information needed by those personnel that are responsible to place the machine in operation readiness and maintain its safe operating condition. For maximum service life and safe operation, ensure that all the necessary inspections and maintenance have been completed before placing the machine into service. With proper care, maintenance and inspections performed per JLG's recommendations with any and all discrepancies corrected, this product will be fit for continued use.

Preparation, Inspection, and Maintenance

It is important to establish and conform to a comprehensive inspection and preventive maintenance program. The following table outlines the periodic machine inspections and maintenance recommended by JLG Industries, Inc. Consult your national, regional, or local regulations for further requirements for Mobile Elevating Work Platform (MEWP). The frequency of inspections and maintenance must be increased as environment, severity and frequency of usage requires.

Pre-Start Inspection

It is the User's or Operator's primary responsibility to perform a Pre-Start Inspection of the machine prior to use daily or at each change of operator. Reference the Operation and Safety Manual for completion procedures for the Pre-Start Inspection. The Operation and Safety Manual must be read in its entirety and understood prior to performing the Pre-Start Inspection.

Pre-Delivery Inspection and Frequent Inspection

The Pre-Delivery Inspection and Frequent Inspection shall be performed by a qualified JLG equipment mechanic. JLG Industries, Inc. recognizes a qualified JLG equipment mechanic as a person who, by possession of a recognized degree, certificate, extensive knowledge, training, or experience, has successfully demonstrated the ability and proficiency to service, repair, and maintain the subject JLG product model.

The Pre-Delivery Inspection and Frequent Inspection procedures are performed in the same manner, but at different times. The Pre-Delivery Inspection shall be performed prior to each sale, lease, or rental delivery. The Frequent Inspection shall be accomplished for each machine in service for 3 months or 150 hours (whichever comes first); out of service for a period of more than 3 months; or when purchased used. The frequency of this inspection must be increased as environment, severity and frequency of usage requires.

Reference the JLG Pre-Delivery and Frequent Inspection Form and the Inspection and Preventative Maintenance Schedule for items requiring inspection during the performance of these inspections. Reference the appropriate areas of this manual for servicing and maintenance procedures.

Annual Machine Inspection

JLG recommends that the Annual Machine Inspection be performed by a Factory-Trained Service Technician on an annual basis, no later than thirteen (13) months from the date of the prior Annual Machine Inspection. JLG Industries, Inc. recognizes a Factory-Trained Service Technician as a person who has successfully completed the JLG Service Training School for the subject JLG product model. Reference the machine Service and Maintenance Manual and appropriate JLG inspection form for performance of this inspection.

Reference the JLG Annual Machine Inspection Form and the Inspection and Preventative Maintenance Schedule for items requiring inspection during the performance of this inspection. Reference the appropriate areas of this manual for servicing and maintenance procedures.

For the purpose of receiving safety-related bulletins, it is important that JLG Industries, Inc. has updated ownership information for each machine. When performing each Annual Machine Inspection, notify JLG Industries, Inc. of the current machine ownership.

Preventative Maintenance

In conjunction with the specified inspections, maintenance shall be performed by a qualified JLG equipment mechanic. JLG Industries, Inc. recognizes a qualified JLG equipment mechanic as a person who, by possession of a recognized degree, certificate, extensive knowledge, training, or experience, has successfully demonstrated the ability and proficiency to service, repair, and maintain the subject JLG product model.

Reference the Preventative Maintenance Schedule and the appropriate areas of this manual for servicing and maintenance procedures. The frequency of service and maintenance must be increased as environment, severity and frequency of usage requires.

SECTION 2 - GENERAL

Table 2-1. Inspection and Maintenance Responsibilities

TYPE	FREQUENCY	PRIMARY RESPONSIBILITY	SERVICE QUALIFICATION	REFERENCE
Pre-Start Inspection	Prior to use each day; or At each Operator change.	User or Operator	User or Operator	Operation and Safety Manual
Pre-Delivery Inspection	Prior to each sale, lease, or rental delivery.	Owner, Dealer, or User	Qualified JLG Mechanic	Service and Maintenance Manual and applicable JLG inspection form.
Frequent Inspection	In service for 3 months or 150 hours, whichever comes first; or Out of service for a period of more than 3 months; or Purchased used.	Owner, Dealer, or User	Qualified JLG Mechanic	Service and Maintenance Manual and applicable JLG inspection form.
Annual Machine Inspection	Annually, no later than 13 months from the date of the prior inspection.	Owner, Dealer, or User	Factory-Trained Service Technician (recommended)	Service and Maintenance Manual and applicable JLG inspection form.
Preventative Maintenance	At intervals as specified in the Service and Maintenance Manual.	Owner, Dealer, or User	Qualified JLG Mechanic	Service and Maintenance Manual
NOTE: Inspection forms are available from JLG. Use the Service and Maintenance Manual to perform inspections.				

NOTICE

JLG INDUSTRIES, INC. RECOGNIZES A FACTORY-TRAINED SERVICE TECHNICIAN AS A PERSON WHO HAS SUCCESSFULLY COMPLETED THE JLG SERVICE TRAINING SCHOOL FOR THE SPECIFIC JLG PRODUCT MODEL.

2.2 PREVENTIVE MAINTENANCE AND INSPECTION SCHEDULE

The preventive maintenance and inspection checks are listed and defined in the following table. This table is divided into two basic parts, the "AREA" to be inspected and the "INTERVAL" at which the inspection is to take place. Under the "AREA" portion of the table, the various systems along with the components that make up that system are listed. The "INTERVAL" portion of the table is divided into two columns representing the various inspection time periods. The numbers listed within the interval column represent the applicable inspection code for which that component is to be checked.

The checks and services listed in this schedule are not intended to replace any local or regional regulations that may pertain to this type of equipment nor should the lists be considered as all inclusive. Variances in interval times may occur due to climate and/or conditions and depending on the location and use of the machine.

NOTICE

JLG INDUSTRIES REQUIRES THAT A COMPLETE ANNUAL INSPECTION BE PERFORMED IN ACCORDANCE WITH THE "ANNUAL MACHINE INSPECTION REPORT" FORM.

NOTE: *This machine requires periodic safety and maintenance inspections by a qualified JLG mechanic. Notify JLG dealer if inspection is overdue.*

Maintenance and Inspection Schedule Codes:

1. Check for proper and secure: installation, adjustment, or torque.
2. Visual inspection for damage: (cracks, corrosion, abrasions, distortion, excessive wear, broken welds, gouges, chafing and threads showing).
3. Proper operation.
4. Check for proper sealing, signs of leakage and fluid level.
5. Clean and free of debris.
6. Decals installed and legible.
7. Check for proper tolerances, routing, and lubrication.
8. Fully Charged.
9. Verify/Perform.
 - a. Drain, Clean
 - b. Refill/Replace
 - c. Lubricate

Table 2-2. Preventive Maintenance & Inspection Schedule

AREA ON MACHINE	INSPECTIONS	
	PRE-DELIVERY ⁽¹⁾ OR FREQUENT ⁽²⁾ INSPECTION	ANNUAL ⁽³⁾ (YEARLY) INSPECTION
Scissor Arms		
Scissor Arms	1,2	1,2
Safety Prop	1,2	1,2
Nuts, Bolts, Shafts, Shields, Bearings, and Locking Devices	1,2	1,2
Cylinder/Pivot Pins and Attaching Hardware	1,2	1,2
Arm Pads and Sliding Block	1,2	1,2
Platform Assembly		
Platform	1	1
Platform Gate Assembly	1,3	1,3
Extension Deck and Locks	1,3	1,3
Guard Rails and Floor	1,2	1,2
Platform Roll Pins and Fold Down Rails	1,2	1,2
Lanyard Anchorage Points	1,2,6	1,2,6
Chassis Assembly		
Wheel Rim Nuts	1 ⁵⁰	1 ⁵⁰
Tires	1	1,2
Steer and Drive Components	1	1,2,5
Side-Compartment Door Installation	1,3,5	1,3,5
Drive Motor	1	1,4,5
Platform Ladder	1,5	1,5
Drive Brakes	1	1,5
Drive Hubs	1	1,4,5
Sliding Wear Pads**	1,2,5,7	1,2,5,7
Front Wheel Spindle Nuts/Bolts	1 ⁵⁰	1 ⁵⁰

Table 2-2. Preventive Maintenance & Inspection Schedule (Continued)

AREA ON MACHINE	INSPECTIONS	
	PRE-DELIVERY ⁽¹⁾ OR FREQUENT ⁽²⁾ INSPECTION	ANNUAL ⁽³⁾ (YEARLY) INSPECTION
Functions/Controls		
Control levers, Switches, Gauges, and Instruments	1,3	1,3
Detentes, Control Enclosure, and Protective Boots/Guards	1,3	1,3
Emergency Stop Switches at Ground and Platform	1,3	1,3
Lift, Drive, and Speed Cutouts	3	3
Manual Descent Control	3	3
Function Enable System	3	3
Brakes	3	3,5
Machine Functions	3	3
Joystick/Toggle Return to Neutral/Off When Released	1,3	1,3
Load Sensing System	3	3,9
Batteries	4	4
Battery Fluid	4	4
Battery Charger	-	3
HYDRAULIC/ELECTRIC SYSTEM		
Hydraulic Cylinders	1,7	1,2,4,5,7
Pumps, Oil Lines, and Reservoir	1	1,4
Hydraulic Filter	5	5
Hydraulic Tank, Cap, Breather and Vent	1	1,4
Hydraulic Fitting	1	1,4
Electrical Connections	1,3	1,3
Switches, Gauges, Horn, and Lights	1,3	1,3
Switches and Controls	1,3	1,3
All Hydraulic Pressures	3	3
Hydraulic Fluid	8	8

Table 2-2. Preventive Maintenance & Inspection Schedule (Continued)

AREA ON MACHINE	INSPECTIONS	
	PRE-DELIVERY ⁽¹⁾ OR FREQUENT ⁽²⁾ INSPECTION	ANNUAL ⁽³⁾ (YEARLY) INSPECTION
GENERAL		
No Unauthorized Modification or Additions	9	9
Paint and Overall Appearance.	5	5
Operation and Safety Manual	9	9
General Structural Condition and Welds	2	2
Grease and Lubrication Specification	9	9
Function Test of All System	9	9
Notify JLG Change in Machine Ownership	-	9
ANSI Manual of Responsibilities and AEM Safety Manual in Storage Box (ANSI and ANSI Export Only)	9	9
Capacity Decals	9	9
All Decals/Placards	9	9
Annual Machine Inspection	-	9
Safety Publication	9	9
All Fasteners, Pins, Shields, and Covers	1,2	1,2
Footnotes: ¹ Prior to each sale, lease, or delivery. ² In service for 3 months; Out of service for 3 months or more; Purchased used. ³ Annually, no later than 13 months from the date of the prior inspection, Includes all daily and quarterly inspections, mandated by regulating body. ⁵⁰ Indicates a 50 hour interval required to perform task after initial use of machine. This only occurs once in machine life. ** Refer to Operation and Safety Manual for machine specific instructions.		

2.3 SERVICE MAINTENANCE COMPONENTS

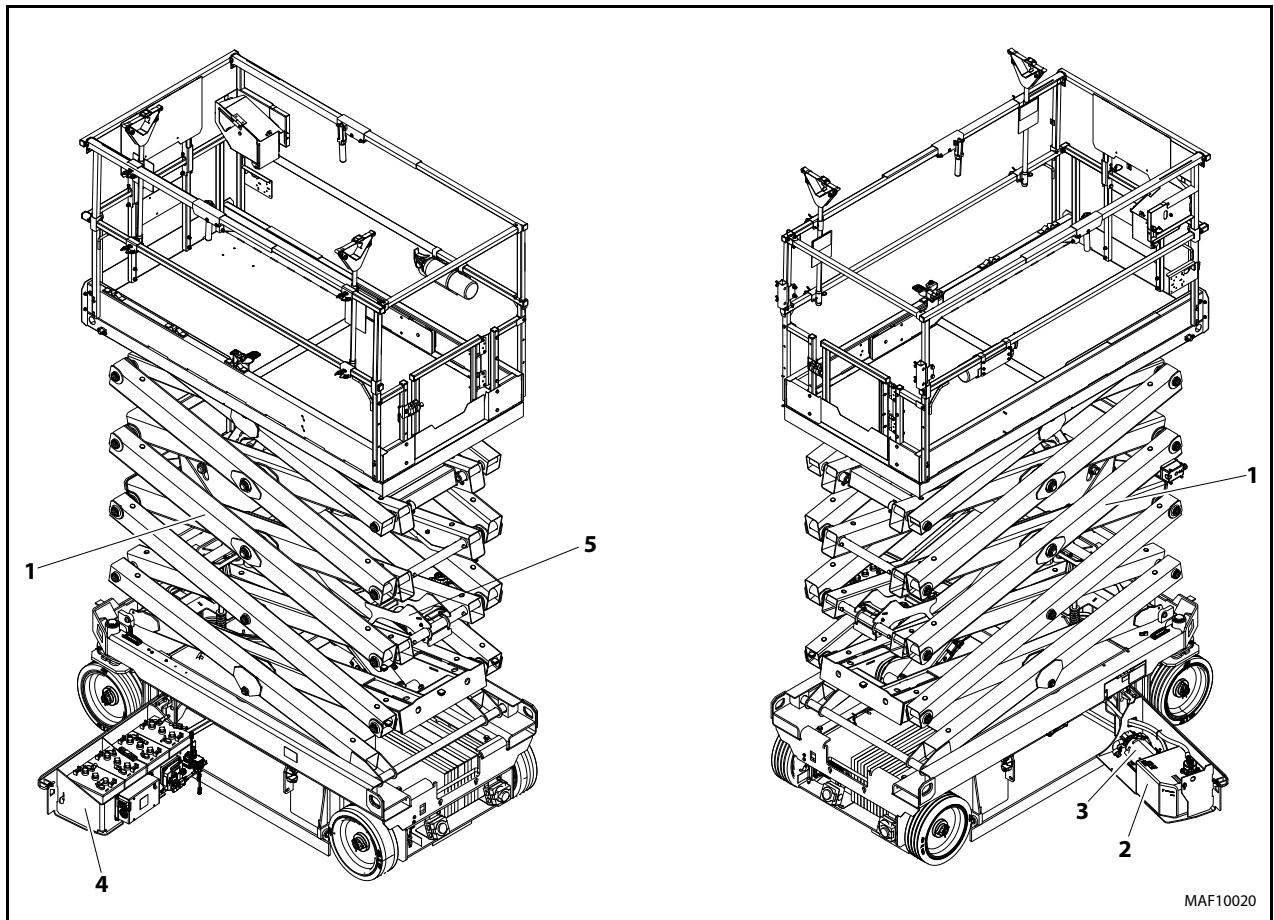

Figure 2-1. Machine Component Locations - R3246

- | | |
|-------------------|-----------------------|
| 1. Scissor Arm | 4. Batteries Location |
| 2. Hydraulic Tank | 5. Safety Prop |
| 3. Pump Assembly | |

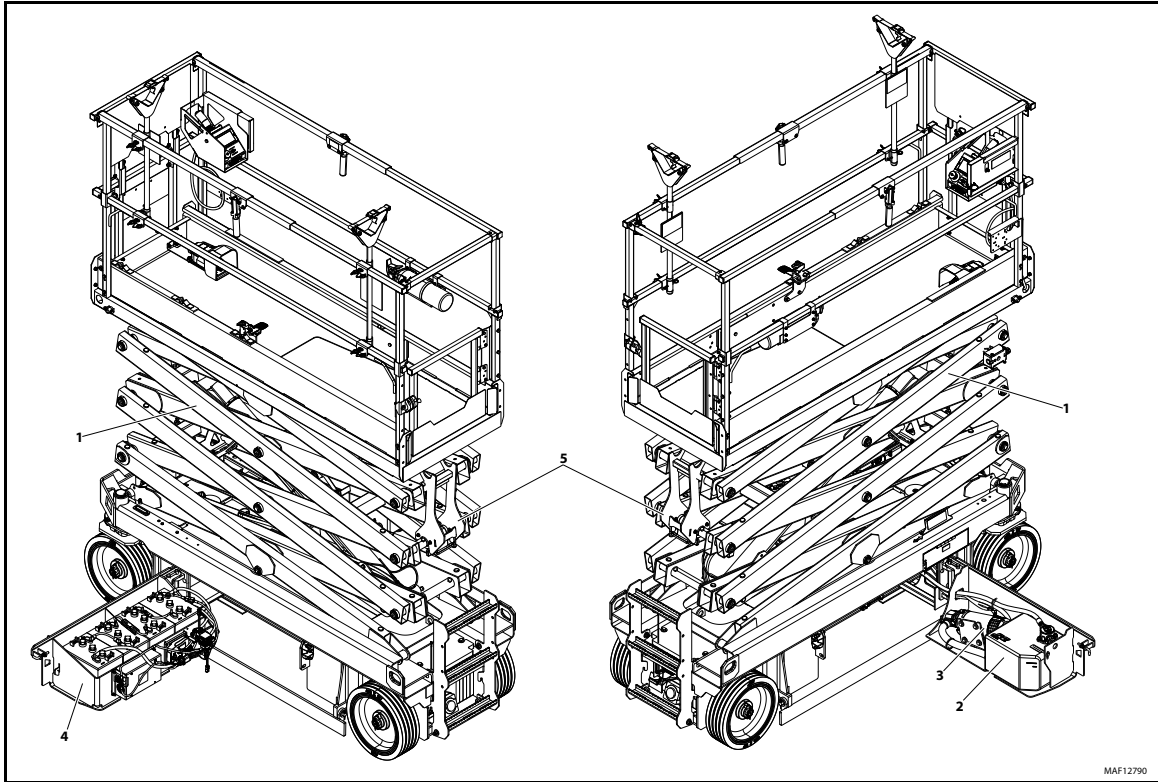

Figure 2-2. Machine Component Locations - R2632

- | | |
|-------------------|-----------------------|
| 1. Scissor Arm | 4. Batteries Location |
| 2. Hydraulic Tank | 5. Safety Prop |
| 3. Pump Assembly | |

Scissor Arm - Safety Prop

(See Figure 2-3. and 2-4.)

⚠ WARNING

NEVER WORK UNDER AN ELEVATED PLATFORM UNTIL IT HAS BEEN RESTRAINED FROM MOVEMENT WITH THE SAFETY PROP, BLOCKING OR OVERHEAD SLING.

⚠ CAUTION

SAFETY PROP MUST BE USED WHENEVER MAINTENANCE PERFORMED ON THE MACHINE REQUIRES THE SCISSOR ARMS TO BE RAISED AND ONLY WITH NO LOAD IN THE PLATFORM.

The safety prop is located in between scissor arms.

To engage the safety prop:

1. From the Ground Control Station, raise the platform approximately 9 ft (2.7 m).
2. At the rear of the machine, pull red safety prop into the vertical position.
3. Lower the platform until the crossbar above the prop comes into contact with the prop.

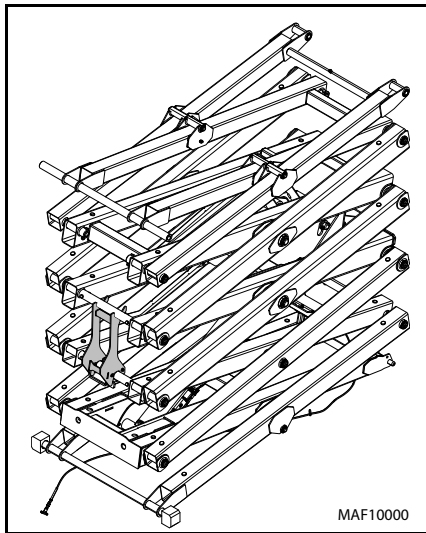

Prop Engaged

Figure 2-3. Scissor Arm - Safety Prop

4. Ensure all downward movement stops when safety prop is engaged.

To disengage the safety prop:

1. Raise the platform enough to release the safety prop.
2. Push in the safety prop.
3. Lower the platform to the stowed position.

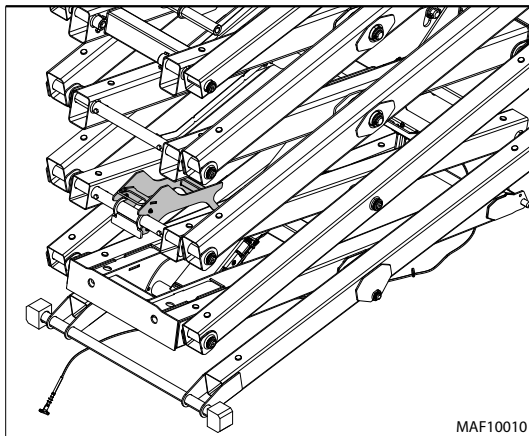

Prop Disengaged

Figure 2-4. Scissor Arm - Safety Prop

Hydraulic Oil Check Procedure

(Figure 2-5., and Figure 2-6.)

- Lube Points - Hydraulic Reservoir
- Reservoir Capacity - 4 gal. (15 L)
- Lube - Hydraulic Oil
- Interval - Check Daily

To ensure proper operation of the machine, the hydraulic oil must be checked daily.

NOTE: Check the hydraulic oil level with the platform in the stowed position only. Be certain the hydraulic oil has warmed to operating temperature before checking the oil level in the reservoir.

1. Open the hydraulic compartment door and locate the hydraulic reservoir (1).
2. Locate the lines indicating the maximum and minimum levels of hydraulic oil (2 and 3) in the reservoir. Ensure the level of oil is between the two lines.
3. If the level of oil in the reservoir is below the minimum level (3), more oil is needed. Wipe all dirt and debris from the filler/filter cap (4) and surrounding area.
4. Remove filler cap and add proper grade of oil. Fill until oil level is close to the maximum level (2). Do not overfill.

NOTE: Take precautions so that impurities (dirt, water, etc.) cannot enter the hydraulic system while filler/filter cap is removed.

NOTE: Recommended lubrication intervals are based on machine operations under normal conditions. For machines used in multi-shift operations and/or exposed to hostile environments or conditions, lubrication frequencies must be increased accordingly.

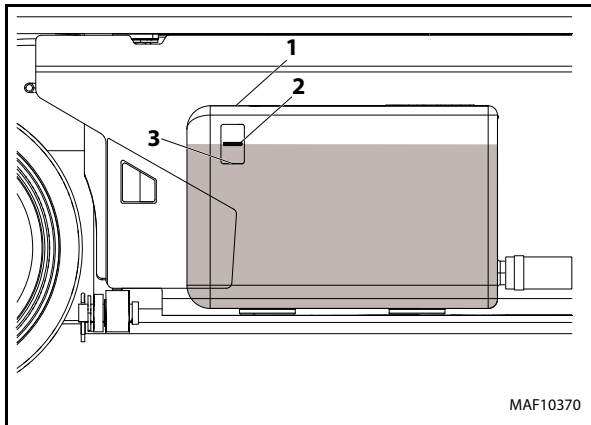

Figure 2-5. Hydraulic Oil Check Procedure

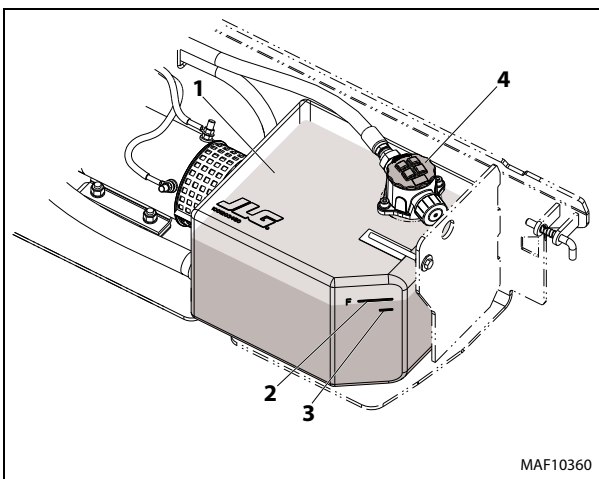

Figure 2-6. Hydraulic Oil Fill Procedure

2.4 SERVICE AND GUIDELINES

General

The following information is provided to assist you in the use and application of servicing and maintenance procedures contained in this book.

Safety and Workmanship

Your safety, and that of others, is the first consideration when engaging in the maintenance of equipment. Always be conscious of weight. Never attempt to move heavy parts without the aid of a mechanical device. Do not allow heavy objects to rest in an unstable position. When raising a portion of the equipment, ensure that adequate support is provided.

Cleanliness

1. The most important single item in preserving the long service life of a machine is to keep dirt and foreign materials out of the vital components. Precautions have been taken to safeguard against this. Shields, covers, seals, and filters are provided to keep air, fuel, and oil supplies clean; however, these items must be maintained on a scheduled basis in order to function properly.
2. At any time when air, fuel, or oil lines are disconnected, clean adjacent areas as well as the openings and fittings themselves. As soon as a line or component is disconnected, cap or cover all openings to prevent entry of foreign matter.
3. Clean and inspect all parts during servicing or maintenance, and assure that all passages and openings are unobstructed. Cover all parts to keep them clean. Be sure all parts are clean before they are installed. New parts should remain in their containers until they are ready to be used.

Components Removal and Installation

1. Use adjustable lifting devices, whenever possible, if mechanical assistance is required. All slings (chains, cables, etc.) should be parallel to each other and as near perpendicular as possible to top of part being lifted.
2. Should it be necessary to remove a component on an angle, keep in mind that the capacity of an eye-bolt or similar bracket lessens, as the angle between the supporting structure and the component becomes less than 90°.
3. If a part resists removal, check to see whether all nuts, bolts, cables, brackets, wiring, etc., have been removed and that no adjacent parts are interfering.

Component Disassembly and Reassembly

When disassembling or reassembling a component, complete the procedural steps in sequence. Do not partially disassemble or assemble one part, then start on another. Always recheck your work to assure that nothing has been overlooked. Do not make any adjustments, other than those recommended, without obtaining proper approval.

Pressure-Fit Parts

When assembling pressure-fit parts, use an anti-seize or molybdenum disulfide base compound to lubricate the mating surface.

Bearings

1. When a bearing is removed, cover it to keep out dirt and abrasives. Clean bearings in nonflammable cleaning solvent and allow to drip dry. Compressed air can be used but do not spin the bearing.
2. Discard bearings if the races and balls (or rollers) are pitted, scored, or burned.
3. If bearing is found to be serviceable, apply a light coat of oil and wrap it in clean (waxed) paper. Do not unwrap reusable or new bearings until they are ready to install.
4. Lubricate new or used serviceable bearings before installation. When pressing a bearing into a retainer or bore, apply pressure to the outer race. If the bearing is to be installed on a shaft, apply pressure to the inner race.

Gaskets

Check that holes in gaskets align with openings in the mating parts. If it becomes necessary to hand-fabricate a gasket, use gasket material or stock of equivalent material and thickness. Be sure to cut holes in the right location, as blank gaskets can cause serious system damage.

Bolt Usage and Torque Application

1. Self locking fasteners, such as nylon insert and thread deforming locknuts, are not intended to be reinstalled after removal. Always use new replacement hardware when installing locking fasteners.
2. Use bolts of proper length. A bolt which is too long will bottom before the head is tight against its related part. If a bolt is too short, there will not be enough thread area to engage and hold the part properly. When replacing bolts, use only those having the same specifications of the original, or one which is equivalent.
3. Unless specific torque requirements are given within the text, standard torque values should be used on heat-treated bolts, studs, and steel nuts, in accordance with recommended shop practices. (See Torque Chart Section 1.)

Hydraulic Lines and Electrical Wiring

Clearly mark or tag hydraulic lines and electrical wiring, as well as their receptacles, when disconnecting or removing them from the unit. This will assure that they are correctly reinstalled.

Hydraulic System

1. Keep the system clean. If evidence of metal or rubber particles are found in the hydraulic system, drain and flush the entire system.
2. Disassemble and reassemble parts on a clean work surface. Clean all metal parts with non-flammable cleaning solvent. Lubricate components, as required, to aid assembly.

Lubrication

Service applicable components with the amount, type, and grade of lubricant recommended in this manual, at the specified intervals. When recommended lubricants are not available, consult your local supplier for an equivalent that meets or exceeds the specifications listed.

Battery

Clean battery, using a non-metallic brush and a solution of baking soda and water. Rinse with clean water. After cleaning, thoroughly dry battery and coat terminals with an anti corrosion compound.

2.5 LUBRICATION AND INFORMATION

Hydraulic System

1. The primary enemy of a hydraulic system is contamination. Contaminants enter the system by various means, e.g., using inadequate hydraulic oil, allowing moisture, grease, filings, sealing components, sand, etc., to enter when performing maintenance, or by permitting the pump to cavitate due to insufficient quantity of oil in supply tube.
2. The design and manufacturing tolerances of the component working parts are very close, therefore, even the smallest amount of dirt or foreign matter entering a system can cause wear or damage to the components and generally results in faulty operation. Every precaution must be taken to keep hydraulic oil clean, including reserve oil in storage. Hydraulic system filters should be checked, cleaned, and/or replaced as necessary, at the specified intervals required, see Table 2-2, Preventive Maintenance & Inspection Schedule Always examine filters for evidence of metal particles.
3. Cloudy oils indicate a high moisture content which permits organic growth, resulting in oxidation or corrosion. If this condition occurs, the system must be drained, flushed, and refilled with clean oil.
4. It is not advisable to mix oils of different brands or types, as they may not contain the same required additives or be of comparable viscosities. Good grade mineral oils, with viscosities suited to the ambient temperatures in which the machine is operating, are recommended for use.

NOTE: *Metal particles may appear in the oil or filters of new machines due to the wear-in of meshing components.*

Hydraulic Oil

1. Refer to Section 1 for recommendations for viscosity ranges.
2. JLG recommends Standard UTTO hydraulic oil, which has an SAE viscosity of 10W-30 and a viscosity index of 152.

NOTE: *Start-up of hydraulic system with oil temperatures below -15°F (-26°C) is not recommended. If it is necessary to start the system in a sub-zero environment, it will be necessary to heat the oil with a low density, electrical heater to a minimum temperature of -15°F (-26°C).*

Changing Hydraulic Oil

1. Use of any of the recommended crankcase or hydraulic oils eliminates the need for changing the oil on a regular basis. However, filter elements must be changed annually unless operating in extreme conditions. If it is necessary to change the oil, use only those oils meeting or exceeding the specifications appearing in this manual. If unable to obtain the same type of oil supplied with the machine, consult local supplier for assistance in selecting the proper equivalent. Avoid mixing petroleum and synthetic base oils. JLG Industries recommends changing the hydraulic oil annually.
2. Use every precaution to keep the hydraulic oil clean. If the oil must be poured from the original container into another, be sure to clean all possible contaminants from the service container. Always replace the filter and clean magnet any time the system oil is changed.
3. While the unit is shut down, a good preventive maintenance measure is to make a thorough inspection of all hydraulic components, lines, fittings, etc., as well as a functional check of each system, before placing the machine back in service.

NOTE: *Refer to section 4 for oil checking and oil changing procedure.*

2.6 CYLINDER DRIFT TEST

Maximum acceptable cylinder drift is to be measured using the following methods.

Platform Drift

Measure the drift of the platform to the ground. Fully elevate the platform. Maximum allowable drift is 2 in. (5 cm) in 10 minutes. If the machine does not pass this test, proceed with the following.

Cylinder Drift

CYLINDER BORE DIAMETER		MAX. ACCEPTABLE DRIFT IN 10 MINUTES	
INCHES	MM	INCHES	MM
3	76.2	0.026	0.66
3.5	89	0.019	0.48
4	101.6	0.015	0.38
5	127	0.009	0.22
6	152.4	0.006	0.15
7	177.8	0.005	0.13

Drift is to be measured at the cylinder rod with a calibrated dial indicator. The cylinder oil must be at ambient temperature and temperature stabilized.

The cylinder must have the normal load, which is the normal platform load applied.

If the cylinder passes this test, it is acceptable.

NOTE: This information is based on 6 drops per minute cylinder leakage.

2.7 PINS AND COMPOSITE BEARING REPAIR GUIDELINES

Filament wound bearings.

1. Pinned joints should be disassembled and inspected if the following occurs:
 - a. Excessive sloppiness in joints.
 - b. Noise originating from the joint during operation.
 2. Filament wound bearings should be replaced if any of the following is observed:
 - a. Frayed or separated fibers on the liner surface.
 - b. Cracked or damaged liner backing.
 - c. Bearings that have moved or spun in their housing.
 - d. Debris embedded in liner surface.
 3. Pins should be replaced if any of the following is observed (pin should be properly cleaned prior to inspection):
 - a. Detectable wear in the bearing area.
 - b. Flaking, peeling, scoring, or scratches on the pin surface.
 - c. Rusting of the pin in the bearing area.
 4. Re-assembly of pinned joints using filament wound bearings.
 - a. Housing should be blown out to remove all dirt and debris, bearings and bearing housings must be free of all contamination.
 - b. Bearing / pins should be cleaned with a solvent to remove all grease and oil.
- NOTE:** Filament wound bearings are dry joints and should not be lubricated.
- c. Pins should be inspected to ensure it is free of burrs, nicks, and scratches which would damage the bearing during installation and operation.

SECTION 3. CHASSIS & SCISSOR ARMS

3.1 LEFT AND RIGHT SIDE COMPARTMENT COMPONENTS

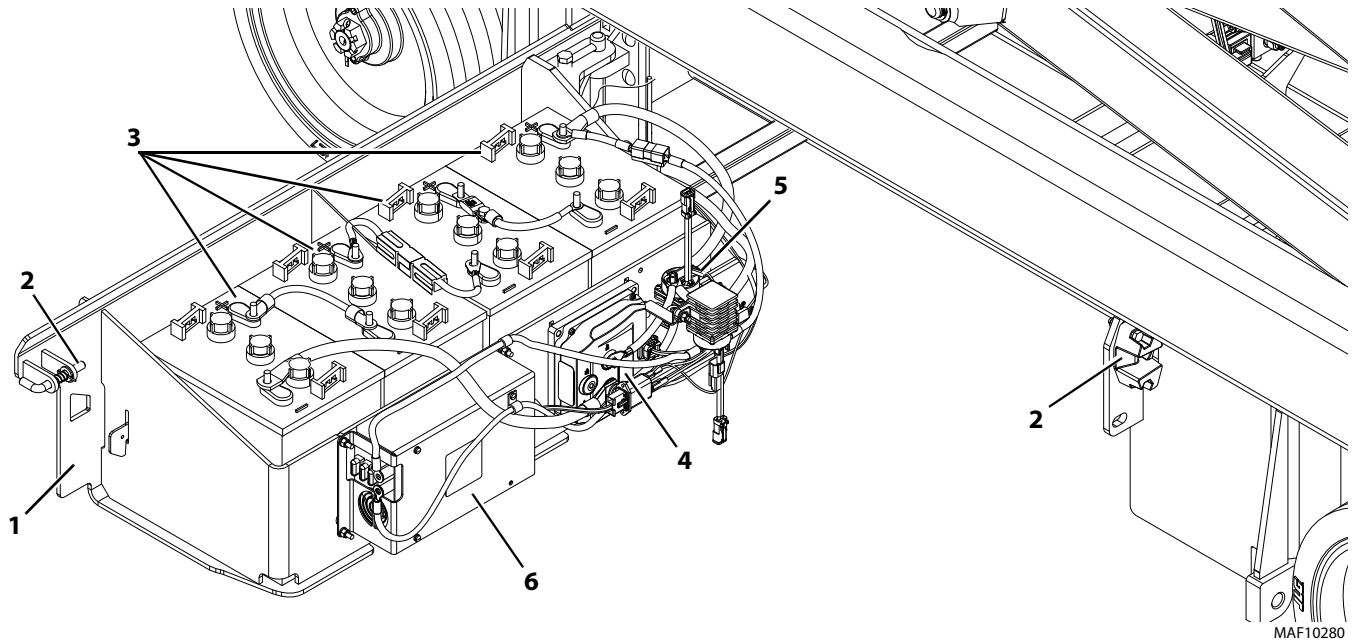

MAF10280

Figure 3-1. Components on Left Side Swing - Out Compartment Door (R2632 and R3246)

- | | |
|---|-------------------------|
| 1. Left Side Component Compartment Door | 4. Pump Power Module |
| 2. Compartment Latch and Release Handle | 5. Main Contactor Relay |
| 3. Batteries | 6. Inverter (Optional) |

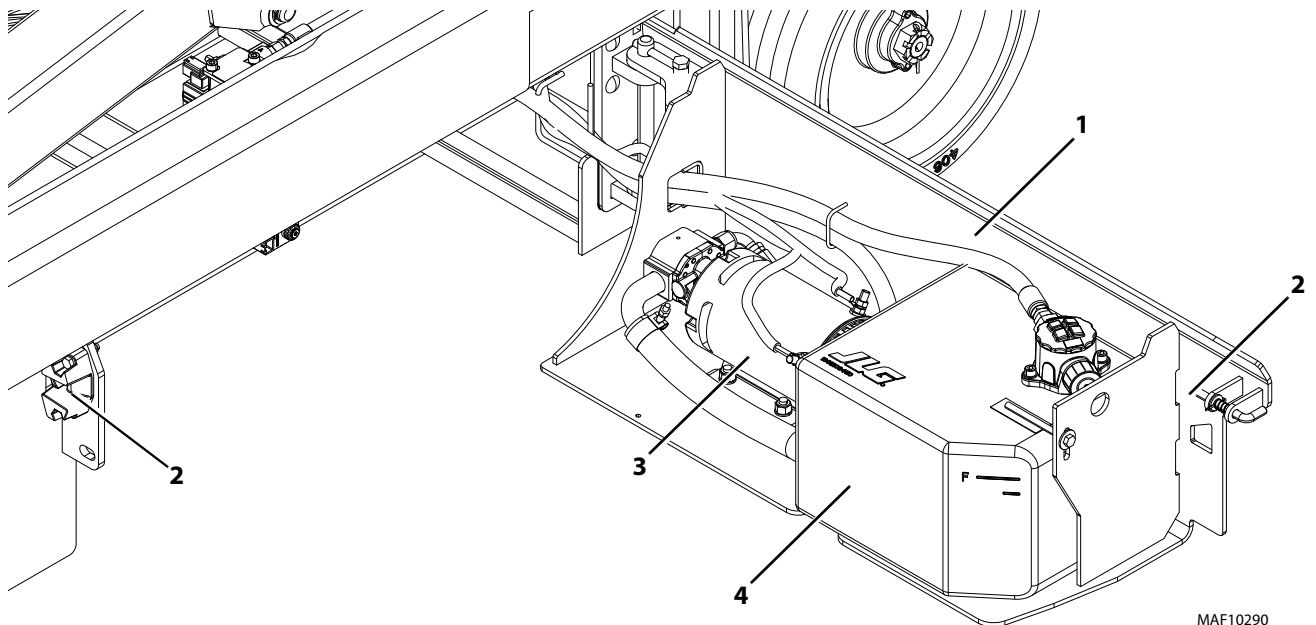

MAF10290

Figure 3-2. Components on Right Side Swing - Out Compartment Door (R3246)

- | | |
|--|----------------------------|
| 1. Right Side Component Compartment Door | 3. Hydraulic Assembly |
| 2. Compartment Latch and Release Handle | 4. Hydraulic Tank w/Filter |

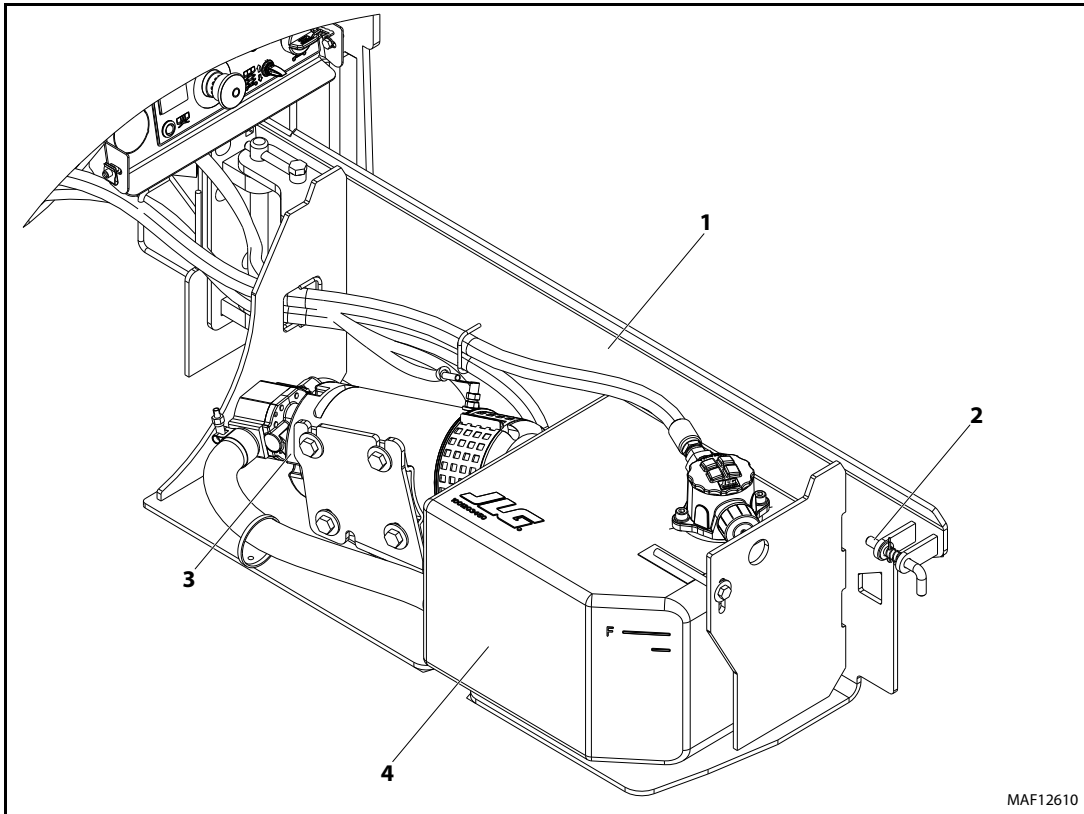

Figure 3-3. Components on Right Side Swing - Out Compartment Door (R2632)

- | | |
|--|----------------------------|
| 1. Right Side Component Compartment Door | 3. Hydraulic Assembly |
| 2. Compartment Latch and Release Handle | 4. Hydraulic Tank w/Filter |

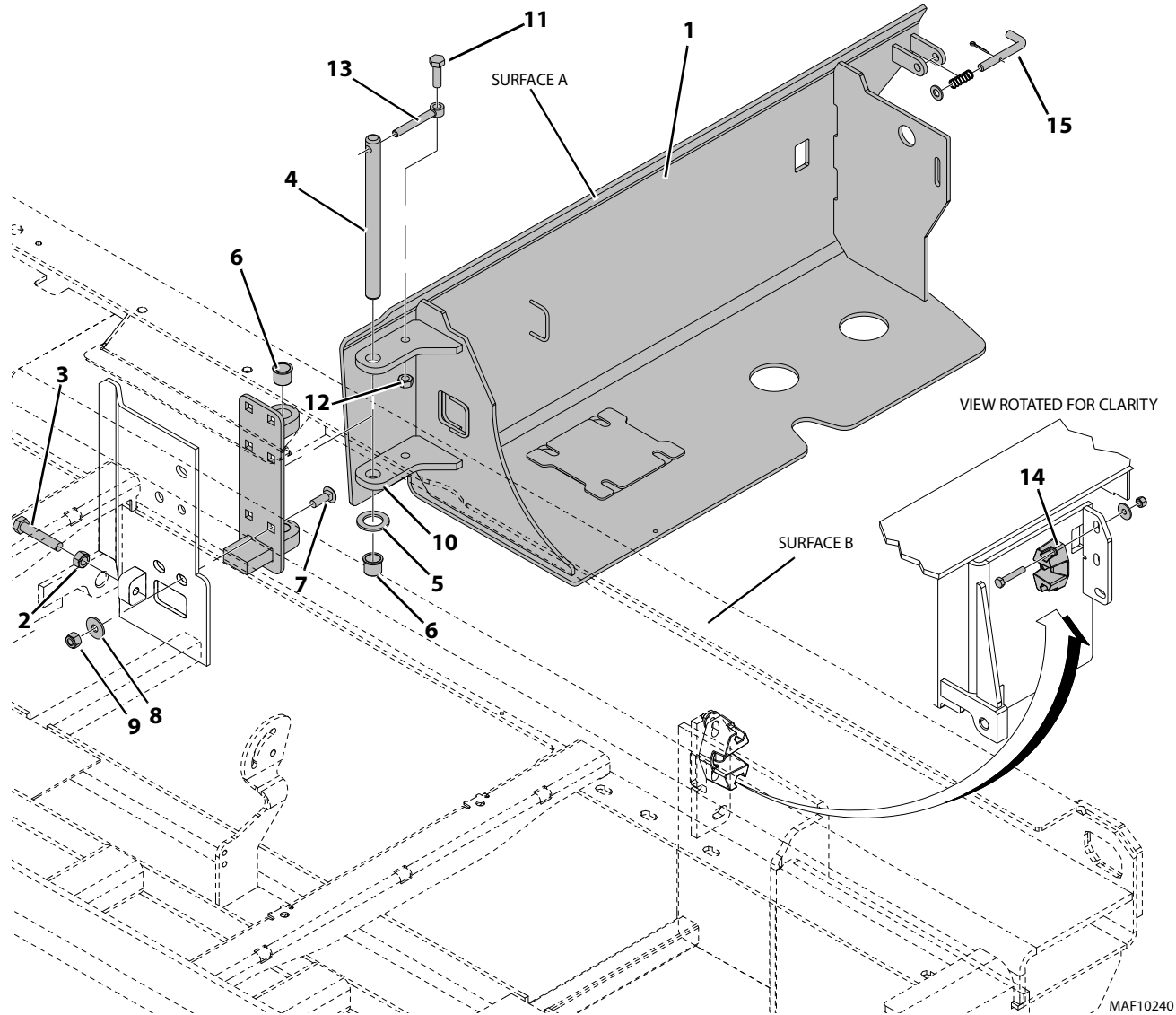

Figure 3-4. Side Swing - Out Compartment Door Installation

- | | | |
|------------------------------------|-----------------------|--------------------|
| 1. Side Compartment Door | 6. Bearing | 11. Bolt |
| 2. Nut | 7. Bolts (See Note 2) | 12. Nut |
| 3. Door Adjuster Bolt (See Note 1) | 8. Washer | 13. Keeper Shaft |
| 4. Hinge Pin Bearing | 9. Nut | 14. Door Latch |
| 5. Thrust Washer | 10. Door Hinge | 15. Door Latch Pin |

NOTE 1: To adjust SURFACE A to be parallel with SURFACE B within 3mm when doors are closed. Rotate the Door Adjuster Bolt in clockwise to decrease and counterclockwise to increase the distance between surface A and B.

NOTE 2: Apply Medium Strength Threadlocking Compound to Bolts before installation.

3.2 BATTERY REMOVAL/MAINTENANCE

NOTICE

JLG MACHINES EQUIPPED WITH DELTA Q BATTERY CHARGERS ARE DESIGNED FOR THE BEST PERFORMANCE WITH OEM FACTORY APPROVED BATTERIES.

APPROVED JLG REPLACEMENT BATTERIES ARE AVAILABLE THROUGH JLG'S AFTERMARKET PARTS DISTRIBUTION CENTERS OR JLG'S AFTERMARKET PROGRAMS. FOR ASSISTANCE WITH PROPER BATTERY REPLACEMENT, PLEASE CONTACT YOUR LOCAL JLG SUPPORT OFFICE. BATTERIES APPROVED BY JLG HAVE BEEN TESTED FOR COMPATIBILITY WITH THE ALGORITHM PROGRAMMING OF THE DELTA Q BATTERY CHARGER TO OPTIMIZE BATTERY LIFE AND MACHINE CYCLE TIMES. THE USE OF NON APPROVED BATTERIES IN YOUR JLG EQUIPMENT MAY RESULT IN PERFORMANCE ISSUES OR BATTERY CHARGER FAULT CODES. JLG ASSUMES NO RESPONSIBILITY FOR SERVICE OR PERFORMANCE ISSUES ARISING FROM THE USE OF NON APPROVED BATTERIES.

Battery Quick-Disconnect

The battery quick-disconnect allows all machine power to be easily disconnected at the batteries without removing battery cables from the battery posts. To disconnect power, locate the RED quick-disconnect connector on top of the



batteries inside the battery compartment and pull halves apart.

CAUTION

BEFORE BATTERY REMOVAL CAN BEGIN, ENSURE THAT THE (+) AND (-) BATTERY CABLES HAVE BEEN PROPERLY DISCONNECTED.

1. The machine batteries are located inside the machine left side compartment door. Release the latch bar at the rear of the door and swing door open.
2. Once the battery door is open, battery replacement/maintenance can begin.
3. To remove one or more batteries from the machine, first disconnect the positive (+) battery cable from the forward most battery connected to the main contractor relay.
4. After any maintenance on the batteries or replacement of the batteries is complete, reconnect the batteries and check for proper operation.
5. Close and latch the left side compartment door.

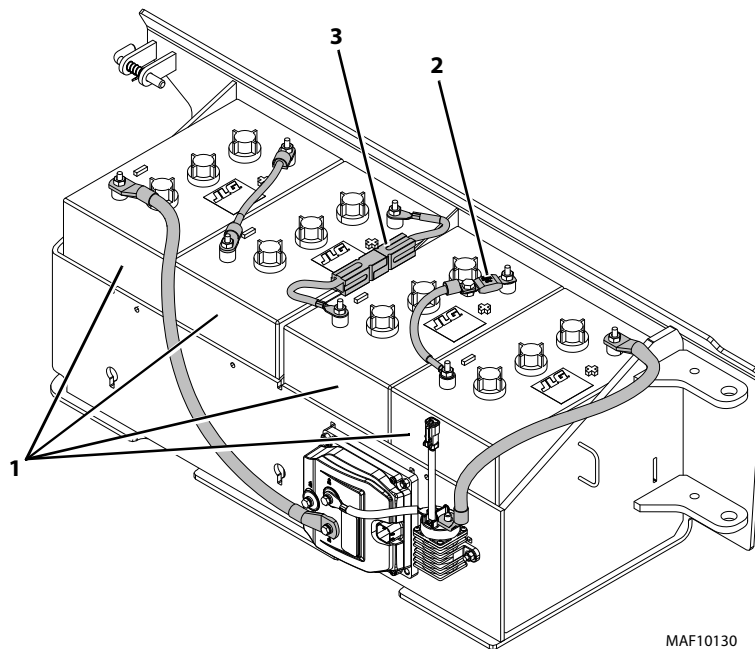

MAF10130

Figure 3-5. Battery Cable Connections

- | | |
|---------------------------|-----------------------------|
| 1. Batteries (6 V) | 3. Battery Quick Disconnect |
| 2. Battery Fuse (250 Amp) | |

Battery Maintenance and Safety Practices

Non-Sealed - Refillable Lead Acid Batteries Only

⚠ CAUTION

ENSURE THAT BATTERY ACID DOES NOT COME INTO CONTACT WITH SKIN OR CLOTHING. WEAR PROTECTIVE CLOTHING AND EYEWEAR WHEN WORKING WITH BATTERIES. NEUTRALIZE ANY BATTERY ACID SPILLS WITH BAKING SODA AND WATER.

BATTERY ACID RELEASES AN EXPLOSIVE GAS WHILE CHARGING, ALLOW NO OPEN FLAMES, SPARKS OR LIGHTED TOBACCO PRODUCTS IN THE AREA WHILE CHARGING BATTERIES. CHARGE BATTERIES ONLY IN A WELL VENTILATED AREA.

ADD ONLY DISTILLED WATER TO BATTERIES. WHEN ADDING DISTILLED WATER TO THE BATTERIES, A NON-METALLIC CONTAINER AND/OR FUNNEL MUST BE USED.

⚠ WARNING

DO NOT REPLACE ITEMS CRITICAL TO STABILITY, SUCH AS BATTERIES, WITH ITEMS OF DIFFERENT WEIGHT OR SPECIFICATION. DO NOT MODIFY UNIT IN ANY WAY TO AFFECT STABILITY.

Check the electrolyte level of the batteries often, adding only distilled water when required. When fully charged, battery fluid level should be 1/8 in. below vent tubes. (See Figure 3-6.)

- DO NOT fill to bottom of vent tubes.
- DO NOT allow fluid level to go below the top of the plates when charging or operating.

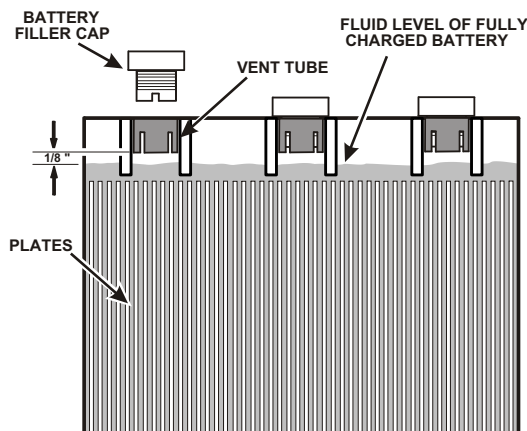

Figure 3-6. Battery Fluid Level

3.3 BATTERY CHARGING

NOTE: Be sure that machine is parked in a well ventilated area before charging begins.

⚠ CAUTION

ONLY PLUG THE CHARGER INTO A PROPERLY INSTALLED AND GROUNDED OUTLET. DO NOT USE GROUND ADAPTORS OR MODIFY PLUG. DO NOT TOUCH NON-INSULATED PORTION OF OUTPUT CONNECTOR OR NON-INSULATED BATTERY TERMINAL.

DO NOT OPERATE CHARGER IF THE AC SUPPLY CORD IS DAMAGED OR IF THE CHARGER HAS RECEIVED A SHARP BLOW, BEEN DROPPED, OR OTHERWISE DAMAGED IN ANY WAY.

ALWAYS DISCONNECT THE CHARGER AC SUPPLY BEFORE MAKING OR BREAKING THE (POSITIVE/NEGATIVE) CONNECTIONS TO THE BATTERY. DO NOT OPEN OR DISASSEMBLE CHARGER.

1. The battery charger AC input plug is located inside the frame at the left rear of the machine next to the battery charger.
2. Connect the charger AC input plug to a grounded outlet using a 3 wire heavy duty extension cord (See Table 1-1, Battery Charger Specifications, for battery charger AC input specifications).
3. After connecting the charger to an AC outlet at the start of the charging cycle, check the LED indicators on the charger for normal operation or if a fault has occurred.
4. Current battery charge state can also be seen on the platform control station panel LEDs, or the MDI indicator (if equipped) on the ground control station, when machine is powered up.
5. The batteries are fully charged when all three GREEN LED indicators on the platform control station or MDI battery charger status panel are illuminated.

NOTE: If the charger is left plugged in, the charger will automatically restart a complete charge cycle if the batteries voltage drops below a minimum voltage or 30 days has elapsed.

Delta-Q - Battery Charger

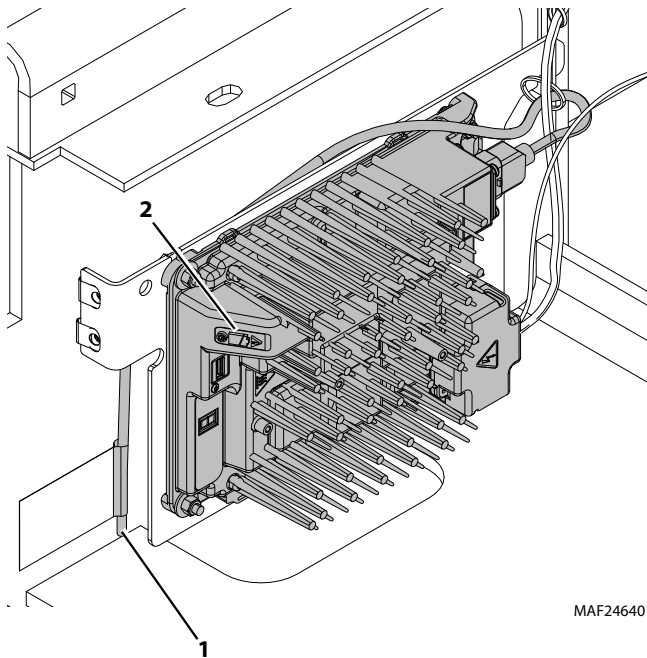

MAF24640

1. AC Voltage Input 2. Charge Indicator LEDs

- **AC Power On:** Blue LED on
- **Low State of Charge:** Bottom Panel - Green LED flashing; Top Panel - Green LED off
- **High State of Charge:** Bottom Panel - Green LED on; Top Panel - Green LED flashing
- **Charge Complete:** Bottom Panel - Green LED on; Top Panel - Green LED on
- **Fault Indicator:** Red LED on
- **External Error Condition Caution:** Amber LED flashing

Green Power - Battery Charger - (China (GB) Only)

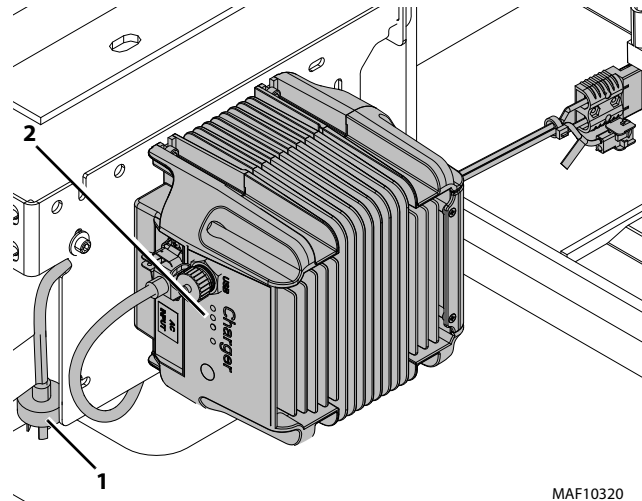

MAF10320

1. AC Voltage Input Cable 2. Charge Indicator LEDs

- **Battery Charging:** Yellow LED - AGM - flashes quickly; Flooded - remains on / AGM flooded - flashes slowly
- **Charge Complete:** Green LED on
- **Fault Indicator:** Red LED on
- **Performing Self-Diagnostic:** Yellow and green LEDs flashing simultaneously.

Eagle Performance - Battery Charger

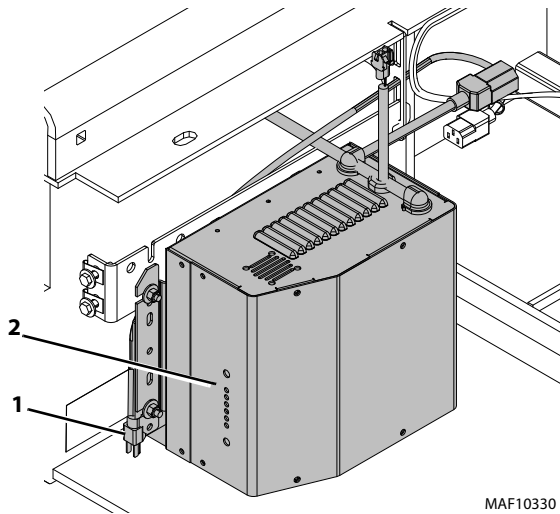

1. AC Voltage Input Cable 2. Charge Indicator LEDs

- **Battery Type Indicator:** Yellow LED on
- **Battery Charging:** 30%-60%-90% Red LED on
- **Charge Complete:** Green LED on
- **No Battery Detected:** 30% Red LED blinking
- **Overall Timer Shutdown:** 30-60-90% Red LEDs blinking
- **Internal OverTemp Shutdown:** 30-90% Red LEDs blinking

Battery Charger Maintenance

⚠ CAUTION

USE CHARGER ONLY ON BATTERY SYSTEMS WITH AN ALGORITHM SELECTED THAT IS APPROPRIATE TO THE SPECIFIC BATTERY TYPE. OTHER USAGE MAY CAUSE PERSONAL INJURY AND DAMAGE.

LEAD ACID BATTERIES MAY GENERATE EXPLOSIVE HYDROGEN GAS DURING NORMAL OPERATION. KEEP SPARKS, FLAMES, AND SMOKING MATERIALS AWAY FROM BATTERIES. PROVIDE ADEQUATE VENTILATION DURING CHARGING. NEVER CHARGE A FROZEN BATTERY.

STUDY ALL BATTERY MANUFACTURER'S SPECIFIC PRECAUTIONS SUCH AS RECOMMENDED RATES OF CHARGE AND REMOVING OR NOT REMOVING CELL CAPS WHILE CHARGING.

⚠ CAUTION

ONLY PLUG THE CHARGER INTO A PROPERLY INSTALLED AND GROUNDED OUTLET. DO NOT USE GROUND ADAPTERS OR MODIFY PLUG. DO NOT TOUCH NON-INSULATED PORTION OF OUTPUT CONNECTOR OR NON-INSULATED BATTERY TERMINAL.

DO NOT OPERATE CHARGER IF THE AC SUPPLY CORD IS DAMAGED OR IF THE CHARGER HAS RECEIVED A SHARP BLOW, BEEN DROPPED, OR OTHERWISE DAMAGED IN ANY WAY.

ALWAYS DISCONNECT THE CHARGER AC SUPPLY BEFORE MAKING OR BREAKING THE (POS/NEG) CONNECTIONS TO THE BATTERY. DO NOT OPEN OR DISASSEMBLE CHARGER.

1. For flooded lead-acid batteries, regularly check water levels of each battery cell after charging and add distilled water as required to level specified by battery manufacturer. Follow the safety instructions recommended by the battery manufacturer.
2. Make sure charger connections to battery terminals are tight and clean.
3. Do not expose charger to oil or to direct heavy water spraying when cleaning vehicle.

Excessive Battery Watering Requirements or Strong Sulphur (Rotten Egg) Smell

These symptoms indicate over-charging or high battery temperature. These symptoms are unlikely to be caused by too high a charge current since the maximum charge current of the charger will be small compared to even a moderately sized battery pack. The most likely cause for this problem is incorrect charge algorithm setting and/or high ambient temperatures.

1. Confirm that the battery pack is not too small - usually > 50Ah.
2. Confirm that the nominal battery voltage matches the charger output voltage.
3. If the output voltage of the charger seems excessive, return the charger for service. Contact JLG to get the expected battery voltage settings for the charger in question. Be sure to have the charger's serial number and charge algorithm setting available when calling.

Table 3-1. Diagnostic Trouble Codes (Delta Q Battery Charger)

DTC	Fault	Solution
E-0-0-1 E-0-2-1	Battery high voltage	Check the battery voltage and cable connections. Check battery size and condition. This error will automatically clear once the condition has been corrected.
E-0-0-2 E-0-2-2	Battery low voltage	Check the battery voltage and cable connections. Check battery size and condition. This error will automatically clear once the condition has been corrected.
E-0-0-3	Charge timeout caused by battery pack not reaching required voltage within safe time limit.	Possible causes: Charger output reduced due to high temperatures, poor battery health, very deeply discharged battery and /or poorly connected battery. Possible solutions: Operate at lower ambient temperature. Replace battery pack. Check DC connections. This error will automatically clear once the charger is reset by cycling DC.
E-0-0-4	Battery could not meet minimum voltage	Check for shorted or damaged cells. Replace battery pack. Check DC connections. This error will automatically clear once the charger is reset by cycling DC.
E-0-0-7	Battery amp hour limit exceeded	Possible causes include poor battery health, very deeply discharged battery, poorly connected battery, and / or high parasitic loads on battery while charging. Possible solutions: Replace battery pack. Check DC connections. Disconnect parasitic loads. This error will automatically clear once the charger is reset by cycling DC.
E-0-0-8	Battery temperature is out of range	Possible battery temperature sensor error. Check temperature sensor and connections. Reset charger. This error will automatically clear once the condition has been corrected.
E-0-1-2	Reverse polarity error	Battery is connected to the charger incorrectly. Check the battery connections. This error will automatically clear once the condition has been corrected.
E-0-1-6 E-0-1-8 E-0-2-6	USB operation failed	Software upgrade failure or script operation failure. Ensure the USB flash drive is properly formatted and retry inserting the USB flash drive into the charger.
E-0-2-3	High AC voltage error (>270VAC)	Connect charger to an AC source that provides stable AC between 85 - 270VAC / 45 - 65 Hz. This error will automatically clear once the condition has been corrected.
E-0-2-4	Charger failed to initialize	The charger has failed to turn on properly. Disconnect AC input and battery for 30 seconds before retrying.
E-0-2-5	Low AC voltage oscillation error	AC source is unstable. Could be caused by undersized generator and /or severely undersized input cables. Connect charger to an AC source that provides stable AC between 85 - 270VAC / 45-65 Hz. This error will automatically clear once the condition has been corrected.
F-0-0-1, F-0-0-2, F-0-0-3, F-0-0-4, F-0-0-6		Internal charger fault. Remove AC and battery for minimum 30 seconds and retry charger. If it fails again, please contact the manufacturer of your vehicle or machine.

Table 3-2. Fault Codes (Green Power)

Flash Code	Cause	Solution
1	Connection Issue	1) Check battery connection is correct. 2) Check charger connection is correct. 3) Check each battery is good.
2	Abnormal AC Power Input (Voltage)	1) Check AC input cord is connected between charger and AC outlet. 2) Make sure AC plug is tightly secured into AC outlet.
3	Charger High Temperature Protection	1) Charger shuts down and goes into protection mode due to charger/environmental temperature is too high for charger to function properly. Please place the charger into an area with ambient air flow or to a cooler place. 2) Disconnect the charger and wait for 15-20 mins before reconnecting for charging.
4	Battery High Temperature Protection	1) Charger will reduce or even stop charging when the battery temperature exceeds 50° C. This is to avoid battery overheating. 2) Disconnect the charger and wait for 15-20 mins before reconnecting for charging.
5	Output Current is too high	Return to factory for repair.
6	Battery Voltage is too high(>30.5V)	Check and assure that the correct output battery voltage is connected.
7	Battery Voltage is too low(<18V)	Check and assure that the correct output battery voltage is connected.

Table 3-3. Fault Codes (Eagle Battery Charger)

LED Indications	Fault	Solution
30% RED LED BLINKING	NO BATTERY DETECTED	This indication occurs whenever the charger circuitry cannot detect a battery. The charger circuitry will not allow charge current to flow under this condition. With the AC power supply cord unplugged, check the connection to the batteries for proper polarity (black wire to negative). Also check for corrosion free secure connections to the battery.
30 & 60% RED LEDS BLINKING	FORMING STAGE TIMEOUT SHUTDOWN	This indication occurs if the battery voltage has not risen above 1.75 volts per cell within the first 3 hours of charging. This indicates that a possible battery problem exists and that the charge cycle has been terminated at this point.
30, 60 & 90% RED LEDS BLINKING	OVERALL TIMER SHUTDOWN	This indication occurs if the charger has not completed the charge cycle within the allowable factory set time period. This indicates that a possible battery problem exists and that the charge cycle has been terminated at this point.
30 & 90% RED LEDS BLINKING	INTERNAL OVERTEMP SHUTDOWN	This indication occurs if the charger circuitry has detected operating temperatures inside the charger enclosure that are above factory specified levels. This could indicate that a possible charger problem exists and that the charge cycle has been terminated.
30% RED & 100% GREEN LEDS BLINKING	BULK STAGE SHUTDOWN	This indication occurs if the battery voltage does not rise properly during the Bulk Stage. This indicates that a possible battery problem exists and that the charge cycle has been terminated at this point.
30% RED & 100% GREEN LEDS ALTERNATE BLINKING ON OFF	DELTAVIEW SIGNAL OR NO BATTERY DETECTED	This will be the NORMAL indication when the charger is plugged into A/C but not connected to a battery pack, allowing the Delta View signal to be retrieved with a Delta View Reader. This can also be considered the NO BATTERY DETECTED fault code.
NOTE: Disconnecting and reconnecting the AC power supply cord will reset the charger.		

3.4 DC/AC POWER INVERTER INSTALLATION - OPTION

DESCRIPTION	ALL MACHINES
Electrical System Voltage (DC)	24V
Power Inverter:	Power Bright
DC Input:	
DC Input Voltage:	20 to 30VDC
Operating Temperature:	-4°F (-20°C) to 113°F (+45°C)
AC Output:	
Output Power (Continuous):	900W
Output Power (Surge):	1800W
Output Power (AC):	7.5A
Output Voltage (AC):	117V +/- 10%
Output Frequency:	60 Hz
Type:	Modified Sine Wave
Protection:	
Out put Reverse DC Polarity:	3 X 25A Replaceable Fuse

Set the master power switch (*item 5*) on the side of the inverter unit to ON and leave it there. Use the inverter on/off switch at the Ground Control panel (see Ground Control Station - page 3-16, item 3) to power the inverter on and off, via the DC power contactor relay (*item 6* in illustration below).

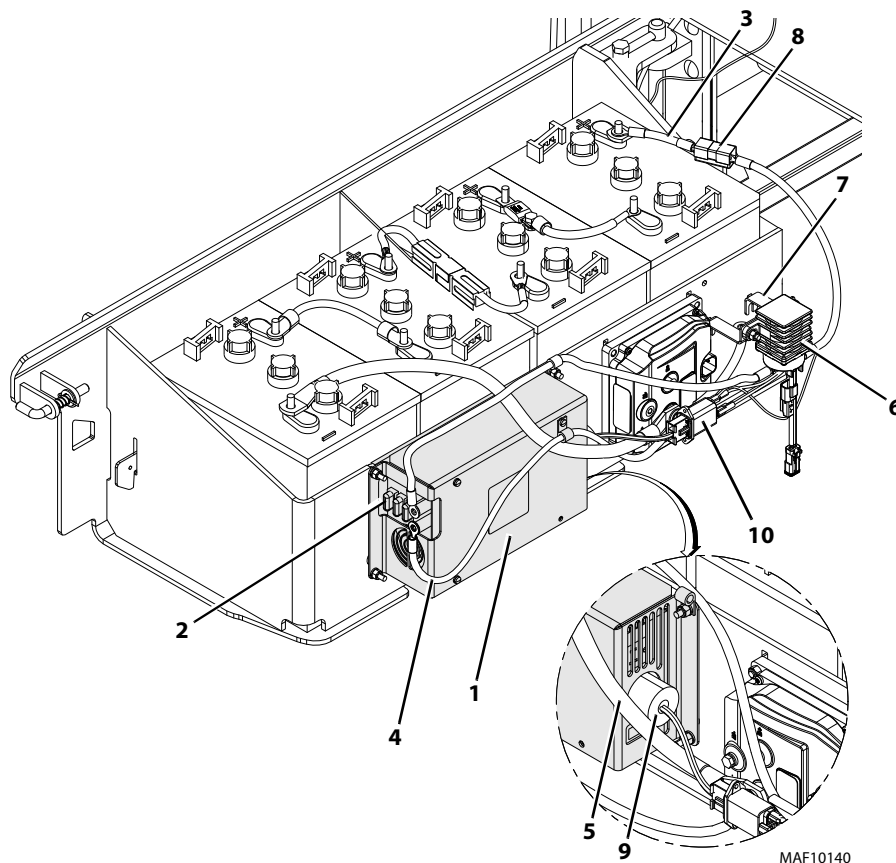

Figure 3-7. DC/AC Power Inverter - Installation

1. DC/AC Power Inverter
2. DC Input Fuses (3 X 25 Amp Each)
3. DC (+) Positive Input from Batteries
4. DC (-) Negative Input from Batteries
5. Inverter Master Power Switch (On Side Panel)
6. DC Power Contactor Relay
7. Contactor Relay Mounting Bracket and Hardware
8. DC (+) Positive 80Amp Inline Fuse For Inverter Circuit Power Feed
9. AC Power Output to Platform Receptacle Cable
10. AC Line Filter

3.5 LOGIC CONTROL MODULE INSTALLATION

All machine electrical functions are controlled through the logic control module, the logic control module also monitors all the machine's electrical systems. If a system fault should happen with the logic module or one of the machine's electrical systems, the logic module will generate a DTC code. Refer to the DTC (Diagnostic Trouble Codes), see Section 6, Diagnostic Trouble Codes for diagnostic information concerning any DTC code generated by the logic module.

The logic control module is located on the machine chassis inside the right side compartment door.

Module Access

1. Open the right side compartment to access the logic control module.

Removing Module from Machine

1. Disconnect machine power at the positive (+) battery cable or use quick disconnect.
2. Mark or note the harness connector positions before removing from the module.
3. Disconnect the harness connectors from the front of the module.
4. Remove the three bolts, nuts and washers, two on top and one on bottom of module, to remove the module from door plate.

Re-install by reversing the above steps.

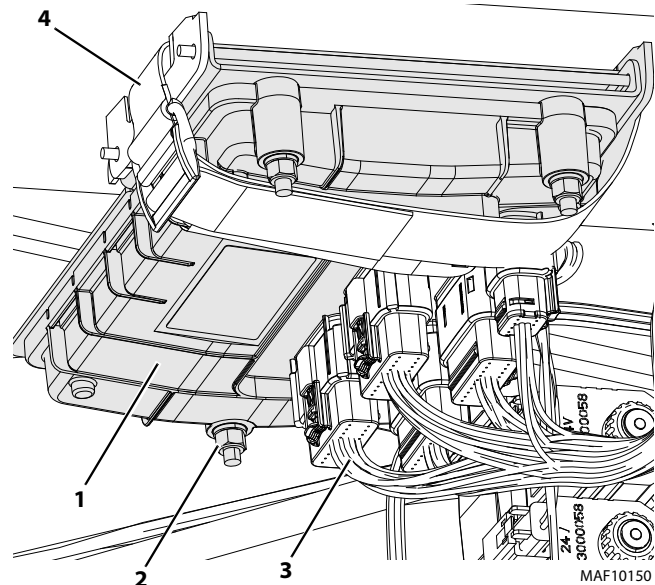

Figure 3-8. Logic Module Components

- | | |
|---|----------------------------|
| 1. Logic Module Assembly | 3. Main Harness Connectors |
| 2. Module Mounting Bolts/Nuts and Washers | 4. Clinch Strap |

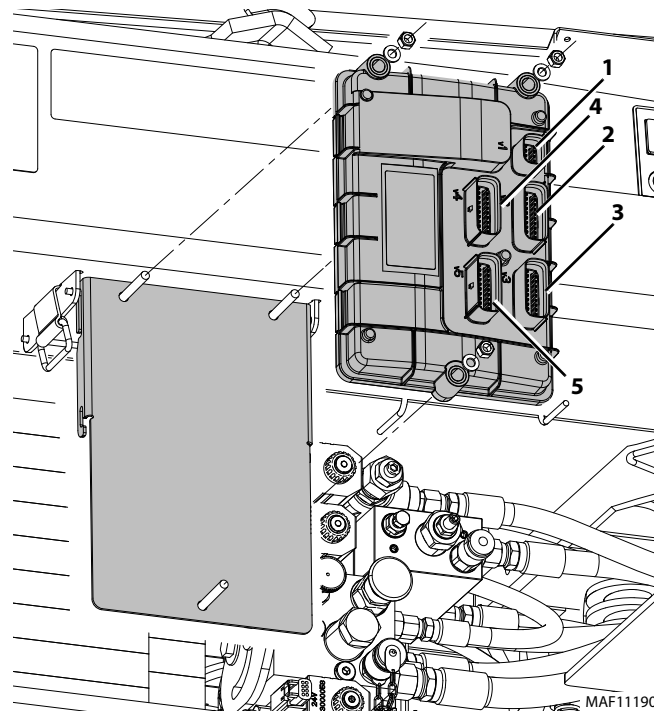

Figure 3-9. Logic Module C001 - Harness Connector Identification

- | | |
|---------------------------------|---------------------------------|
| 1. C001 - V1 Connector - 8 Pin | 4. C001 - V4 Connector - 20 Pin |
| 2. C001 - V2 Connector - 20 Pin | 5. C001 - V5 Connector - 20 Pin |
| 3. C001 - V3 Connector - 20 Pin | |

NOTE: For detailed connector pin assignments see the Electrical Schematic in Section 8.

3.6 MAIN POWER CONTACTOR RELAY AND PUMP CONTROL MODULE

The main power contactor relay and pump control module are located on the left side swing out compartment door, next to the batteries.

NOTICE

DISCONNECT MAIN POWER FROM THE BATTERIES BEFORE ATTEMPTING TO REMOVE THE MAIN POWER CONTACTOR RELAY OR SERVICING THE ELECTRICAL SYSTEM. FAILURE TO DO SO COULD CAUSE DAMAGE TO THE MACHINES ELECTRICAL COMPONENTS.

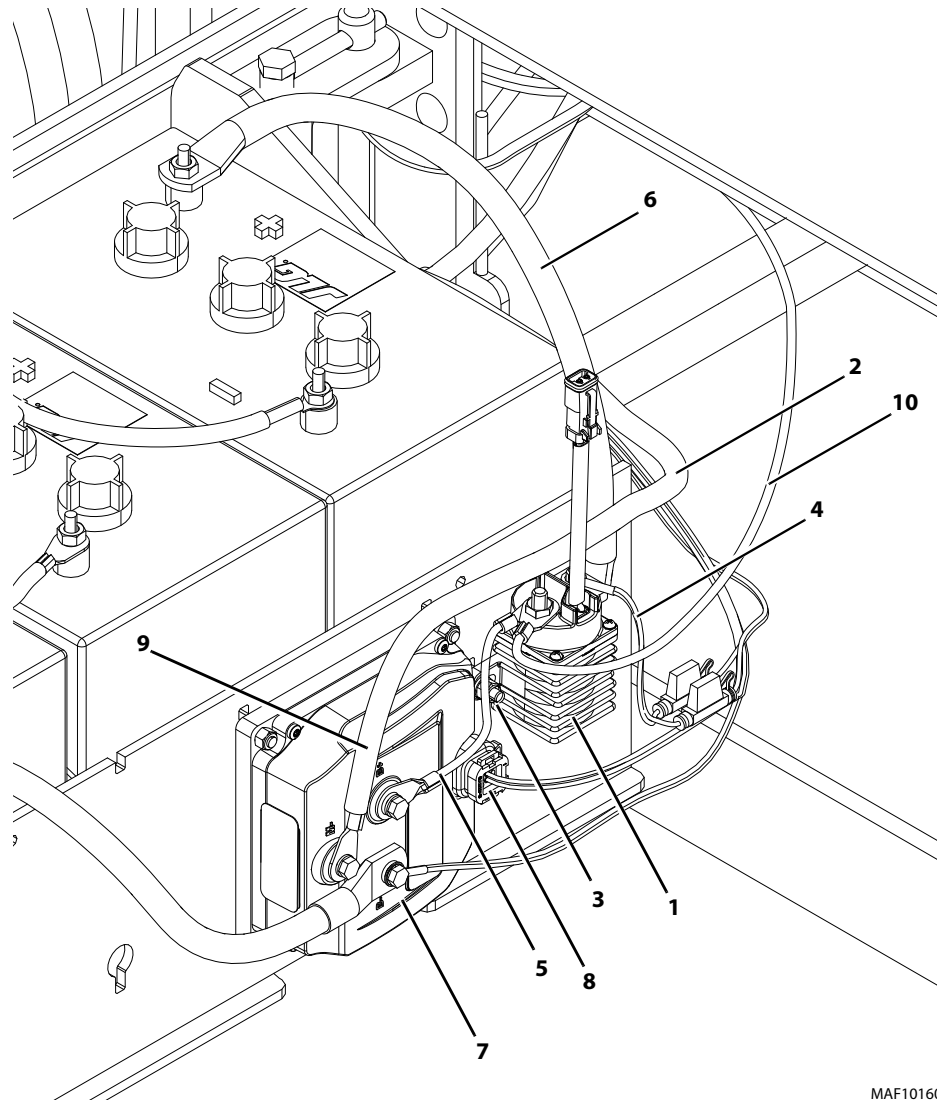

MAF10160

- | | |
|--|--|
| <ul style="list-style-type: none"> 1. Main Power Contactor Relay 2. Battery (+) Cable 3. Mounting Bolts, Nuts and Washers 4. From Machine Logic Control Module 5. To Pump Controller B (+) Post | <ul style="list-style-type: none"> 6. Battery Charger Output (+) To Battery (+) Cable 7. Pump Control Module 8. Connector CO02- J1 - Wires From Logic Controller 9. M (-) Cable to Hyd. Pump 10. Contactor to Hyd. Pump |
|--|--|

3.7 PUMP CONTROL MODULE

The pump control module (item 7 - "Main Power Contactor Relay and Pump Control Module" on page 3-13) is located inside the left side component door, mounted to the side of the battery box. Use the following instructions when replacing the pump control module.

Removal

1. Turn machine power off.
2. Open the left side component door on the machine, disconnect the battery (+) terminal.
3. Tag and note the cable/wire terminal locations before removing the pump control module.
4. Disconnect all wire connectors and cables from the pump control module and remove it from the machine.

Installation

1. When installing the pump control module, be sure that the terminals are oriented as shown in "Main Power Contactor Relay and Pump Control Module" on page 3-13.
2. After installing the new power module, begin connecting the wire connectors/cables to the module.
3. Torque all terminal bolts to torque specifications as shown in Table 3-4. Overtightening could damage the module.
4. After all connections to the pump module are made, the batteries can be reconnected.
5. Close the left side compartment door.
6. Power up machine and check for normal machine operation.

Table 3-4. Pump Control Module Specifications

Nominal Voltage:	24V
IGN Active Range:	8 to 40V
Normal Operation:	12 to 36V
Current Cutback Above	185°F (85°C)
Voltage:	
Under Voltage Cutback:	12V
Under Voltage Cutback Rate:	Linear
Under Voltage Cutoff:	9.6V
Over Voltage Cutoff:	36V
Maximum Current Limits	
2 Min. Continuous:	300 A
1 Hr. Continuous:	120 A at 50% duty cycle
Terminal Bolt Torque:	80-100 in. lbs. (9.1-11.3 Nm)

Table 3-5. Pump Power Module Terminal Functions (CO117-J1)

J1-1	Power Input (8-40V) - Input
J1-2	Speed Command Input (0-5V) - Input
J1-3	Low-Side Driver for Contactor - Output
J1-4	CAN BUS High Signal - Input/Output
J1-5	CAN BUS Low Signal - Input/Output
J1-6	Active High Input (24V ON/OV OFF) - Input
J1-7	No Connect
J1-8	No Connect

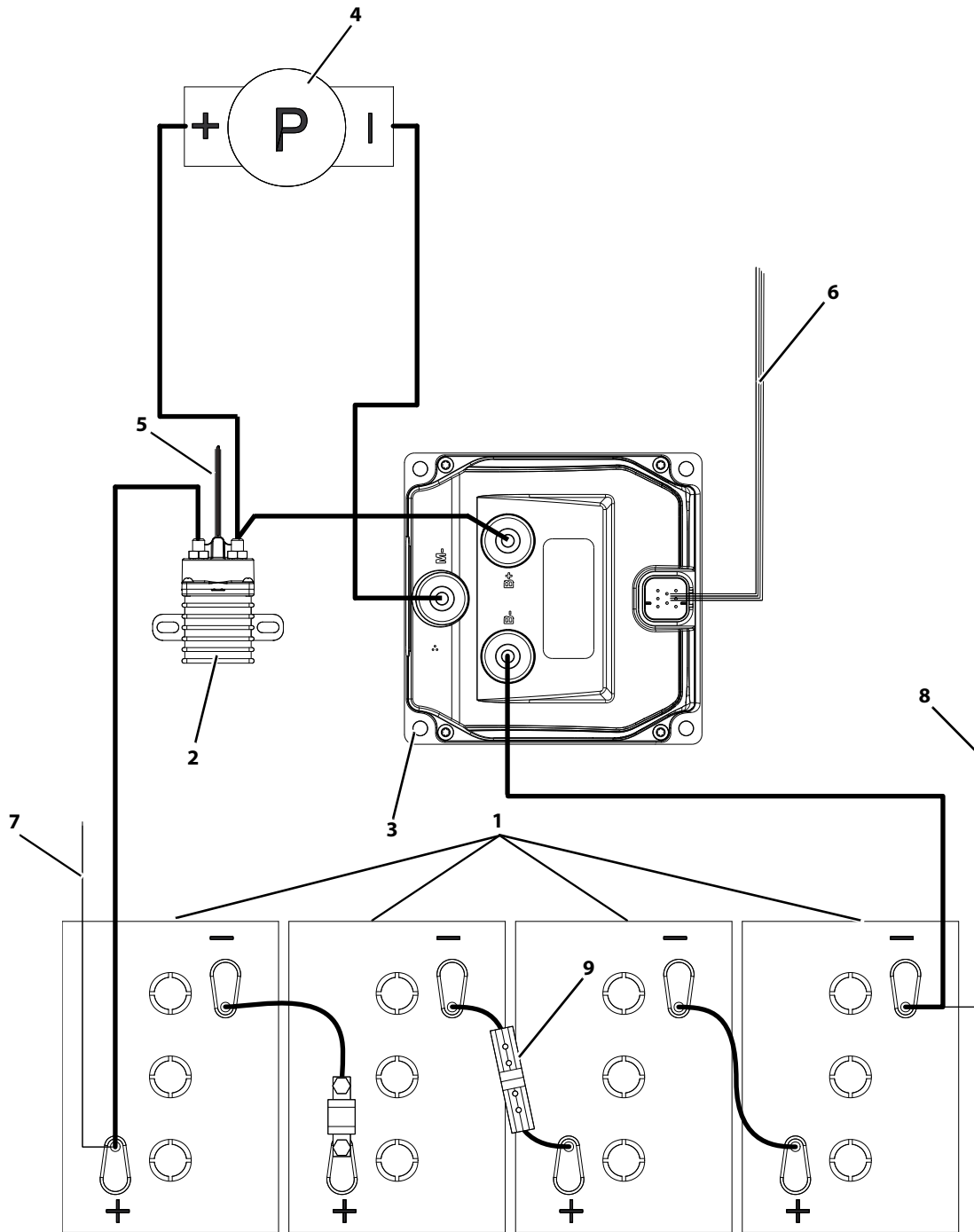

MAF10170

Figure 3-10. Hydraulic Pump Control - Power Connections

- | | |
|-------------------------------|----------------------------|
| 1. Batteries | 6. To Logic Control Module |
| 2. Main Power Contactor Relay | 7. To Battery Charger (+) |
| 3. Pump Control Module | 8. To Battery Charger (-) |
| 4. Hydraulic Pump Motor | 9. Battery Mega Fuse |
| 5. To Logic Module Controller | |

3.8 GROUND CONTROL STATION

Components Location

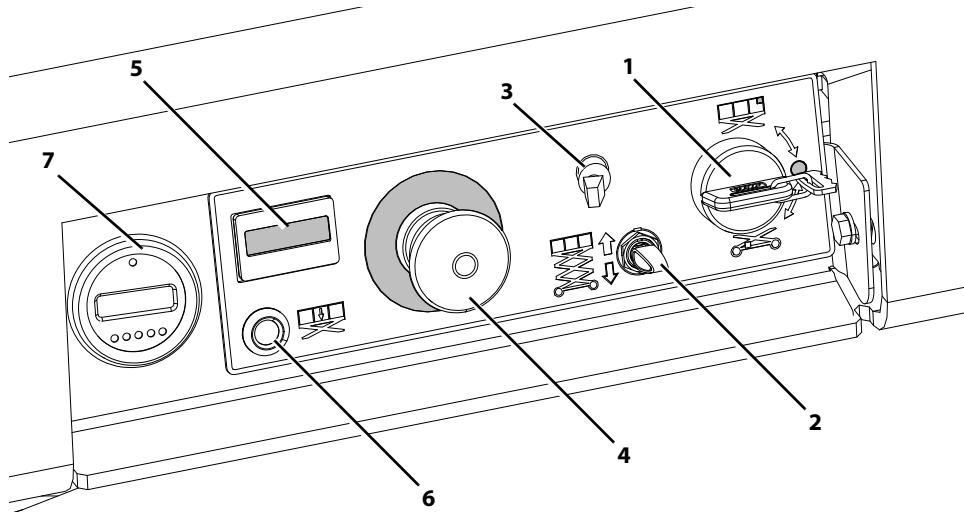

MAF10180

- | | |
|--|----------------------------------|
| 1. Ground/Platform/OFF Key Selector Switch | 5. Hourmeter Gauge |
| 2. Platform Lift/Lower Switch | 6. Overload Indicator |
| 3. Inverter ON/OFF Switch (If Equipped) | 7. MDI - Indicator (If Equipped) |
| 4. Ground Emergency Stop Button | |

NOTICE

DISCONNECT MAIN POWER FROM THE BATTERIES BEFORE ATTEMPTING TO SERVICE THE ELECTRICAL SYSTEM. FAILURE TO DO SO COULD CAUSE DAMAGE TO THE MACHINES ELECTRICAL COMPONENTS.

Removal

1. Disconnect battery power from the machine.
2. Lift the rear panel cover flap to gain access to the mounting nuts on the control station bracket mounting bolts.
3. Remove two screws, washers and tinnerman nuts attaching the ground control panel to the frame.
4. When panel is released, lift and remove protective rear cover and put aside.
5. Rotate the ground control station and disconnect the desired connectors and remove components on the back of the panel.

Installation

1. Check that all components are installed into the control station panel and connected to the wiring harness on the back of the panel.
2. Insert the control station into position on the machine and align the mounting holes in the panel with the mounting holes in the frame.
3. Insert the rear panel cover (flap) between the frame and the control station bracket. Align the holes in the cover with the holes in the frame, and control station bracket.
4. Attach using two mounting screws, washers and tinnerman nuts. Tighten securely the hardware.
5. Reconnect the battery power to the machine, start the machine and check machine operation.

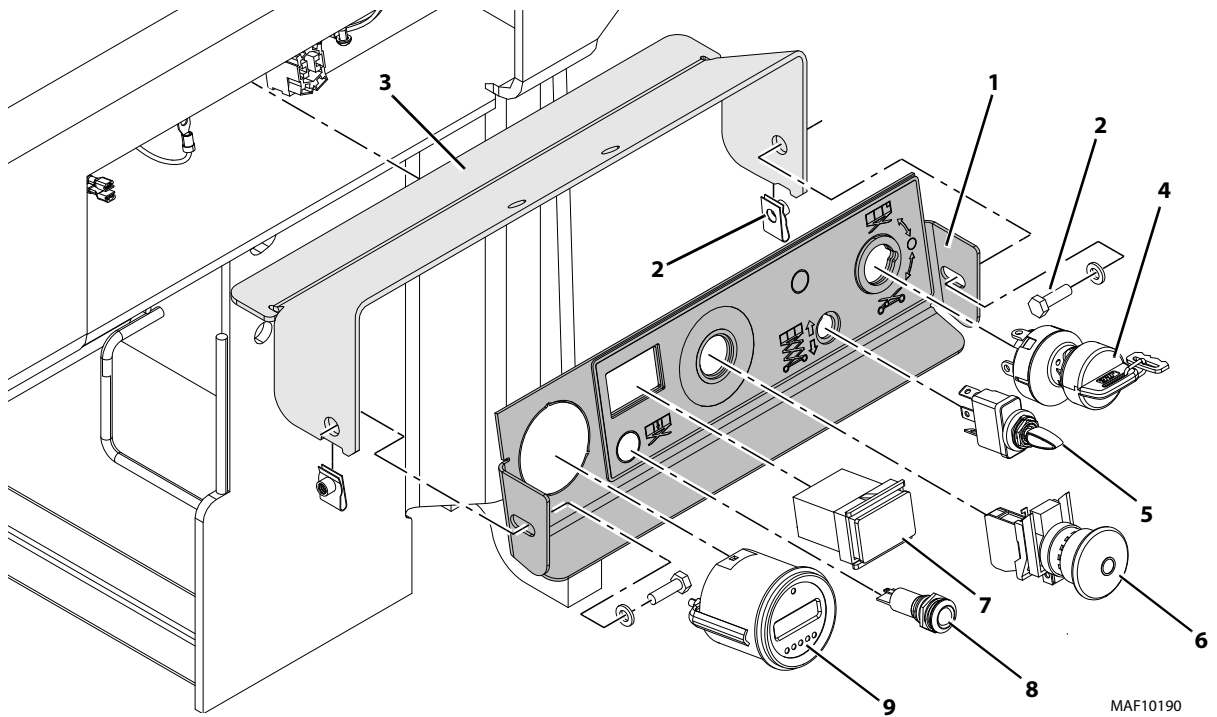

MAF10190

Figure 3-11. Ground Control Station Removal

- | | |
|--|--|
| 1. Ground Control Housing | 6. Emergency Stop Switch |
| 2. Attach Bolt, Washer and Tinnerman Nut | 7. Hourmeter |
| 3. Rear Panel Protective Cover | 8. Overload Indicator |
| 4. Platform/OFF/Ground Select Switch | 9. Multi-Display-Indicator (If Equipped) |
| 5. Platform UP/DOWN Switch | |

NOTE: See electrical schematic Section 8 for wiring connections to switches and gauges.

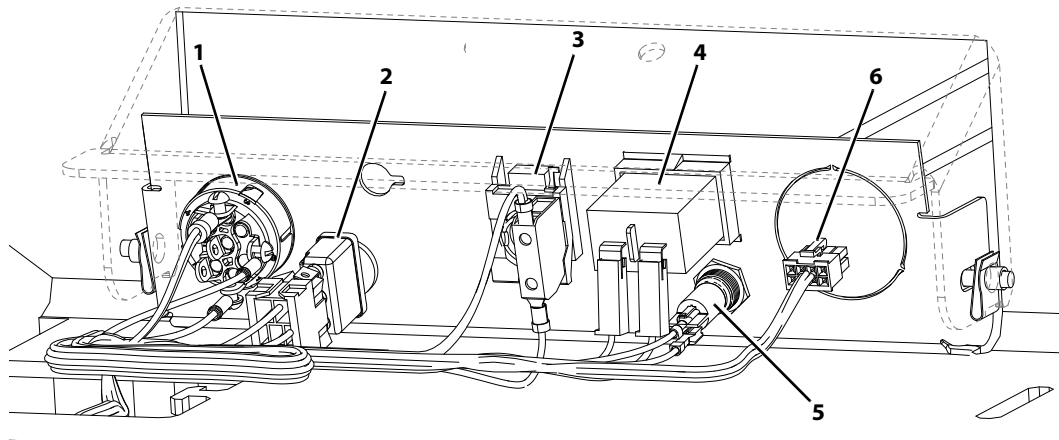

MAF10200

Figure 3-12. Ground Control Station - Rear of Panel

- | | | |
|---------------------------------|--------------------------|--|
| 1. Platform/OFF/Ground Selector | 3. Emergency Stop Switch | 5. Overload Indicator |
| 2. Platform UP/DOWN Switch | 4. Hour Meter | 6. Multi-Display-Indicator (If Equipped) |

3.9 PLATFORM CONTROL STATION

NOTICE

POWER MACHINE DOWN AT THE GROUND CONTROL STATION BEFORE DISCONNECTING THE PLATFORM CONTROL STATION.

Overview of Control Station Components

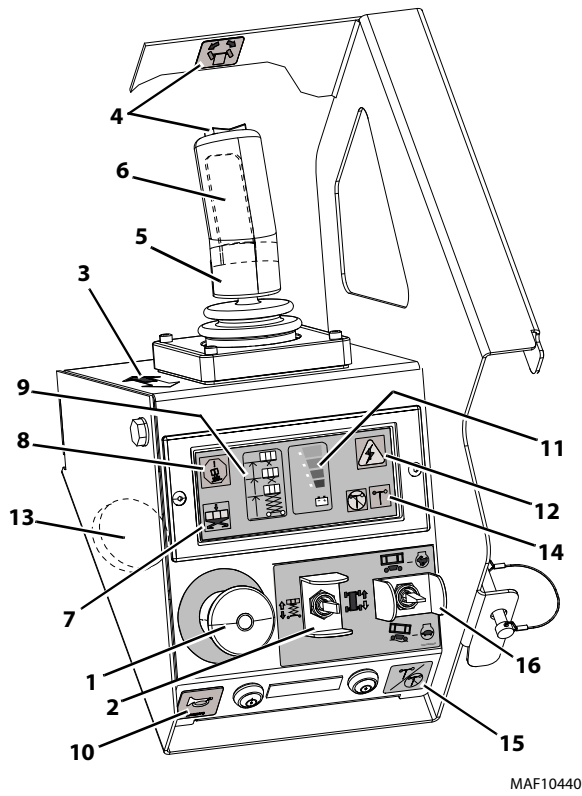

Figure 3-13. Platform Control Station Components (R3246) - External

- | | |
|---|---|
| 1. Emergency Stop Switch | 10. Horn Button |
| 2. Lift/Drive Select Switch | 11. Battery Discharge Indicator |
| 3. Black/White Directional Arrow | 12. System Fault Indicator |
| 4. Steer Switch and Decal | 13. Alarm (not shown, located on bottom of box) |
| 5. Controller | 14. Alarm (not shown, located on bottom of box) |
| 6. Trigger Switch (on front of controller) | 15. Alarm (not shown, located on bottom of box) |
| 7. Overload Indicator (LSS) | 16. Speed Select Switch |
| 8. Tilt Indicator | |
| 9. Variable Tilt - Platform Restricted Height Indicator | |

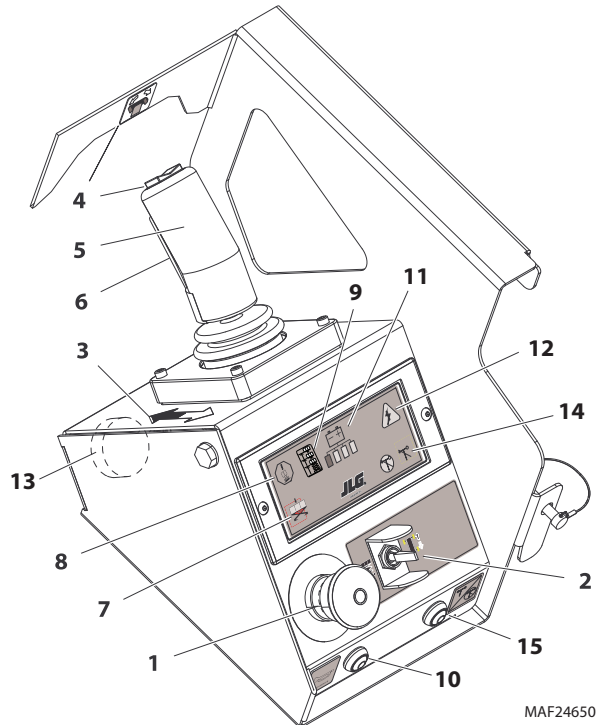

Figure 3-14. Platform Control Station Components (R2632) - External

- | | |
|---|--|
| 1. Emergency Stop Switch | 10. Horn Button |
| 2. Lift/Drive Select Switch | 11. Battery Charge Indicator |
| 3. Black/White Directional Arrow | 12. System Fault Indicator |
| 4. Steer Control Switch and Decal | 13. Alarm (not shown, located on bottom of box) |
| 5. Controller | 14. Indoor/Outdoor Operation Indicator |
| 6. Trigger Switch (on front of controller) | 15. Indoor/Outdoor Operation Mode Switch (All market except AUS) |
| 7. Overload Indicator (LSS) | |
| 8. Tilt Indicator | |
| 9. Variable Tilt - Platform Restricted Height Indicator | |

Installation/Removal

1. Disconnect the platform control station harness at the round connector on front the control station.
2. Remove the pin securing the control station to the platform station mount, lift up and swing tab out of slot in mount, remove control station from the machine.
3. To install, reverse steps 1 and 2 above.

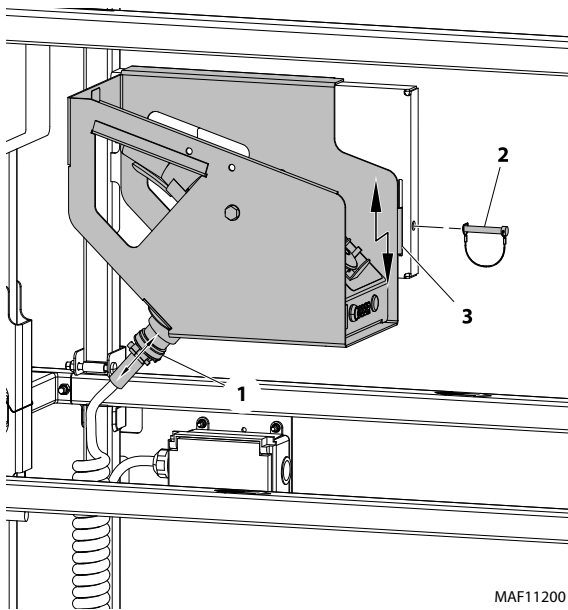

Figure 3-15. Platform Control Station Installation

- | | |
|----------------------|--------------------|
| 1. Harness Connector | 3. Lift and Remove |
| 2. Mounting Pin | |

Control Station Disassembly

1. Place the platform control station assembly on a suitable work bench.
2. Remove the main body from the mount, by removing bolt, cap-nut and washers (item 1) and the two bolts and washers (item 2) on the bottom of the assembly.

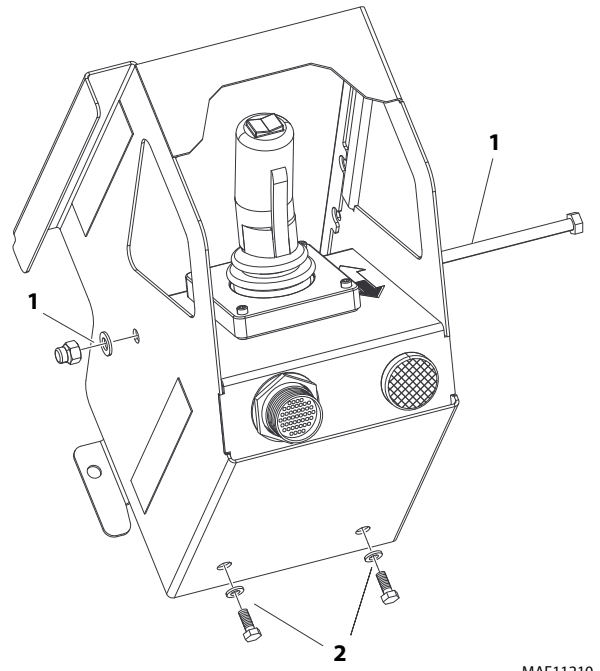
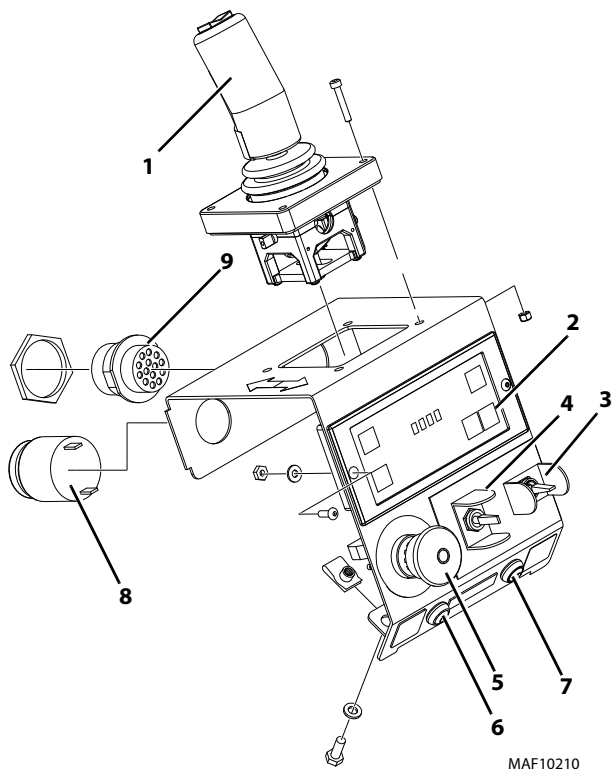

Figure 3-16. Platform Control Station Disassembly

- | | |
|---|---|
| 1. Through Bolt, Cap-nut | 2. Rear Edge Bolts and Nuts and Washers |
| 3. To install, reverse steps 1 and 2 above. | |



MAF10210

Figure 3-17. Platform Control Station Components (R3246) - Internal

- | | |
|---|---------------------------|
| 1. Drive, Lift and Steer Joystick Control | 6. Horn Button Switch |
| 2. Indicator Panel Module | 7. Overload Indicator |
| 3. Speed Select Switch | 8. Alarm |
| 4. Lift/Drive Select Switch | 9. Main Harness Connector |
| 5. Emergency Stop Switch | |

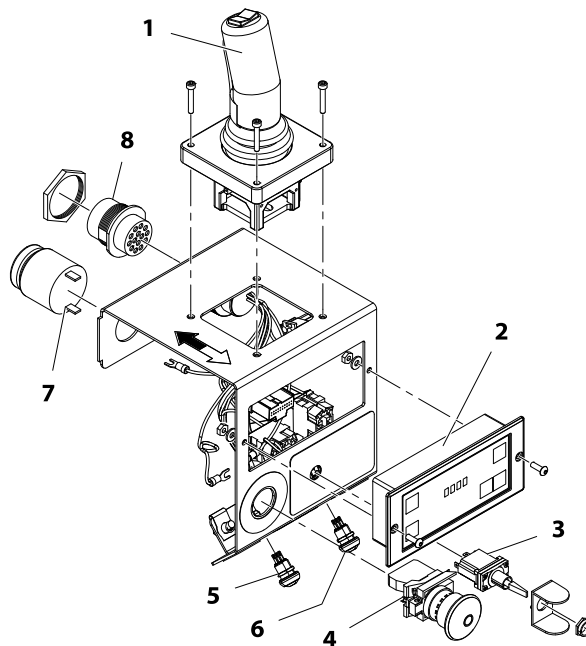

Figure 3-18. Platform Control Station Components (R2632) - Internal

- | | |
|---|---------------------------|
| 1. Drive, Lift and Steer Joystick Control | 5. Horn Button Switch |
| 2. Indicator Panel Module | 6. Overload Indicator |
| 3. Lift/Drive Select Switch | 7. Alarm |
| 4. Emergency Stop Switch | 8. Main Harness Connector |

Joystick Controller

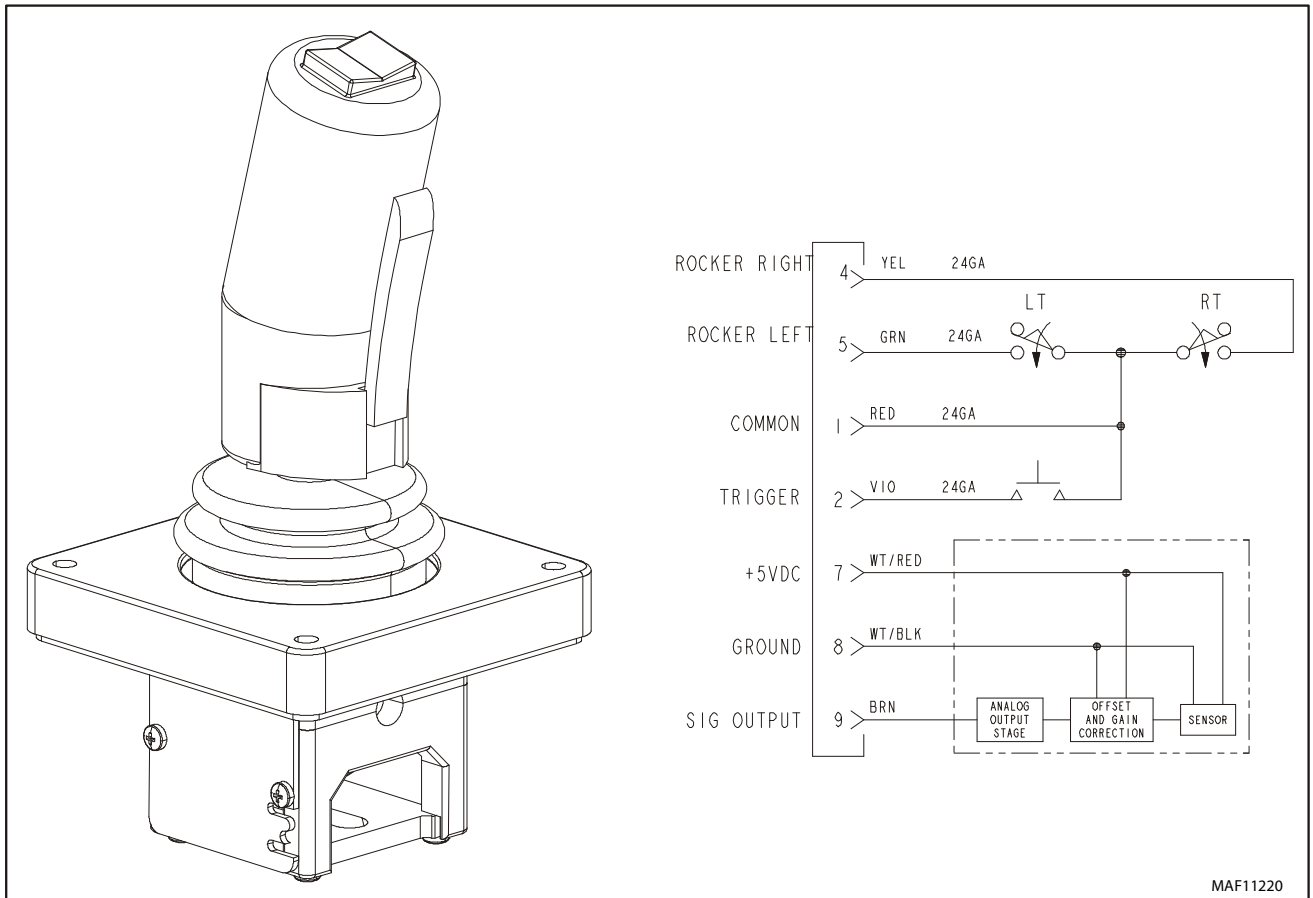

Figure 3-19. Joystick

Table 3-6. Joystick Specifications

Input Voltage	+5 (±0.1)VDC
Current Consumption	10 mA @ 12VDC
Output: Handle Centered	2.5 (±0.1)VDC
Output: Full Positive (Reverse) Deflection	4 (±0.1)VDC
Output: Full Negative (Forward) Deflection	1 (±0.1)VDC

NOTE: For joystick calibration procedure see Section 5.2, Joystick Calibration.

Table 3-7. Connector Chart

CONNECTOR PINOUT		
Term	Color	Function
1	RED	HANDLE COM
2	VIOLET	TRIGGER N.O.
3	--	SPARE
4	YELLOW	ROCKER RT
5	GREEN	ROCKER LT
6	--	SPARE
7	WHITE/RED	+5VDC
8	WHITE/BLACK	GROUND
9	BROWN	SIG OUTPUT

3.10 TILT SENSOR INSTALLATION

The tilt sensor is located inside the right side machine compartment door on mounting plate towards front of machine.

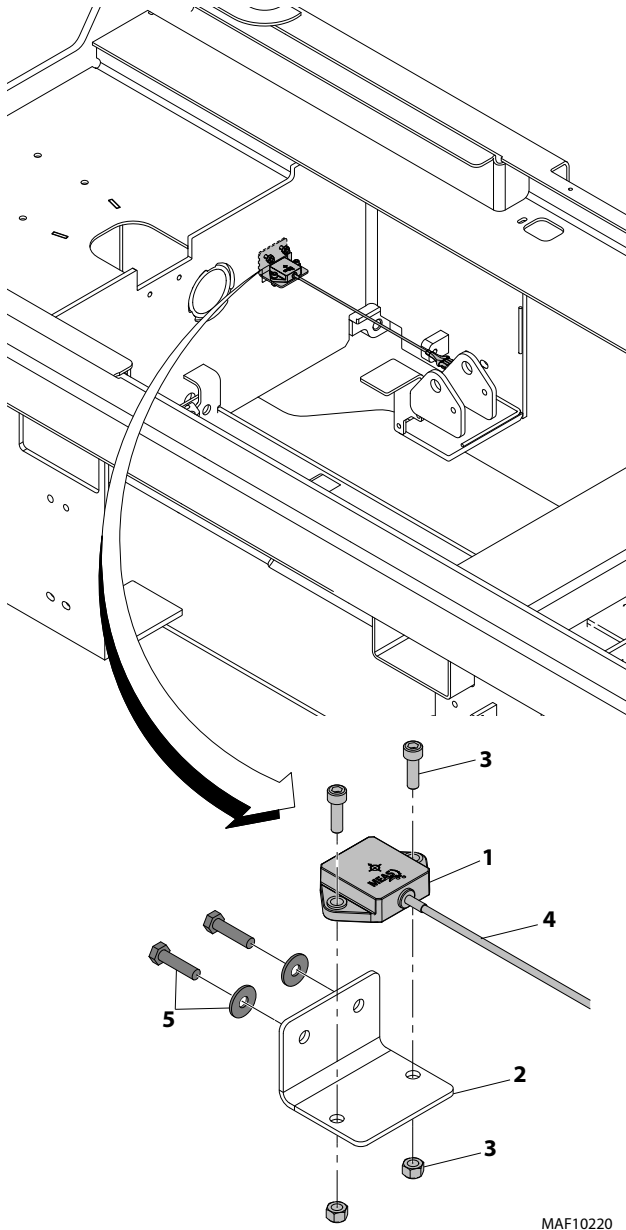

Figure 3-20. Tilt Sensor Installation
(pot-hole bar removed for clarity)

- | | |
|----------------------------------|---|
| 1. Tilt Sensor | 4. Wire Harness Connector |
| 2. Mounting Plate | 5. Mounting Plate Hardware
(Apply Medium Strength Threadlocking Compound to bolts before installation) |
| 3. Tilt Sensor Mounting Hardware | |

Tilt Sensor Removal

1. Open right side compartment door, disconnect the battery power from the machine.
2. Locate the tilt sensor on the frame mounting plate next to the right side compartment door hinge assembly. Unplug the tilt sensor harness connector.
3. Remove two mounting bolts and locknuts attaching the sensor to the mounting plate.
4. Remove two mounting bolts, washer and nuts attaching mounting plate to the base frame.

Tilt Sensor Installation

1. Before mounting the mounting plate, tilt sensor to the base frame, check the mating surfaces of the sensor, mounting plate and base are free from debris or burrs to prevent flush mount.
2. Install mounting plate onto base frame with bolts, washer and nuts.
3. When mounting the tilt sensor onto the mounting plate, mount with the wiring harness pointing to the rear of the machine. Align the two mounting holes of the sensor with the holes of the mounting plate.
4. Secure tilt sensor onto mounting plate with mounting hardware.
5. Plug the wire harness connector into the tilt sensor.
6. Reconnect the battery power to the machine.
7. Start the machine and check tilt sensor calibration with handheld analyzer. See Section 5, JLG Control System for tilt sensor calibration procedure.

Table 3-8. Tilt Sensor Wiring Pin Assignment

Pin	Function	Wire Color	Description
1	Vcc	WHT	+8To 30V (32V Max)
2	GND	YEL	Ground
3	CANH	GRN	CAN HIGH LINE
4	CANL	BRN	CAN LOW LINE

3.11 ARM ANGLE SENSOR

This machine is equipped with a scissor arm rotary angle sensor switch. This sensor communicates with the machine control module to determine platform height.

On LSS equipped machines this sensor works in tandem with the lift cylinder pressure switch to accurately determine platform load for any given platform height.

There is no adjustment to the angle sensor switch, just install in the proper orientation and calibrate. For location of arm angle sensor refer below illustration.

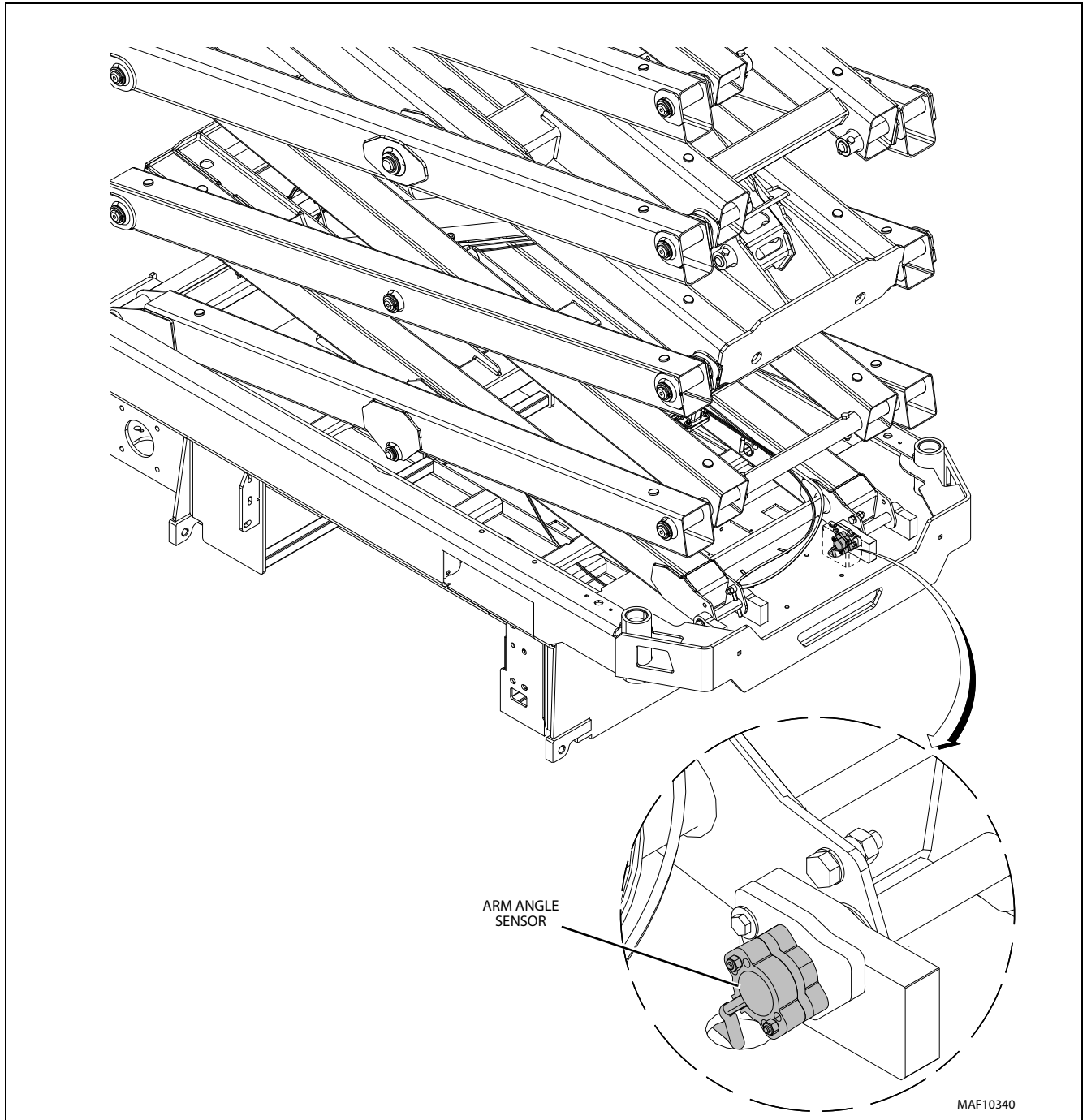

Arm Angle Sensor Installation

(See Figure 3-21.)

1. Install angle sensor to mounting bracket with wire lead pointing away from bend in mounting bracket as shown in Figure 1. Secure with bolts and locknuts.
2. Insert key into slot in the scissor arm pin with the narrow tab end pointing away from the pin as shown in figure 2.
3. Insert narrow end of key into slot of angle sensor.
4. With the Angle sensor and bracket oriented as shown in Figure 1, carefully slide keeper pin into sensor pin from other end. Secure keeper pin with mounting hardware.
5. Carefully rotate sensor and bracket to load sensor spring until holes in the bracket line up with slots on frame mounting plate Figure 2. Rotation is approximately 120°, or 1/3 of a turn.
6. Secure mounting bracket to frame with bolts, locknuts and washers. Care should be taken to maintain alignment between rotating sensor slot and key so they can freely rotate together when arm stack is elevated. Secure all hardware.
7. Calibrate the sensor after installation. (See Section 5.4, Rotary Angle Sensor Calibration).

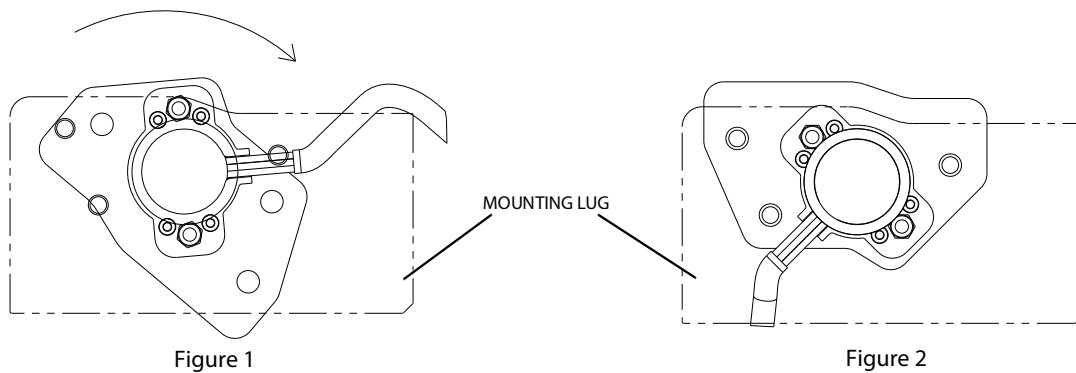
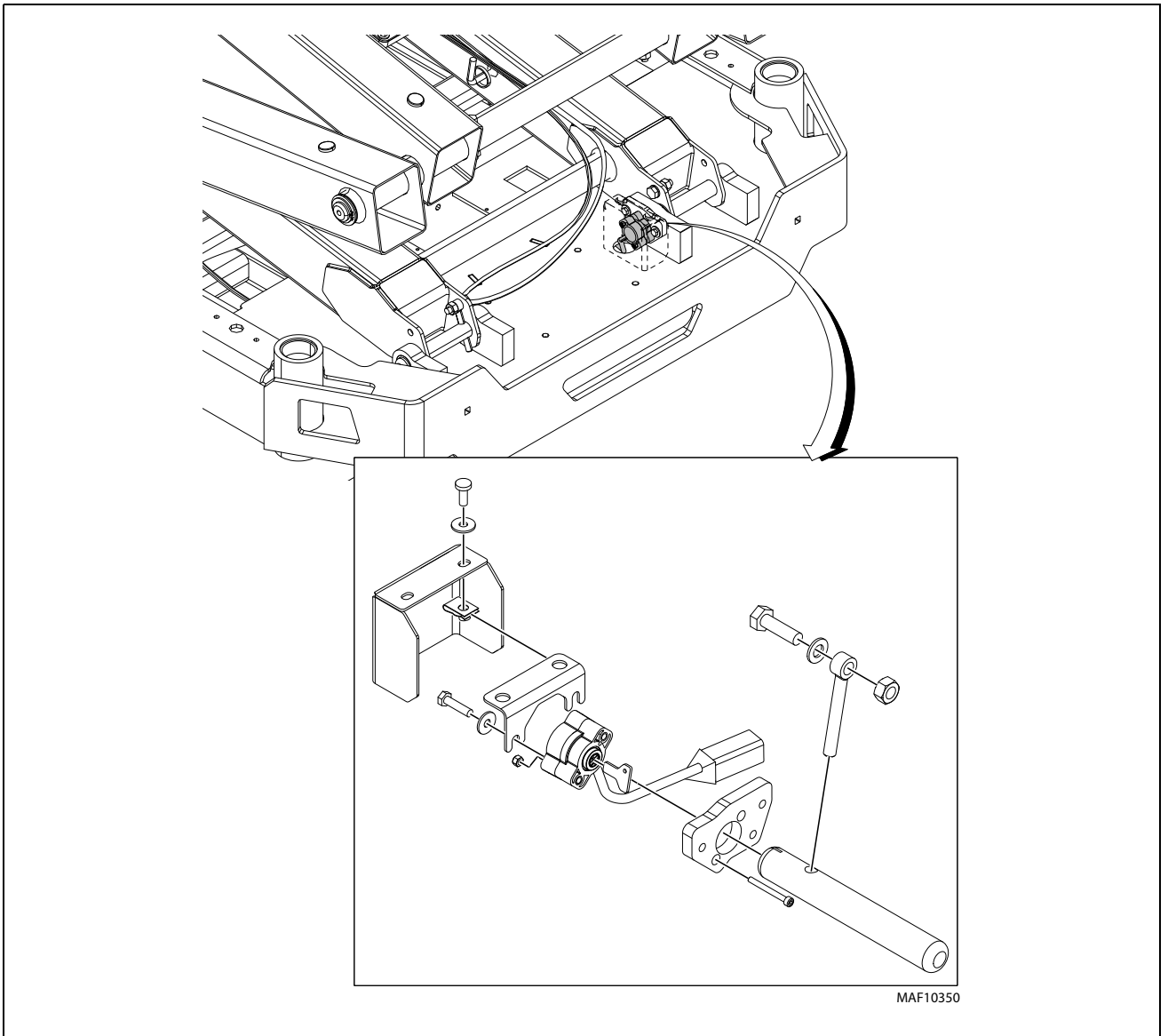
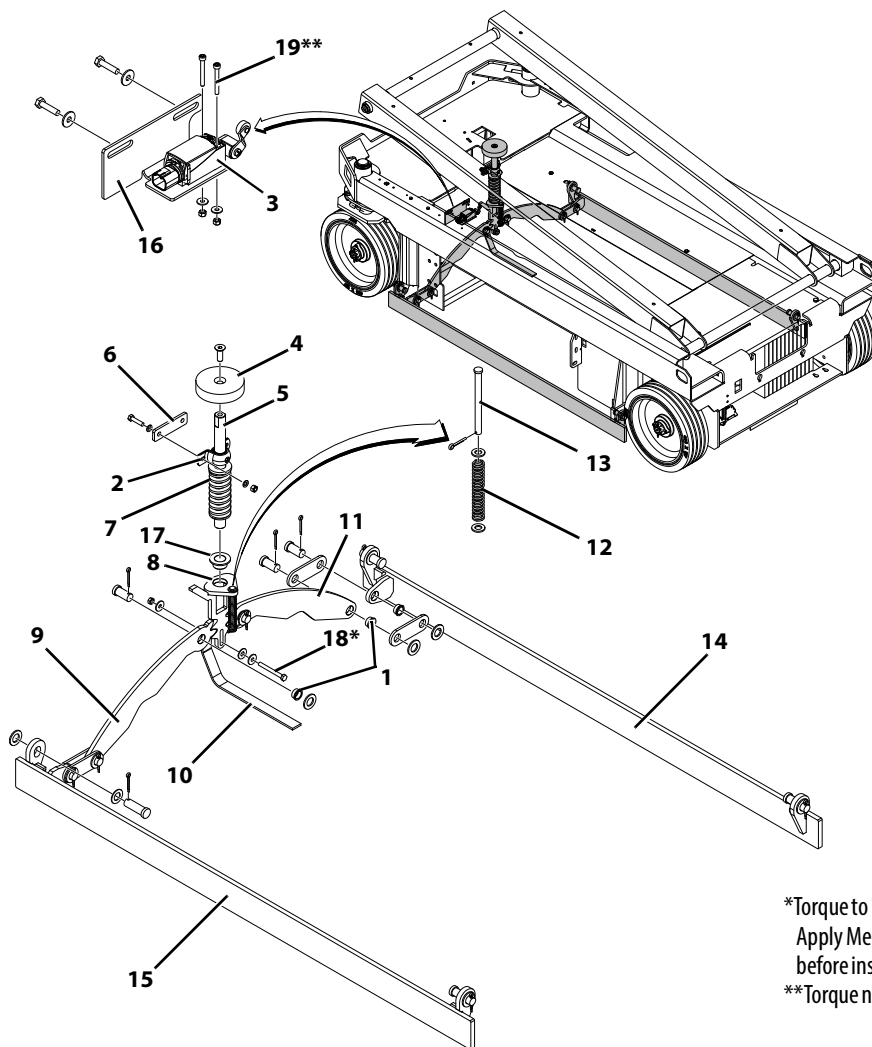

Figure 3-21. Angle Sensor Orientation

MAF10420



3.12 POTHOLE PROTECTION SYSTEM COMPONENTS



- 1. Bearing
- 2. Bearing Bracket
- 3. Limit Switch
- 4. Pad
- 5. Upper Actuator
- 6. Mounting Plate
- 7. Spring
- 8. Lower Actuator
- 9. Pinion Plate
- 10. Anti-Static Strap
- 11. Link
- 12. Spring
- 13. Pin
- 14. Bar (RH)
- 15. Bar (LH)
- 16. Sensor Mounting Plate
- 17. Bearing
- 18. Bolt
- 19. Limit Switch Mounting Screw

*Torque to 11.67-14.75 ft. lbs. (16-20 Nm)
 Apply Medium Strength Threadlocking Compound to bolt
 before installation
 **Torque not more than 2.58 ft. lbs. (3.5 Nm)

MAF10400

Figure 3-22. PotHole Protection Assembly (R3246)

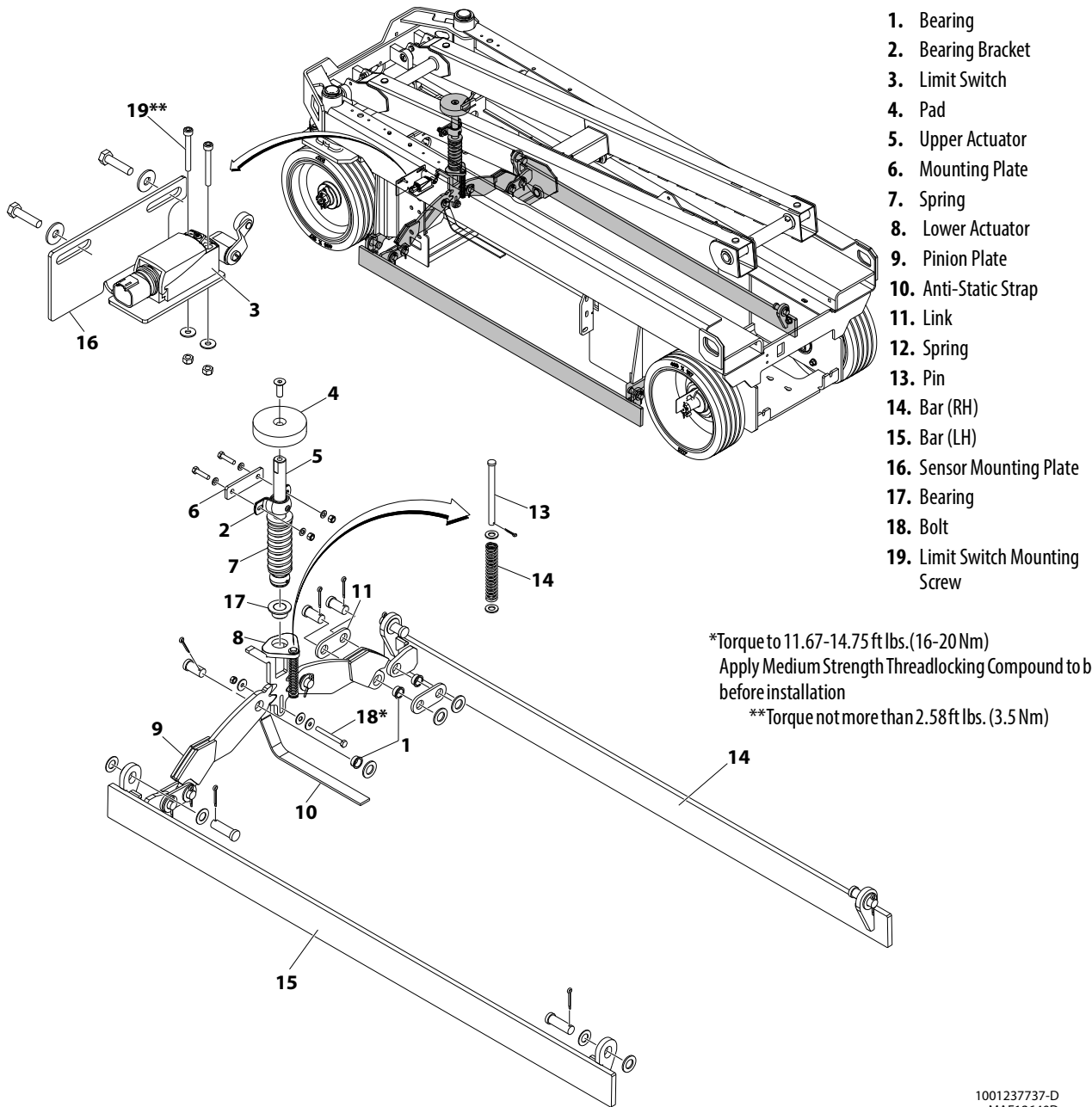

1. Bearing
2. Bearing Bracket
3. Limit Switch
4. Pad
5. Upper Actuator
6. Mounting Plate
7. Spring
8. Lower Actuator
9. Pinion Plate
10. Anti-Static Strap
11. Link
12. Spring
13. Pin
14. Bar (RH)
15. Bar (LH)
16. Sensor Mounting Plate
17. Bearing
18. Bolt
19. Limit Switch Mounting Screw

*Torque to 11.67-14.75 ft lbs.(16-20 Nm)
Apply Medium Strength Threadlocking Compound to bolt
before installation

**Torque not more than 2.58ft lbs.(3.5 Nm)

Figure 3-23. PotHole Protection Assembly (R2632)

1001237737-D
MAF12640D

WARNING

NEVER WORK UNDER AN ELEVATED PLATFORM UNTIL IT HAS BEEN RESTRAINED FROM MOVEMENT WITH SAFETY PROPS, BLOCKING, OR OVERHEAD SLING.

1. Install flange bearings into the frame holes with the flange side facing inside of frame against Pot-Hole bar hinge.
2. PHP Bearing Adjustment - If reassembling or replacing PHP components, PHP bars may not store at same height due to manufacturing tolerances of parts. Adjustment may be needed after assembly:
 - a. Completely lower the platform and compress the actuator assembly to raise the PHP bars, check to see if only one PHP bar is raised against the frame.
 - b. If Yes, elevate the platform to release the actuator assembly and deploy the PHP bars. The actuator bearing bracket (2) allows for some side to side adjustment, mark the current position of the actuator bearing bracket (2) on the frame.
 - c. Loosen and move the actuator bearing bracket slightly towards the PHP bar that will not raise completely, and re-tighten bracket down.
 - d. Compress the actuator assembly again to stow the PHP bars and check bar ground clearance. Repeat steps (a) through (c) above until both PHP bars achieve maximum ground clearance. (See Ground Clearance - Section 1.1, Operating Specification).
3. Do not tighten limit switch mounting screws beyond 2.58 ft lbs. (3.5 Nm).
4. PHP Limit Switch Adjustment - When the platform is raised and PHP bars fully DOWN, adjust the switch until it lightly contacts the ramp on the lower actuator.

3.13 STEER AND SPINDLE ASSEMBLY COMPONENTS

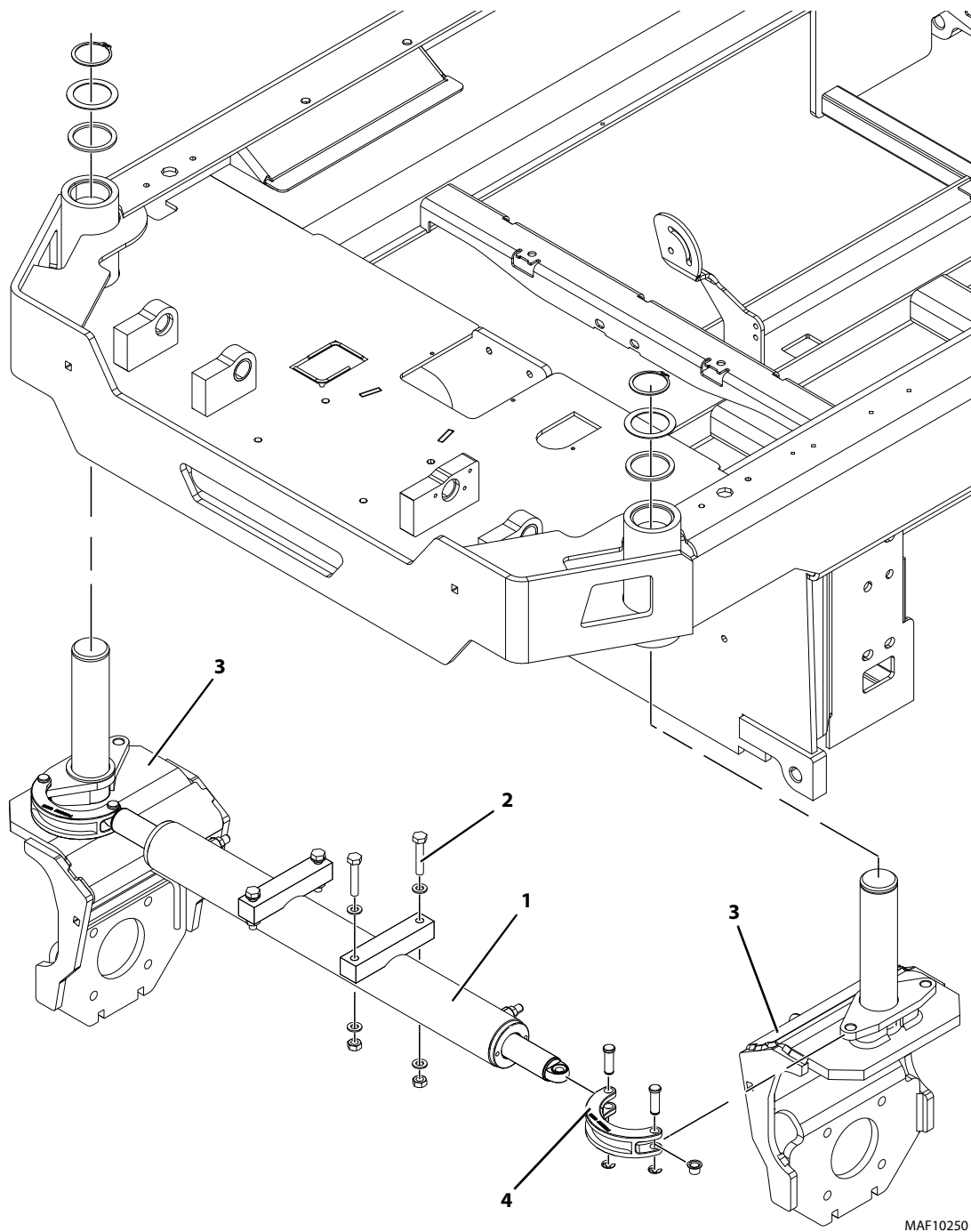

MAF10250

Figure 3-24. Steer and Spindle Assembly Installation (R3246)

1. Mount steer cylinder with ports facing the rear of the machine.
2. Apply Medium Strength Threadlocking Compound to bolt threads before tightening.
3. Spindle weldment interchangeable with either side.
4. Steering Lug

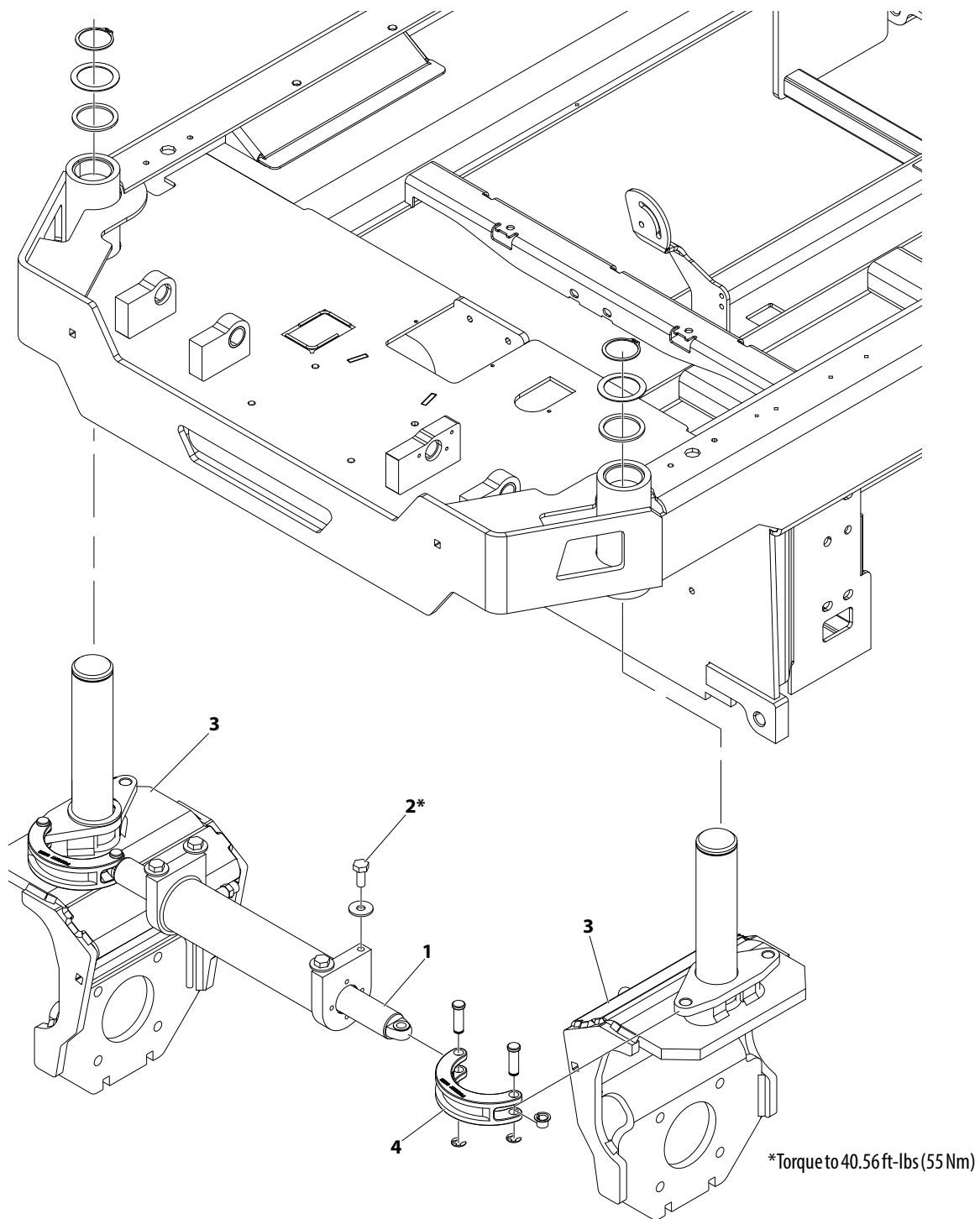

MAF12680A

Figure 3-25. Steer and Spindle Assembly Installation (R2632)

- | | |
|--|--|
| <ol style="list-style-type: none"> 1. Mount steer cylinder with ports facing the rear of the machine. 2. Apply Medium Strength Threadlocking Compound to bolt threads before tightening. | <ol style="list-style-type: none"> 3. Spindle weldment interchangeable with either side. 4. Steering Lug |
|--|--|

Drive Motor Covers Installation - Option

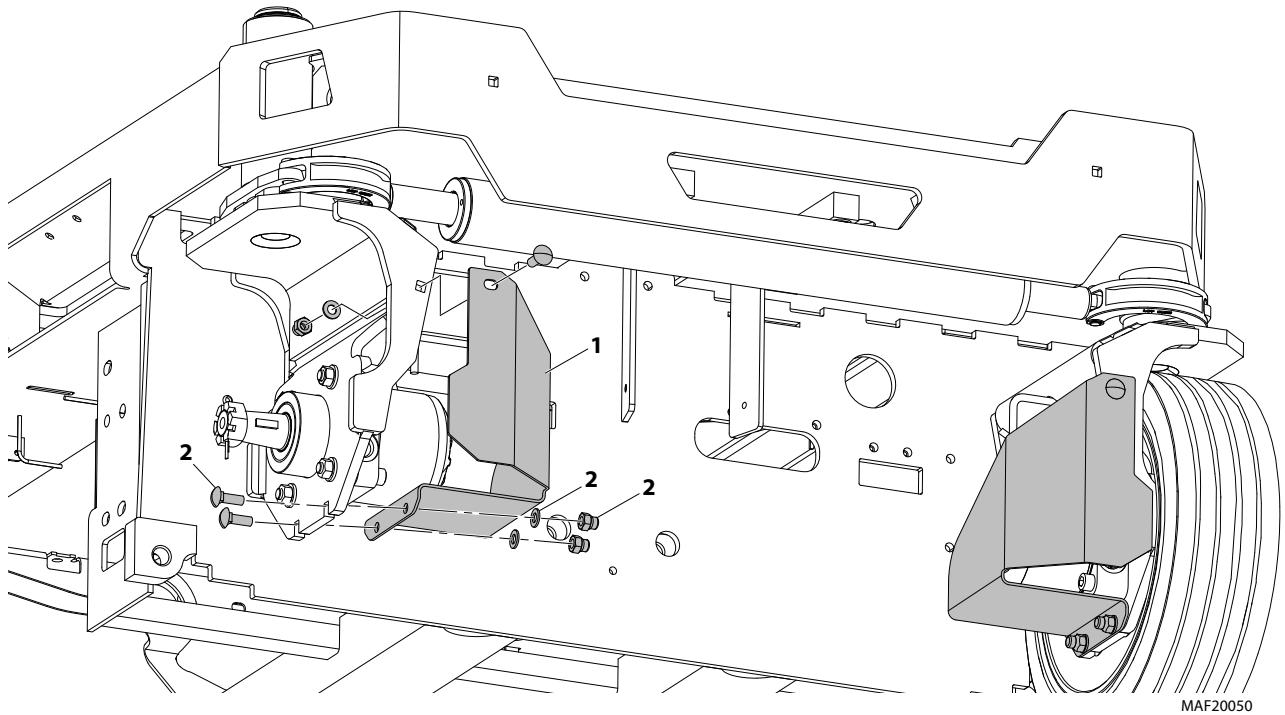

Figure 3-26. Drive Motor Cover Installation - Option

NOTE: Cover installation same for both sides.

1. Drive Motor Cover

2. Cover carriage bolts, nuts, and washers

Tire Wear and Damage

The tire and rim assemblies installed on machines have been approved by the tire manufacturer for applications in which those products are intended to be used. The tire and rims installed on each product model have been designed for stability requirements, which consist of track width, tire compound, and load capacity. Tire changes such as rim width, centerpiece location, larger or smaller diameter, tire compound, etc., without written manufacturers approval, could result in an unsafe condition regarding stability.

The tires and rims installed on machines are to be inspected daily as part of the daily walk-around inspection. JLG requires that the daily walk-around inspection be performed at each operator change during a shift and at each shift change.

Wheel and Tire Replacement

JLG recommends that any replacement tire be the same size and brand as originally installed on the machine or offered by JLG as an approved replacement. Please refer to the JLG Parts Manual for the part number of the approved tires for a particular machine model.

If any of the following is discovered during tire inspection, measures must be taken to remove the JLG product from service immediately. Arrangements must be made for replacement of the tire(s) or tire assembly(s). Both tires/wheels on the same axle must be replaced:

- If the overall diameter of the tire is less than one of the following:

406 x 127 Tire – 15.55 in. (395 mm) minimum

- If any uneven wear is discovered.

A tire with significant damage in the tread area or sidewall requires immediate evaluation before placing the machine into service. If a cut, tear, chunk, or other discrepancy exceeds any one or more of the following dimensions, the tire must be replaced:

3.0 in. (76 mm) long
 0.75 in. (19 mm) wide
 0.75 in. (19 mm) deep

- If the metal wheel is visible at any point through the tread area of the tire.
- If more than one discrepancy exists in any quadrant of the wheel (within 90 degrees of one another).

Wheel Installation

It is extremely important to apply and maintain proper wheel mounting torque.

⚠ WARNING

WHEEL SLOTTED NUTS MUST BE INSTALLED AND MAINTAINED AT THE PROPER TORQUE TO PREVENT LOOSE WHEELS, A BROKEN NUT, AND POSSIBLE SEPARATION OF WHEEL FROM THE AXLE.

Tighten the slotted nuts to the proper torque to prevent wheels from coming loose. Use a torque wrench to tighten the slotted nuts. The proper procedure for attaching wheels is as follows:

1. If not already installed, install shaft key (5) to shaft and align with wheel keyway, install wheel and hub (3) onto tapered shaft (4).
2. Start slotted nut (1) by hand to prevent cross threading. DO NOT use a lubricant on threads or nut.
3. Torque the slotted nut to 150 ft. lb. (203 Nm).
4. Install cotter pin (2), if hole in slots do not align with cotter pin hole on the tapered shaft, continue to turn nut clockwise to align nut with hole. Do not loosen to align hole.

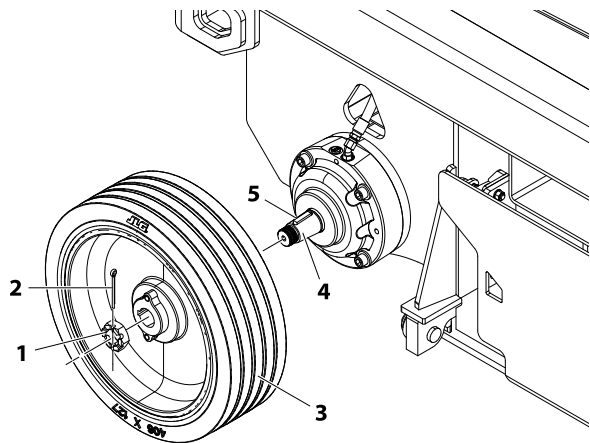

Figure 3-27. Wheel Installation

- | | |
|---------------------------|------------------|
| 1. Slotted Nut | 4. Tapered Shaft |
| 2. Cotter Pin | 5. Shaft Key |
| 3. Wheel and Hub Assembly | |

3.14 ARMS AND PLATFORM POSITIONING AND SUPPORT

⚠ WARNING

NEVER WORK UNDER AN ELEVATED PLATFORM UNTIL IT HAS BEEN RESTRAINED FROM MOVEMENT WITH SAFETY PROPS, BLOCKING OR OVERHEAD SLING.

The arm stack can be supported by using an overhead crane, (See Figure 3-28.). If an overhead crane is not available the stack may also be lifted by using a fork-truck using the following instructions:

1. With the forks on the fork-truck slid close together, enter from the front of the machine and place the forks on the cross tube of the second arm assembly below the platform.
2. Slowly lift the arm stack with the fork-truck while the manual descent valve is being engaged (this allows the oil to drain back into the tank).
3. Place machine on safety prop and leave the fork truck in place.
4. At this point the lift cylinder removal may begin (Refer to Section 4.13, Lift Cylinder Removal Installation).

If removal of the platform becomes necessary use the above procedure to stabilize the platform for pin and platform removal.

3.15 PLATFORM REMOVAL

1. Support the platform using an overhead crane with straps capable of lifting at least 500 lb (227 kg) (See Figure 3-28.).
2. Disconnect and remove the platform control station and wiring harness at the platform. Disconnect AC receptacle cable if applicable. Route the cables out through the hole at the right-rear of the platform to free platform of any constraints when lifting.
3. Remove hardware securing pin to the slide block. Carefully remove the four pin attaching platform to the arm stack.
4. Remove hardware securing pin to the centering link plate at bottom side of platform. Carefully remove the pin attaching arm attach link to centering link plate of platform.
5. Lift the platform from the arm stack and set aside.

NOTE: *When attaching platform back onto scissor arm assembly, follow removal procedures in reverse order.*

3.16 SCISSOR ARMS REMOVAL

1. Remove platform (refer to Section 3.15, Platform Removal).
2. Disconnect all wiring and cables attached to scissor arm assembly.
3. The scissor arms can be removed as a complete unit or individually.

Removing Scissor Arm Assembly as a Complete Unit

1. Remove the rotary angle sensor.
2. Remove the ladder from the frame.
3. Remove hardware securing pin attaching arm link to base frame. Carefully remove pin attaching arm link to base frame.
4. Place two straps around each end of the entire scissor arm assembly. Using an overhead crane, slowly and carefully move the arm stack backwards so that slide blocks at rear of machine slide out the rear of the slide channel on the frame.

NOTE: *Overhead crane and straps must be capable of lifting at least 2000 lb (907 kg).*

5. Once slide blocks are clear of machine, the scissor stack can be moved to a more desirable location for further arm disassembly.

Removing/Installing Scissor Arms Individually

See Figure 3-30. and Figure 3-31.

1. If reusing the pins, number each pin and journal before removing, so the pin can be reinstalled back in same location. Odd numbers on one side and even numbers on other side.
2. With the platform removed, start with the top arms (closest to platform).
3. Secure each arm section being removed using an overhead crane with suitable lifting straps.
4. Remove the bolts securing the connecting pins in place.
5. Remove the pins from the arms.
6. Remove the arm section from the machine using the overhead crane.
7. Repeat previous steps for remaining arm sections.

NOTE: *When attaching scissor arm assembly back onto frame, follow removal procedures in reverse order.*

Self locking fasteners, such as nylon insert and thread deforming locknuts, are not intended to be reinstalled after removal. Always use new replacement hardware when installing locking fasteners.

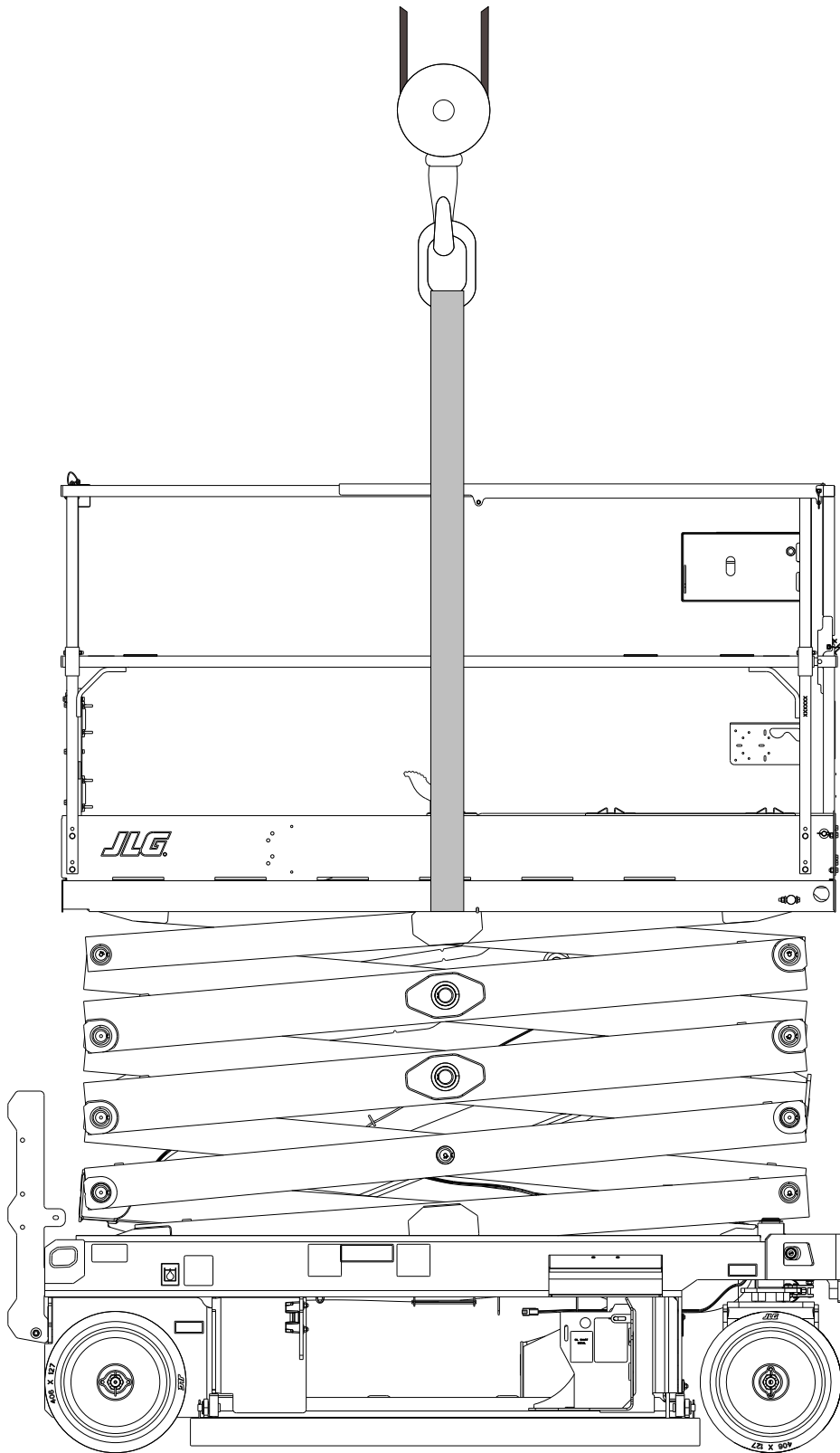

Figure 3-28. Arms and Platform Positioning with Overhead Support

MAF10270

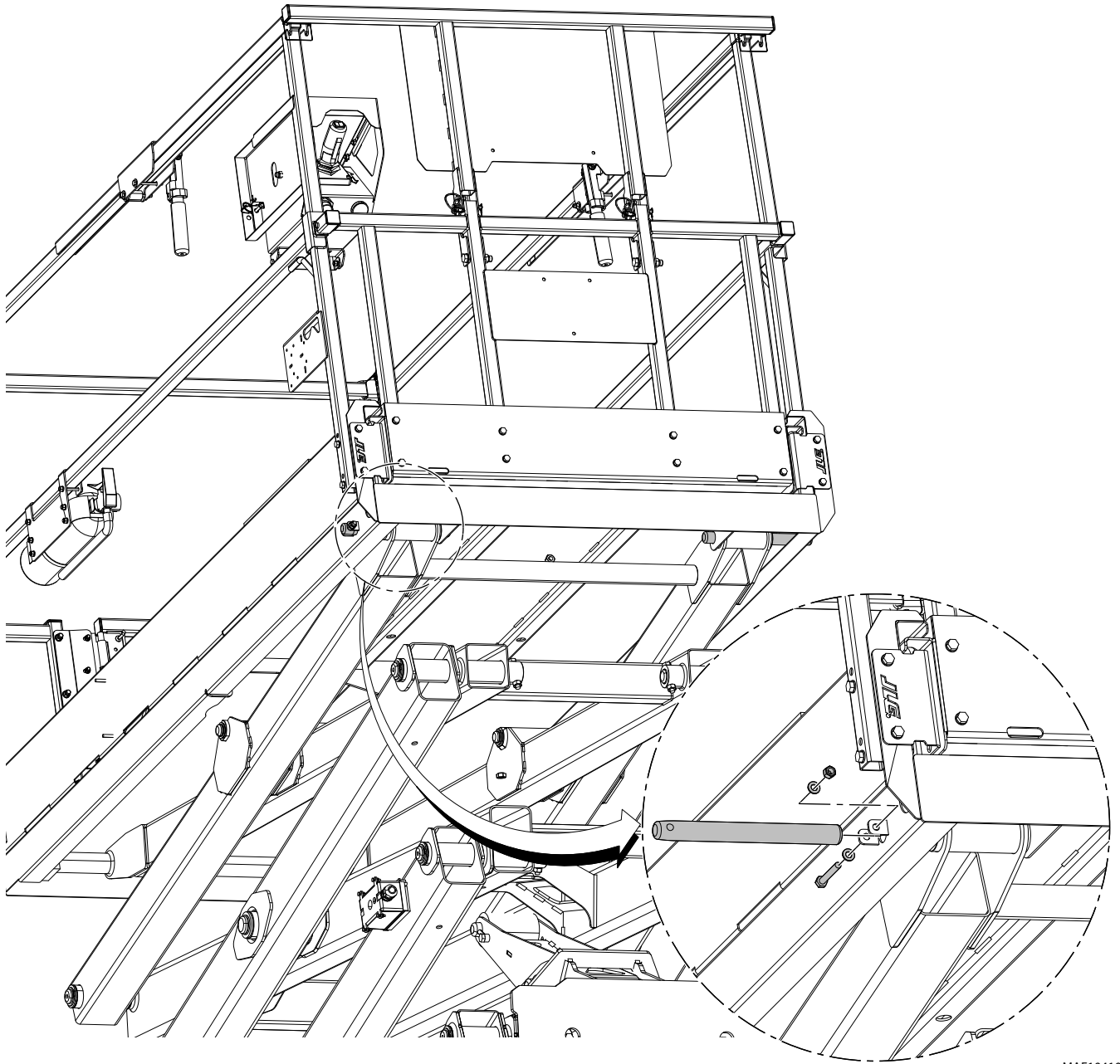

Figure 3-29. Platform Assembly - Installation/Removal

MAF10410

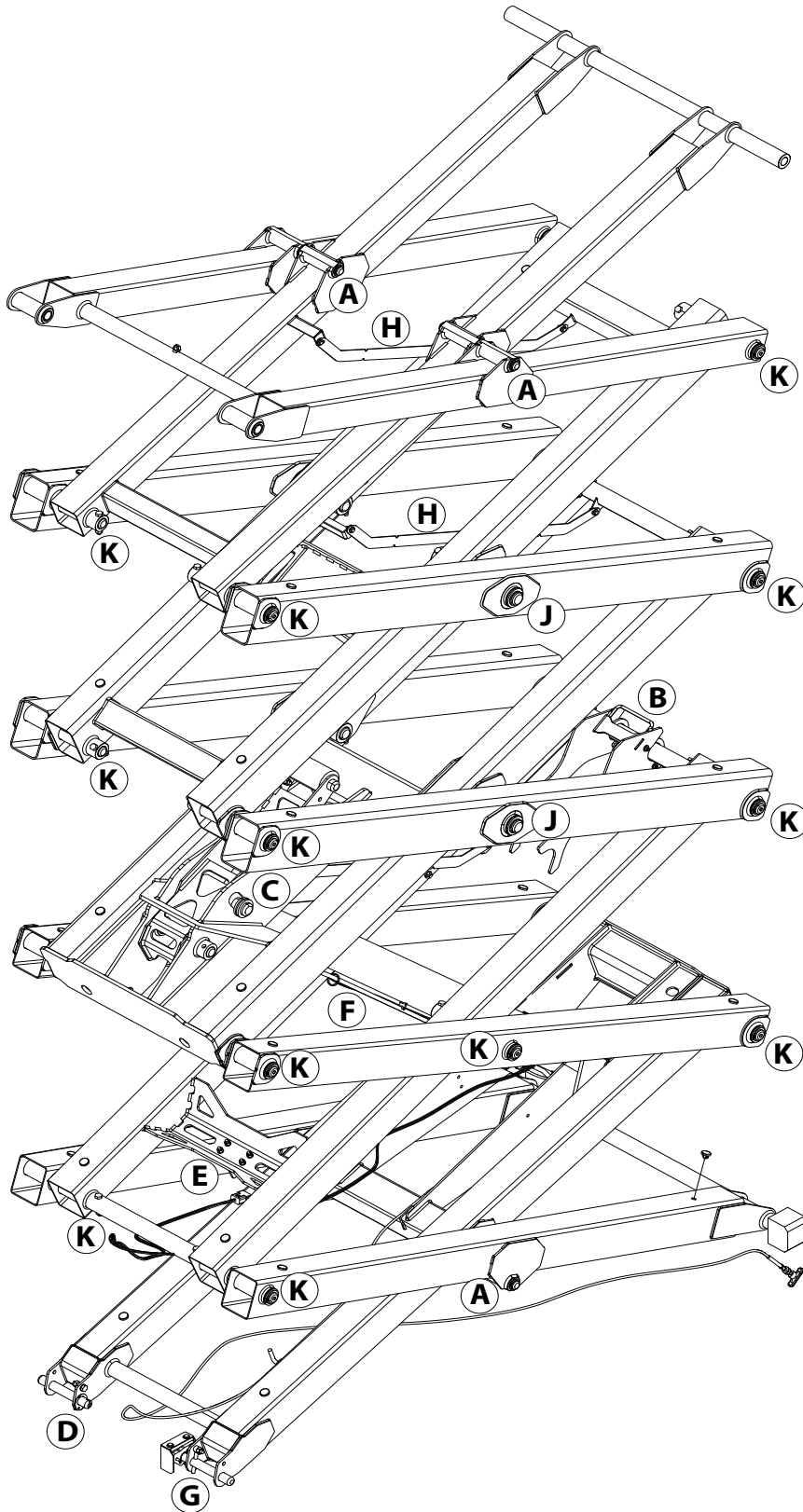

Figure 3-30. Scissor Arm Assembly (R3246)

MAF10090

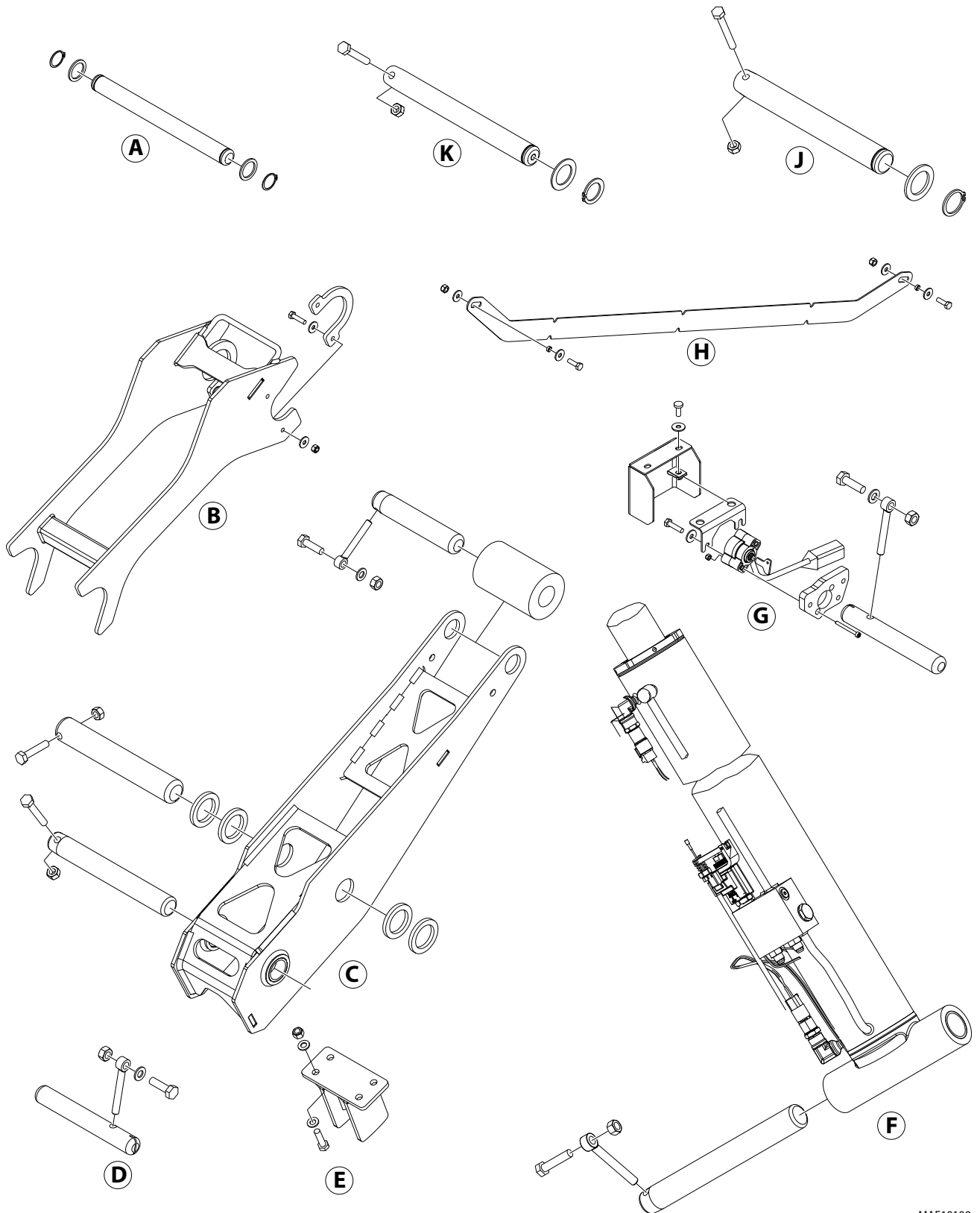
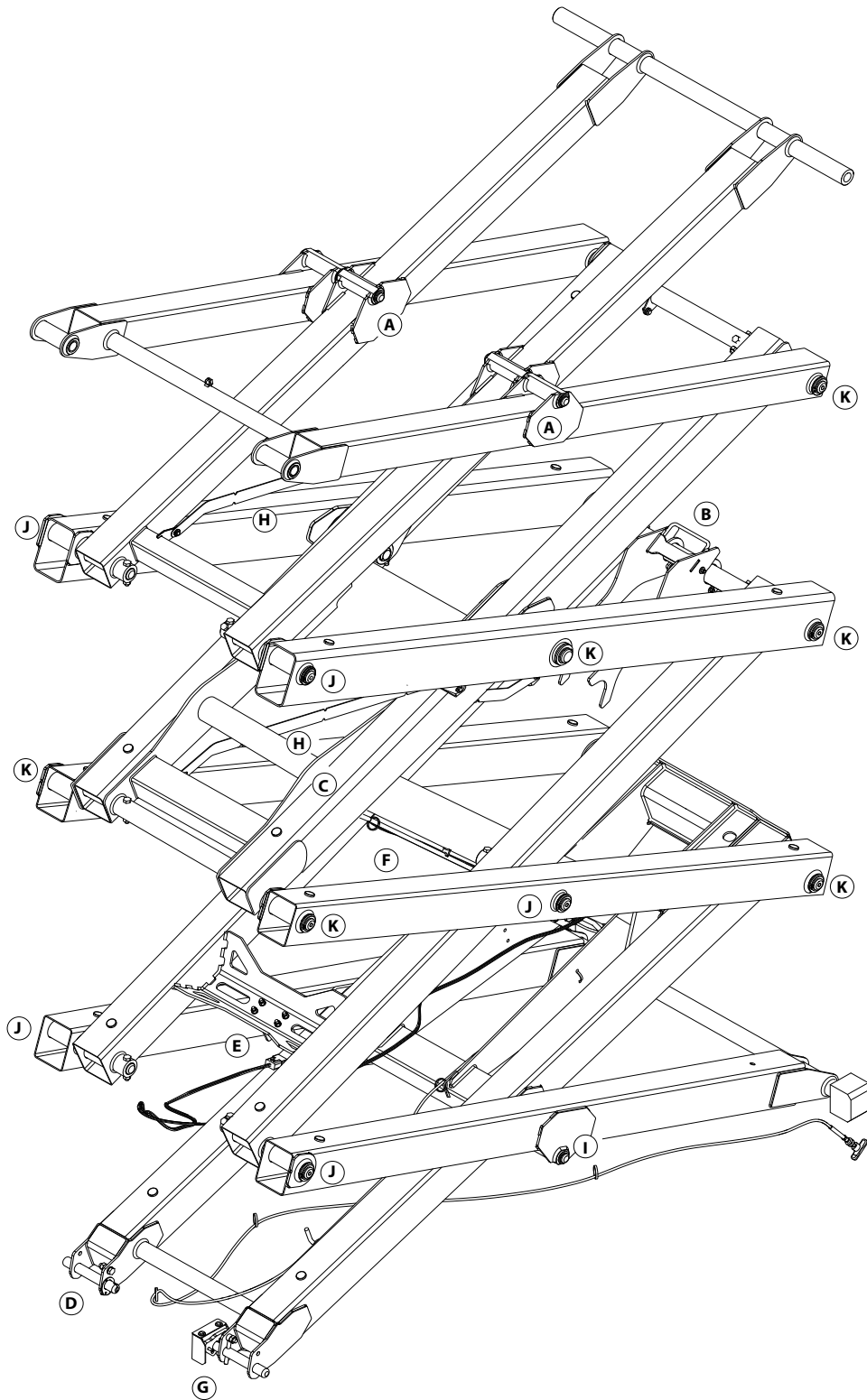

Figure 3-31. Scissor Arm Assembly - Pin Configuration (R3246)

MAF10100



1001370010-G
MAF12650G

Figure 3-32. Scissor Arm Assembly (R2632)

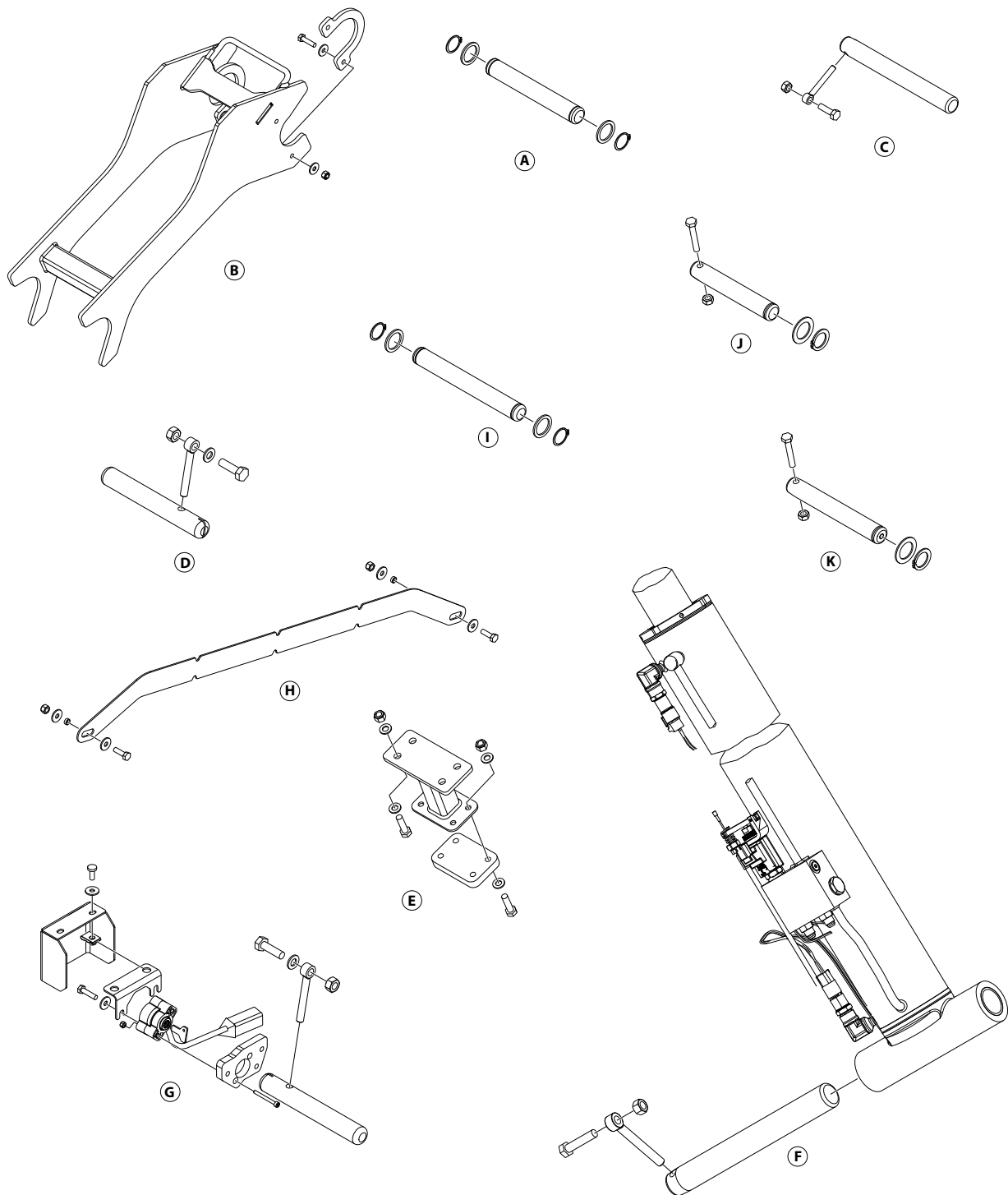

1001370010-G
MAF12660G

Figure 3-33. Scissor Arm Assembly - Pin Configuration (R2632)

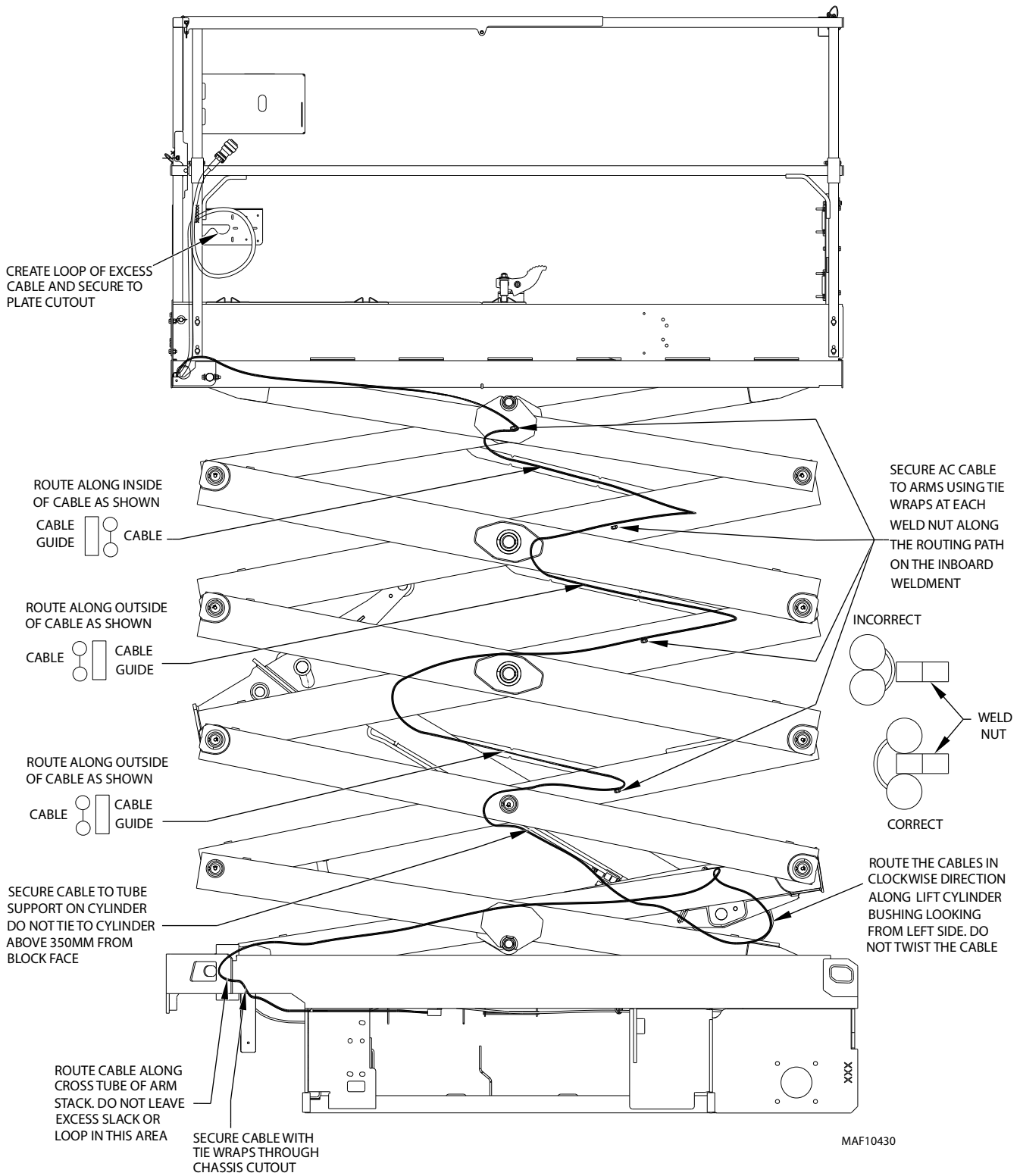

Figure 3-34. Scissor Arm Assembly (R3246) - Cable Routing

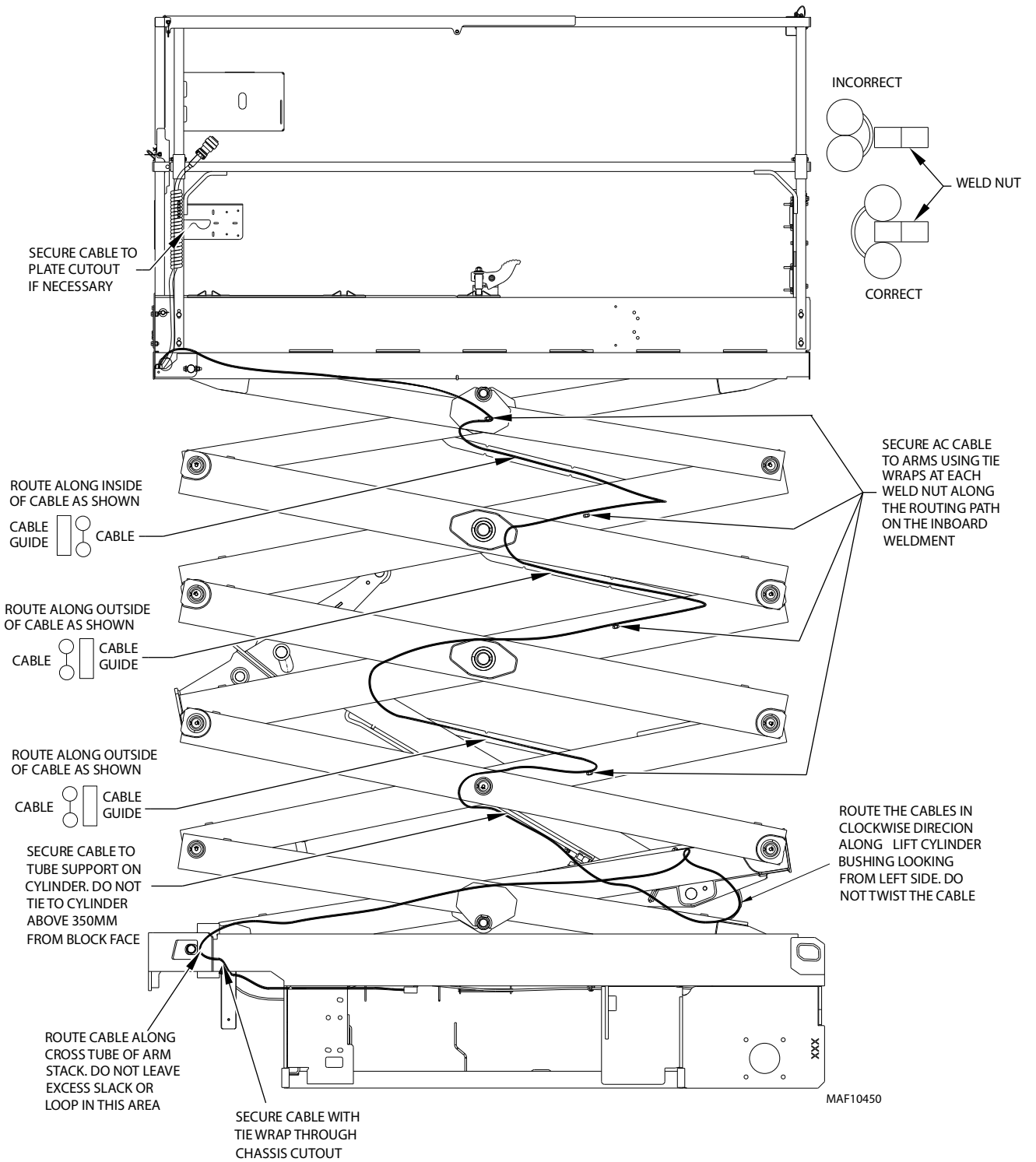

Figure 3-35. Scissor Arm Assembly (R3246) - Cable Routing (Coiled)

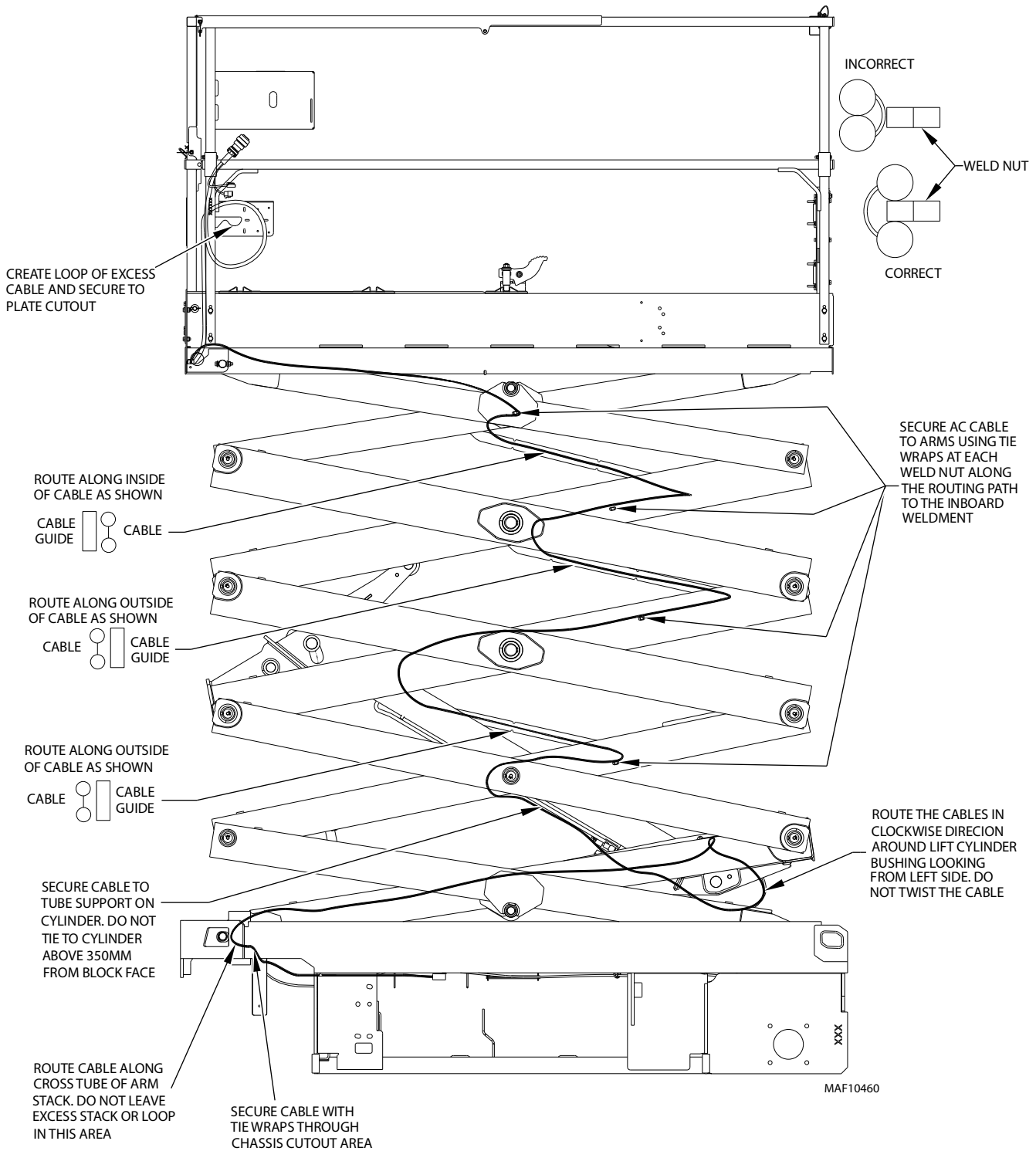

Figure 3-36. Scissor Arm Assembly (R3246) - Cable Routing (With Foot Switch)

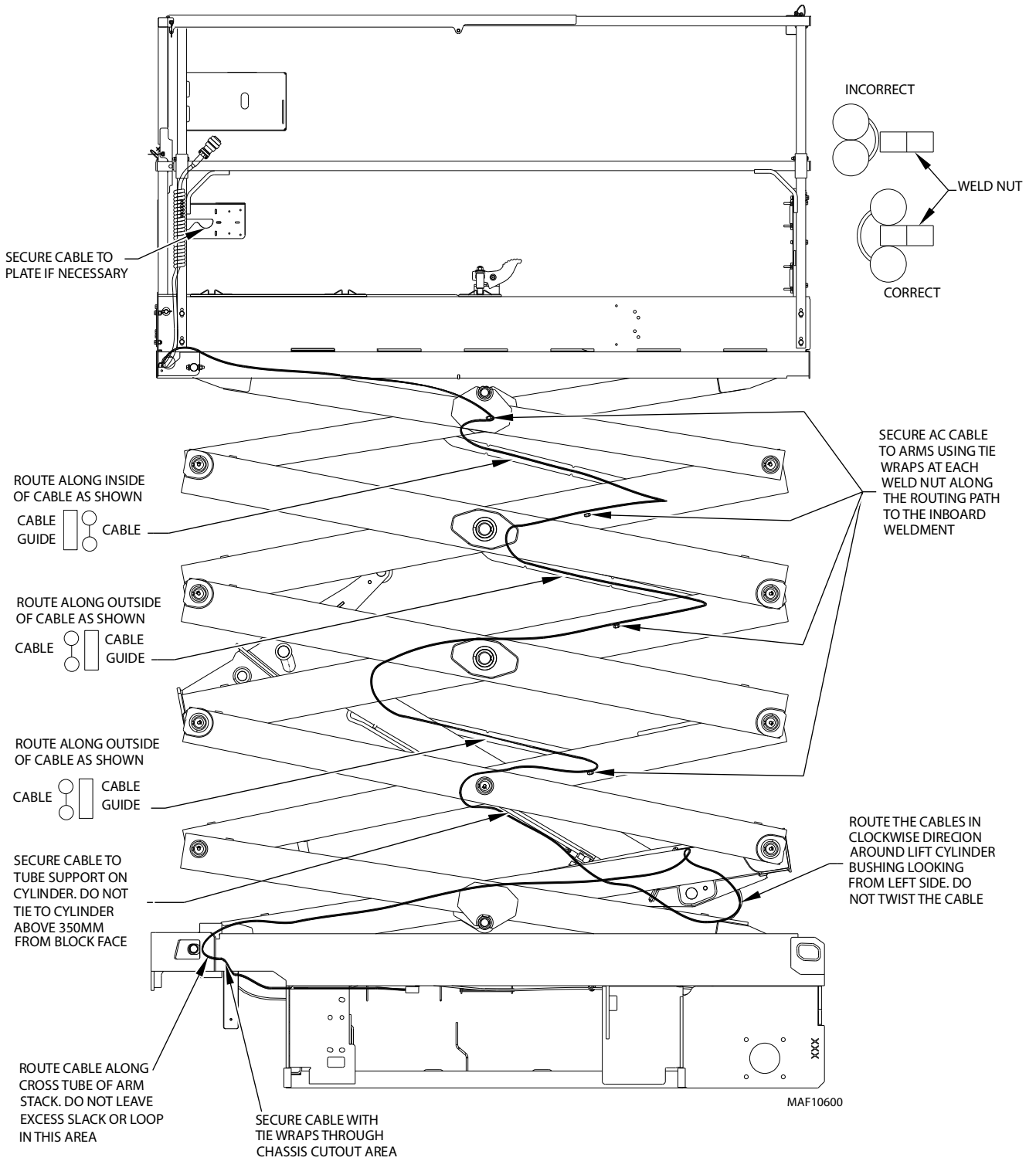

Figure 3-37. Scissor Arm Assembly (R3246) - Cable Routing (Coiled) (With Foot Switch)

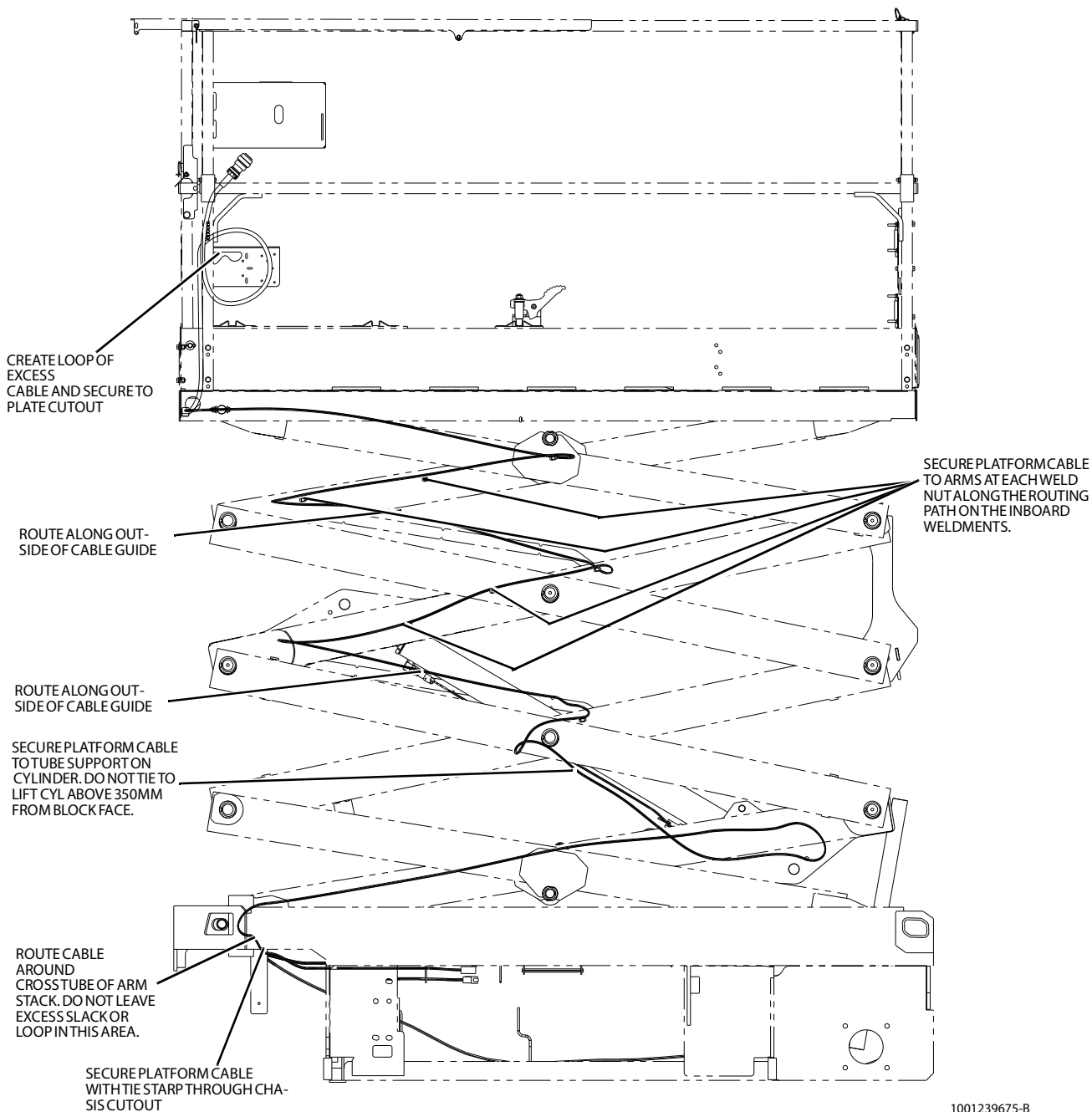

Figure 3-38. Scissor Arm Assembly (R2632) - Cable Routing

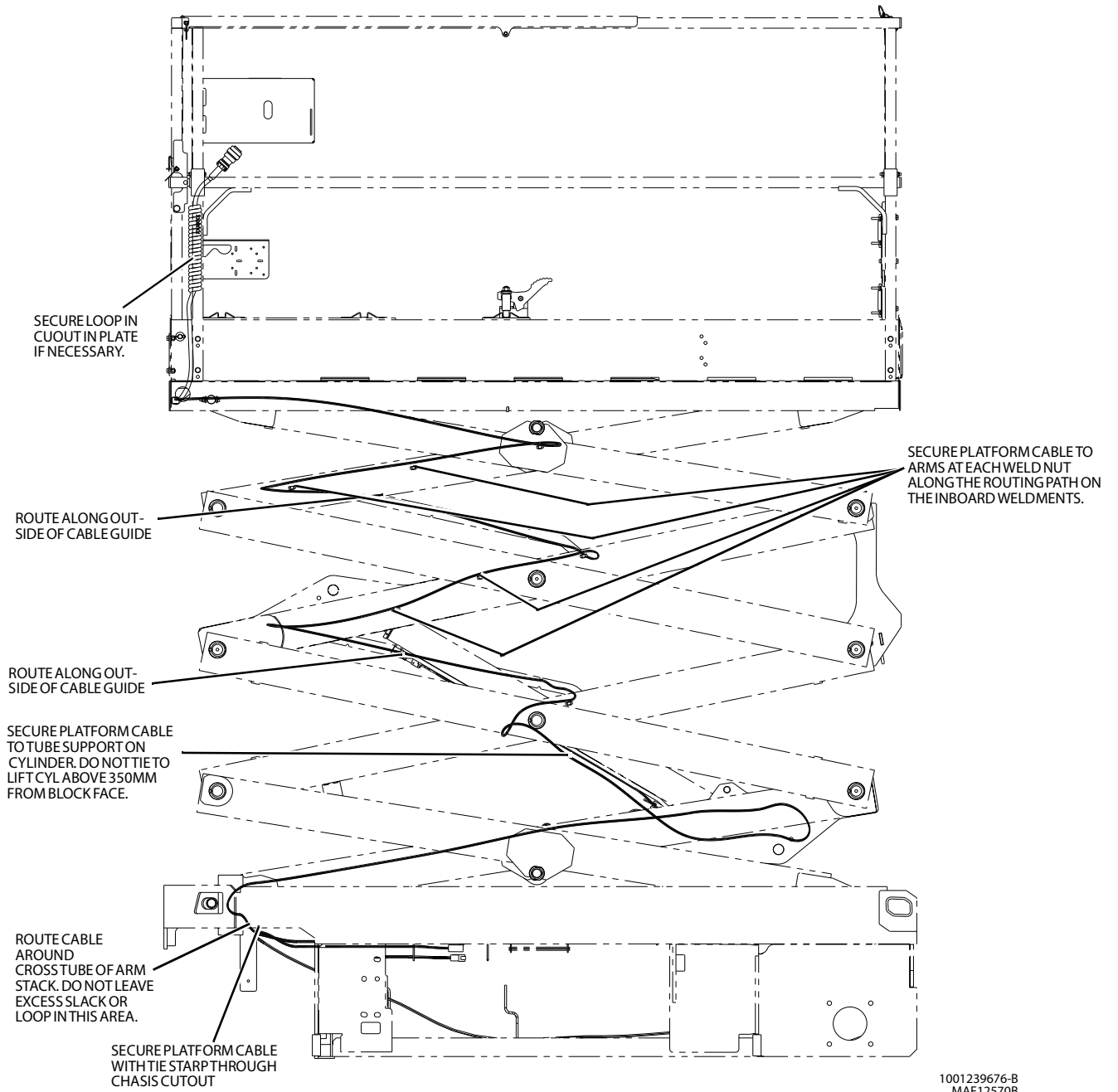

Figure 3-39. Scissor Arm Assembly (R2632) - Cable Routing (Coiled)

SECTION 3 - CHASSIS & SCISSOR ARMS

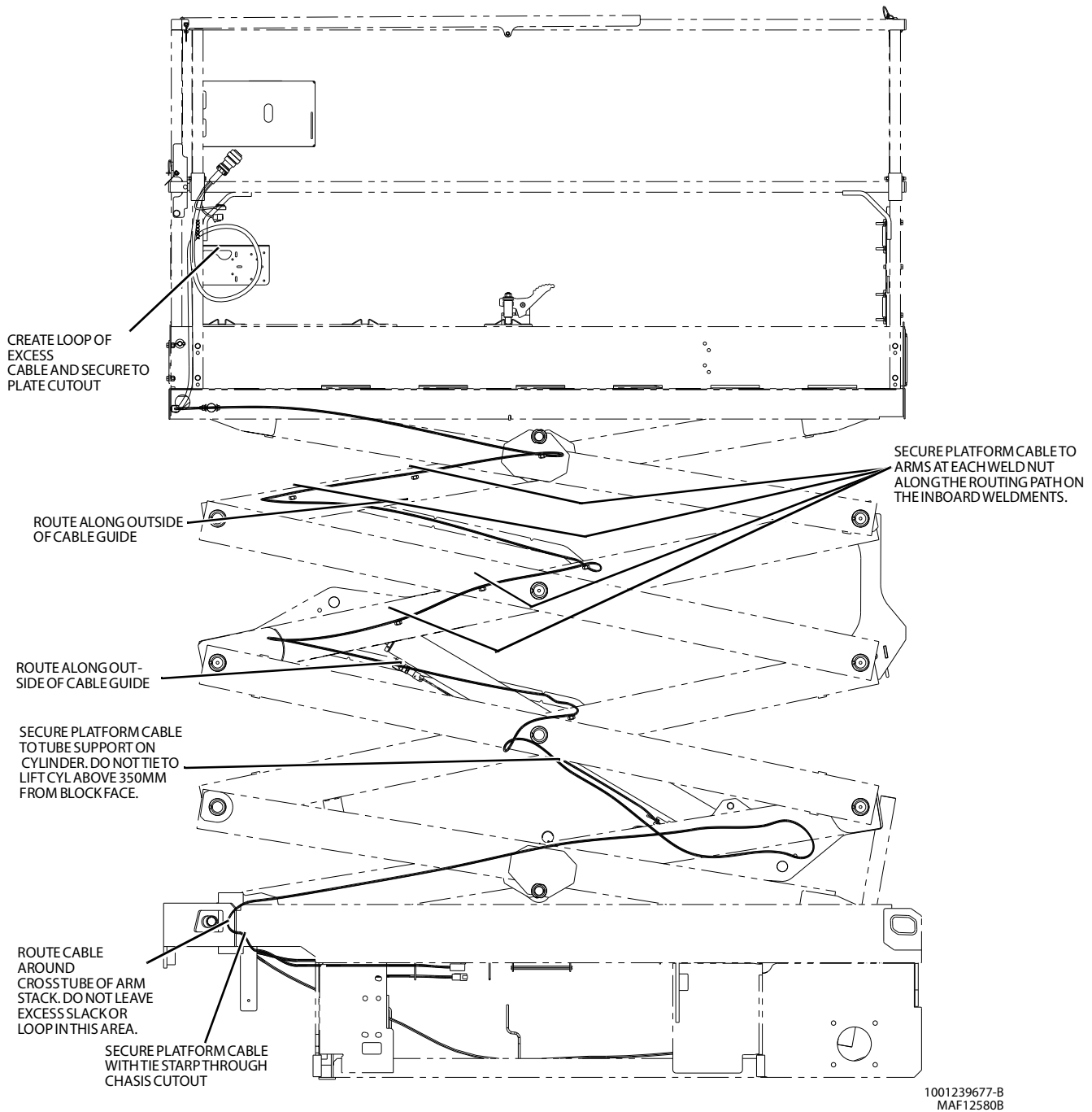

Figure 3-40. Scissor Arm Assembly (R2632) - Cable Routing (With Foot Switch)

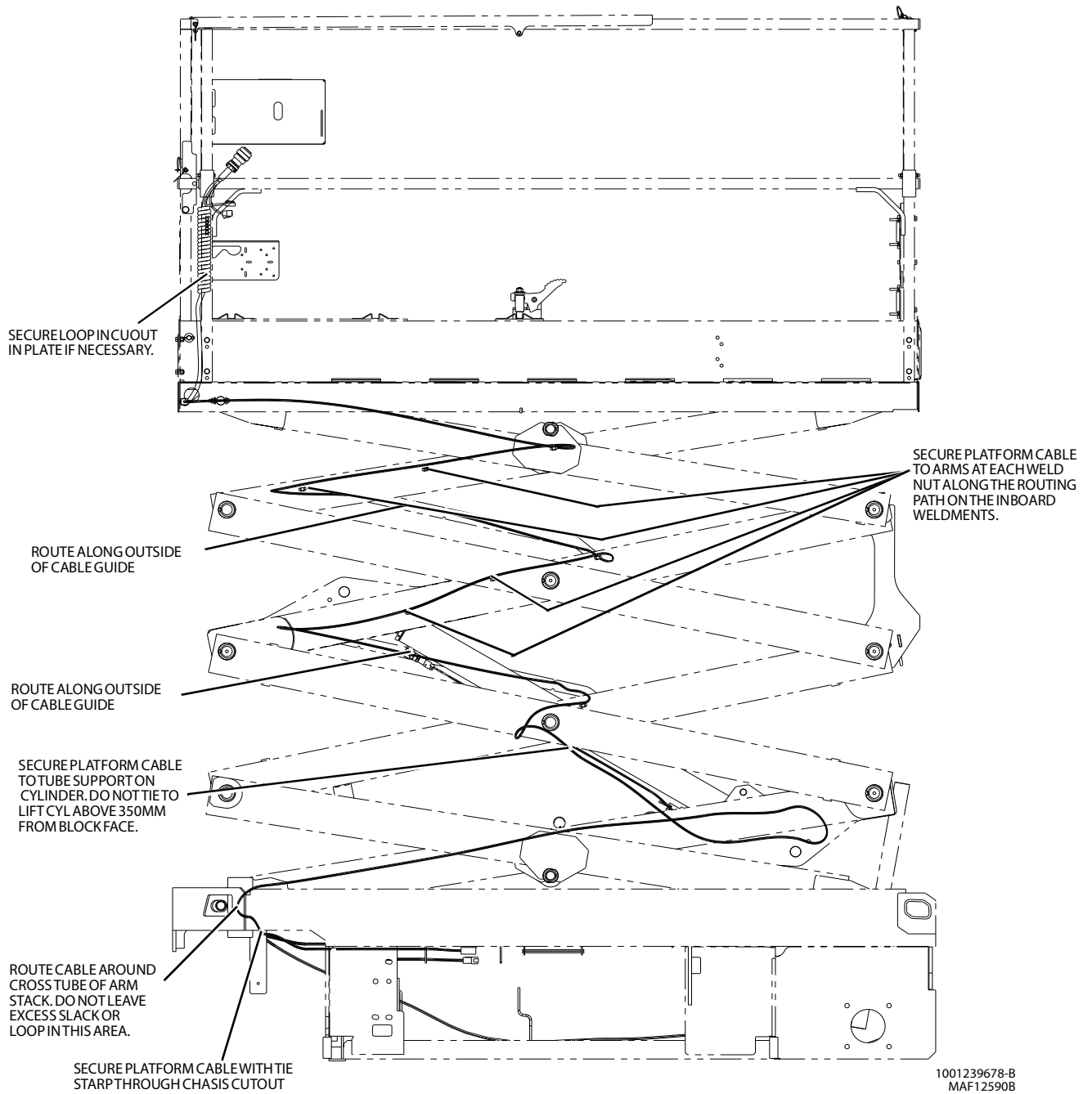

Figure 3-41. Scissor Arm Assembly (R2632) - Cable Routing (Coiled) (With Foot Switch)

SECTION 4. BASIC HYDRAULICS INFORMATION & SCHEMATICS

4.1 CYLINDERS - THEORY OF OPERATION

Cylinders are of the double acting type. The Lift and Steer systems incorporate double acting cylinders. A double acting cylinder is one that requires oil flow to operate the cylinder rod in both directions. Directing oil (by actuating the corresponding control valve to the piston side of the cylinder) forces the piston to travel toward the rod end of the barrel, extending the cylinder rod (piston attached to rod). When the oil flow is stopped, movement of the rod will stop. By directing oil to the rod side of the cylinder, the piston will be forced in the opposite direction and the cylinder rod will retract.

NOTE: *The lift cylinder is a single acting cylinder which takes hydraulic pressure to extend and gravity to retract.*

A holding valve is used in the hydraulic lift circuit to prevent motion unintended by the operator in the event of a hydraulic line failure.

4.2 VALVES - THEORY OF OPERATION

Solenoid Control Valves (Bang-Bang)

Control valves used are four-way, three-position solenoid valves of the sliding spool design. When a circuit is activated and the control valve solenoid energizes, the spool is shifted and the corresponding work port opens to permit oil flow to the component in the selected circuit, with the opposite work port opening to reservoir. Once the circuit is deactivated (control returned to neutral), the valve spool returns to neutral (center) and oil flow is then directed through the valve body and returns to reservoir. A typical control valve consists of the valve body, sliding spool, and two solenoid assemblies. The spool is machine fitted in the bore of the valve body. Lands on the spool divide the bore into various chambers, which, when the spool is shifted, align with corresponding ports in the valve body open to common flow. At the same time other ports would be blocked to flow. The spool is spring-loaded to center position, therefore when the control is released, the spool automatically returns to neutral, prohibiting any flow through the circuit.

Relief Valves

Main relief valves are installed at various points within the hydraulic system to protect associated systems and components against excessive pressure. Excessive pressure can be developed when a cylinder reaches its limit of travel and the flow of pressurized fluid continues from the system control. The relief valve provides an alternate path for the continuing flow from the pump, thus preventing rupture of the cylinder, hydraulic line or fitting. Complete failure of the system pump is also avoided by relieving circuit pressure. The relief valve is installed in the circuit between the pump outlet (pressure line) and the cylinder of the circuit, generally as an integral part of the system valve bank. Relief pressures are set slightly higher than the load requirement, with the valve diverting excess pump delivery back to the reservoir when operating pressure of the component is reached.

Crossover Relief Valves

Crossover relief valves are used in circuits where the actuator requires an operating pressure lower than that supplied to the system. When the circuit is activated and the required pressure at the actuator is developed, the crossover relief diverts excess pump flow to the reservoir. Individual, integral reliefs are provided for each side of the circuit.

Proportional Valve

Flow is proportional to the amount of voltage supplied to the valve coil. Voltage is gained by the machine controller and determined by the position of the joystick.

Manual Descent Valve

The manual descent valve is located on the top of the holding valve on the lift cylinder. The holding valve is a normally closed solenoid valve, and holds the platform in place when raised. When activated, the valve opens to permit lift down. The holding valve is connected to the manual descent valve, which is connected to a cable which, when pulled, manually opens the lift down port of the valve and allows the platform to be lowered in the event hydraulic and/or electric power is lost.

4.3 PUMP/MOTOR

Theory of Operation

The Power Module is essentially a “low-side” switch for the pump motor. The positive terminal of the pump is tied to Battery Positive after the Line Contractor. The negative terminal of the pump connects to the P Terminal of the Power Module, which switches current through MOSFET transistors to the Battery Negative.

For variable speed pump operation, the MOSFET transistors switch On and Off at high frequencies (16kHz). The Duty Cycle is varied to control the voltage applied to the pump motor. When the MOSFET's spend 50% of the period On and 50% Off, approximately ½ of the available Battery Voltage will be applied to the pump motor. Similarly, the MOSFET are On continuously (100% Duty Cycle) to apply all available Battery Voltage to the pump motor (as in Lift Up at full speed).

When the Control System is energized, the voltage at the P Terminal will be approximately +24V (referenced to -B) when the pump is static. The P Terminal will be approximately at +1V (referenced to -B) when the pump is running at full speed (Lift Up from Ground Mode).

Pump Motor Electrical Evaluation

Several basic electrical tests can be performed on the Pump Motor. Failure of one of these evaluations is significant and may indicate that the device is physically damaged.

Refer to Section 8. Make all measurements with a voltmeter set to resistance scale (Ohms). Disconnect main power at the batteries and all pump motor cables during this analysis.

- **Resistance < 5 Ohms between Motor Terminals.** The internal windings are very low impedance and should appear to be a short-circuit for an ordinary voltmeter (other tests can determine if the windings are truly shorted). High resistance can signal worn brushes, a faulty commutator, or open windings.
- **Resistance > 1 Mega-Ohms between Motor Terminals and Motor Housing.** The internal windings should be electrically isolated from the motor housing. Low resistance may be an indication of a broken motor terminal, damaged brush, faulty commutator, or burned winding.

Troubleshooting

The following difficulties can be examined using the JLG Analyzer, a voltmeter, and simple hand tools. Unless otherwise noted, the Control System shall be energized in Ground Mode during testing. For a convenient Ground Reference, place the black meter lead on the negative post of the left battery in the left-side batter compartment. The vehicle should be placed on a smooth, firm, and level surface for all analysis.

1. Open-Circuit between +B Terminal and Pump Motor Positive Terminal

This issue will allow the vehicle to drive, but Lift Up and Steer Functionality will be lost and the Pump Motor will not operate. Under DIAGNOSTICS - PUMP, the JLG Analyzer will show PUMP PWM 100% and PUMP CUR 0.0A when Lift Up is operated from Ground Mode.

As shown in the diagram, the voltage measured between the Pump Motor Positive Terminal and Ground Reference should be 24V. If it is not, examine the cable between the terminal and the Power Module compartment. Examine crimps for corrosion and ensure that bolted connections are tight. Ensure that the cable is not crushed where it passes between the frame side sheets and the cylinder assembly.

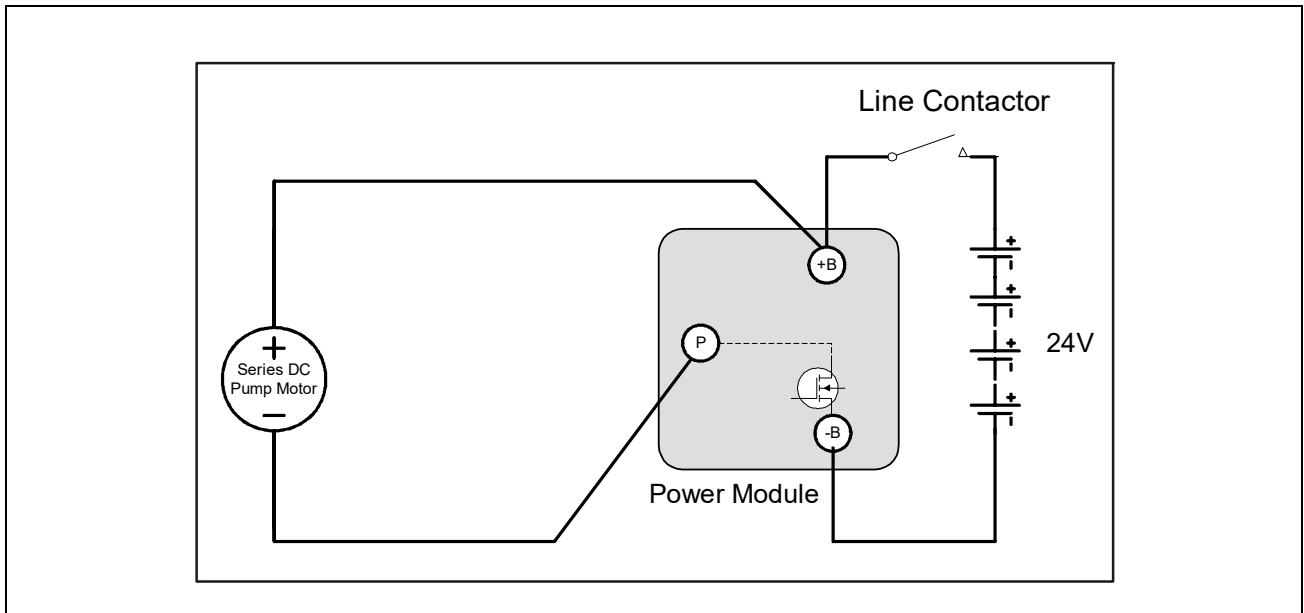

2. Open-Circuit between Pump Motor Negative Terminal and P Terminal

This issue will allow the vehicle to drive, but Lift Up and Steer Functionality will be lost and the Pump Motor will not operate. Under DIAGNOSTICS - PUMP, the JLG Analyzer will show PUMP PWM 100% and PUMP CUR 0.0A when Lift Up is operated from Ground Mode.

After ensuring there is not an Open-Circuit between the +B Terminal and Pump Motor Positive Terminal, check that the voltage measured between the Pump Motor Negative Terminal and Ground Reference is 24V. If not, examine the issues within Open-Circuit Pump Motor. This voltage should ramp to approximately 0V when Lift Up is operated from Ground Mode. If not, examine the cable between the terminal and the Power Module compartment (P Terminal). Examine crimps for corrosion and ensure that bolted connections are tight. Ensure that the cable is not crushed where it passes between the frame side sheets and the cylinder assembly.

3. Open-Circuit Pump Motor

This issue will allow the vehicle to drive, but Lift Up and Steer Functionality will be lost and the Pump Motor will not operate. Under DIAGNOSTICS - PUMP, the JLG Analyzer will show PUMP PWM 100% and PUMP CUR 0.0A when Lift Up is operated from Ground Mode.

Disconnect main power at the batteries to completely de-energize the Control System. Next, detach the cable from Pump Motor Positive Terminal. Using a voltmeter set for resistance mea-

surement (Ohms), ensure that the resistance between the Pump Motor Positive and Negative Terminals is less than 2 Ohms. If not, examine the pump motor for worn brushes or broken terminals. After examination, re-connect the Pump Motor Positive Terminal and main power at the batteries.

4. Short-Circuit between Pump Motor Positive and Negative Terminals

This issue will allow the vehicle to drive, but Lift Up and Steer Functionality will be lost and the Pump Motor will not operate. Under DIAGNOSTICS - PUMP, the JLG Analyzer will show an erratic reading for PUMP PWM% and PUMP CUR will hover around 150A when Lift Up is operated from Ground Mode.

Disconnect main power at the batteries to completely de-energize the Control System. Next, detach both Pump Motor Terminals and insulate them independently. Re-connect main power at the batteries and re-try Lift Up. If the same symptoms persist (erratic PUMP PWM%, PUMP CUR around 150A), examine the cabling between the Pump Motor and Power Module compartment for a short-circuit (most likely near area where cylinder retracts between frame side sheets or near pot-hole mechanism, if equipped). If the symptoms change, suspect a short-circuited (or mechanically frozen) pump motor.

A clamp-on ammeter (set for 200A DC) can be placed on either Pump Motor Cable for verification. During Lift Up, the ammeter will read approximately 150A.

4.4 HYDRAULIC TANK INSTALLATION

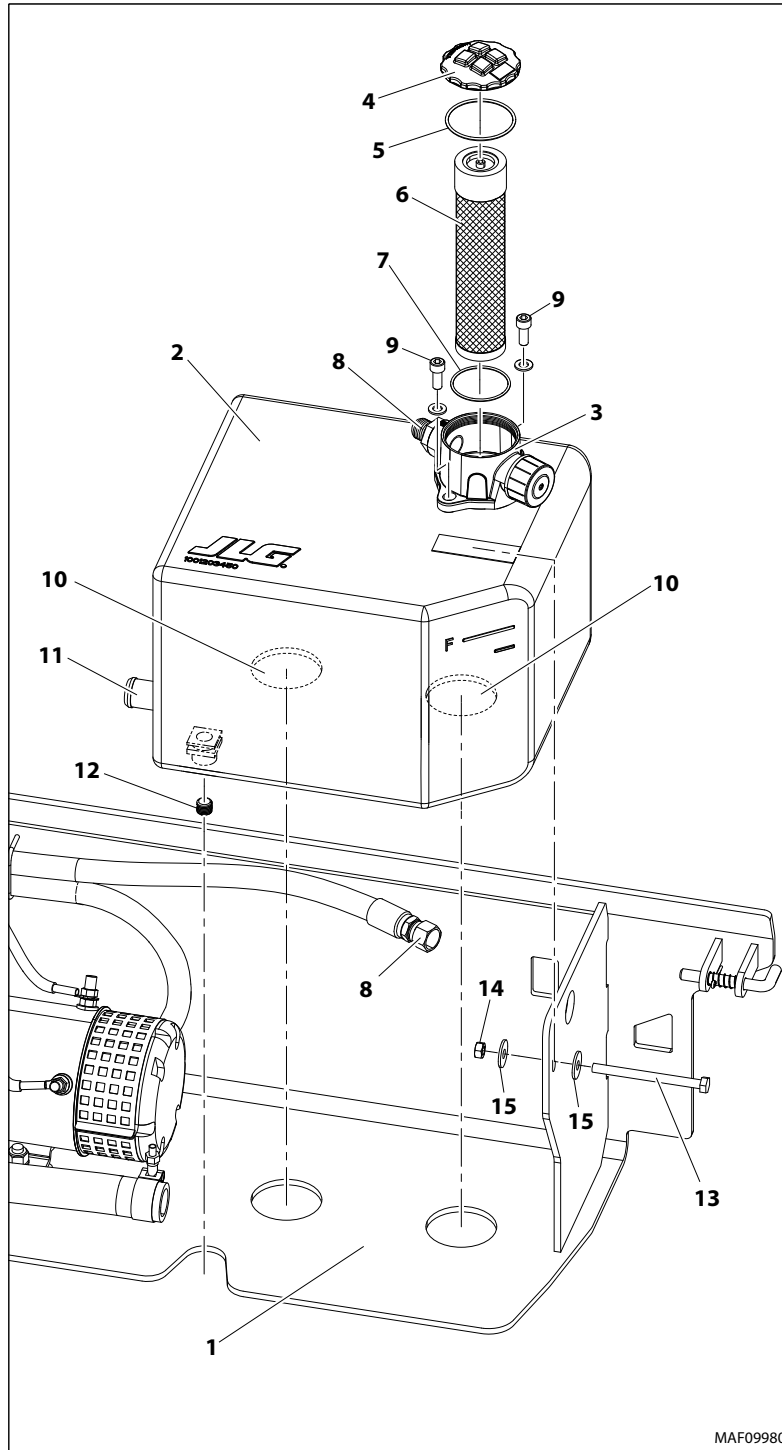

1. Machine Right Side Swing-Out Compartment Door
2. Hydraulic Oil Tank
3. Filter/Return/Breather Housing Assembly
4. Filter/Return Housing Cap
5. Cap O-Ring
6. Hydraulic Oil Filter
7. Bowl O-Ring
8. Tank Return Hose/Port
9. Filter/Return Housing Screws and Washers -
(Torque to 5 ft. lbs. max.)
10. Tank Placement Emboss Features On Bottom of Tank
11. Tank Outlet to Pump
12. Tank Drain Plug
13. Tank Hold-Down Bolt
14. Nut
15. Washers

MAF09980

4.5 HYDRAULIC PUMP AND ELECTRIC MOTOR ASSEMBLY - R3246

The hydraulic pump and motor are located on the right side component swing out door, next to the hydraulic tank assembly.

Pump/Motor Removal

1. Shut off machine power.
2. Disconnect the battery (+) cable or quick disconnect.
3. Open right side component swing out door and locate the hydraulic pump and motor assembly.
4. Label and disconnect the positive (+) and negative (-) power cables on the electric motor.
5. Remove the four bolts (2), and washers from the pump/motor assembly and raise the pump end up above the oil level in the hydraulic tank.
6. Loosen and remove the pump pressure side fitting and hose. Cap the pump port and the hose fitting. Keep pressure hose elevated if necessary.
7. Loosen the suction side hose, keeping it above the oil level in the hydraulic tank. Plug the end of the hose and tie up to keep the end higher than the oil level in the tank.
8. Move the pump/motor assembly to a suitable work surface for disassembly.

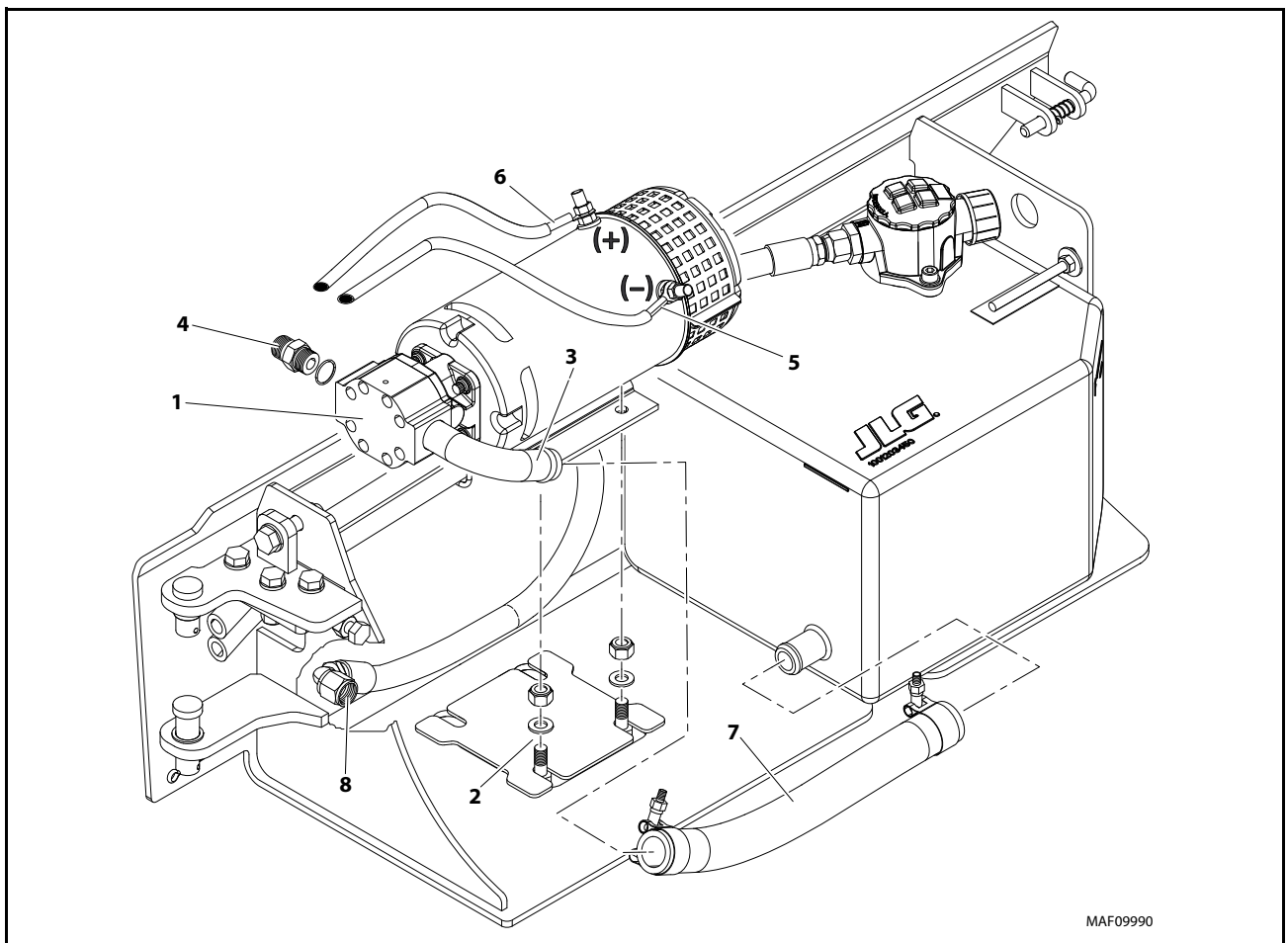

Figure 4-1. Hydraulic Pump - Motor Components

- | | |
|---|-----------------------------------|
| 1. Pump/Motor Assembly | 5. Negative (-) Cable Connection |
| 2. Mounting Plate, Screws, Nuts and Washers | 6. Positive (+) Cable Connection |
| 3. Pump Suction Port | 7. Inlet Hose from Hydraulic Tank |
| 4. Pump Pressure Port Fitting with O-Ring | 8. Outlet Hose to Manifold Valve |

4.6 HYDRAULIC PUMP AND ELECTRIC MOTOR ASSEMBLY - R2632

The hydraulic pump and motor are located on the right side component swing out door, next to the hydraulic tank assembly.

Pump/Motor Removal

1. Shut off machine power.
2. Disconnect the battery cables or quick disconnect.
3. Open right side component swing out door and locate the hydraulic pump and motor assembly.
4. Remove the bolts and washers from the pump/motor assembly and raise the pump end up above the oil level in the hydraulic tank.
5. Loosen and remove the pump pressure side fitting and hose. Cap the pump port and the hose fitting. Keep pressure hose elevated if necessary.
6. Loosen the suction side hose, keeping it above the oil level in the hydraulic tank. Plug the end of the hose and tie up to keep the end higher than the oil level in the tank.
7. Move the pump/motor assembly to a suitable work surface for disassembly.

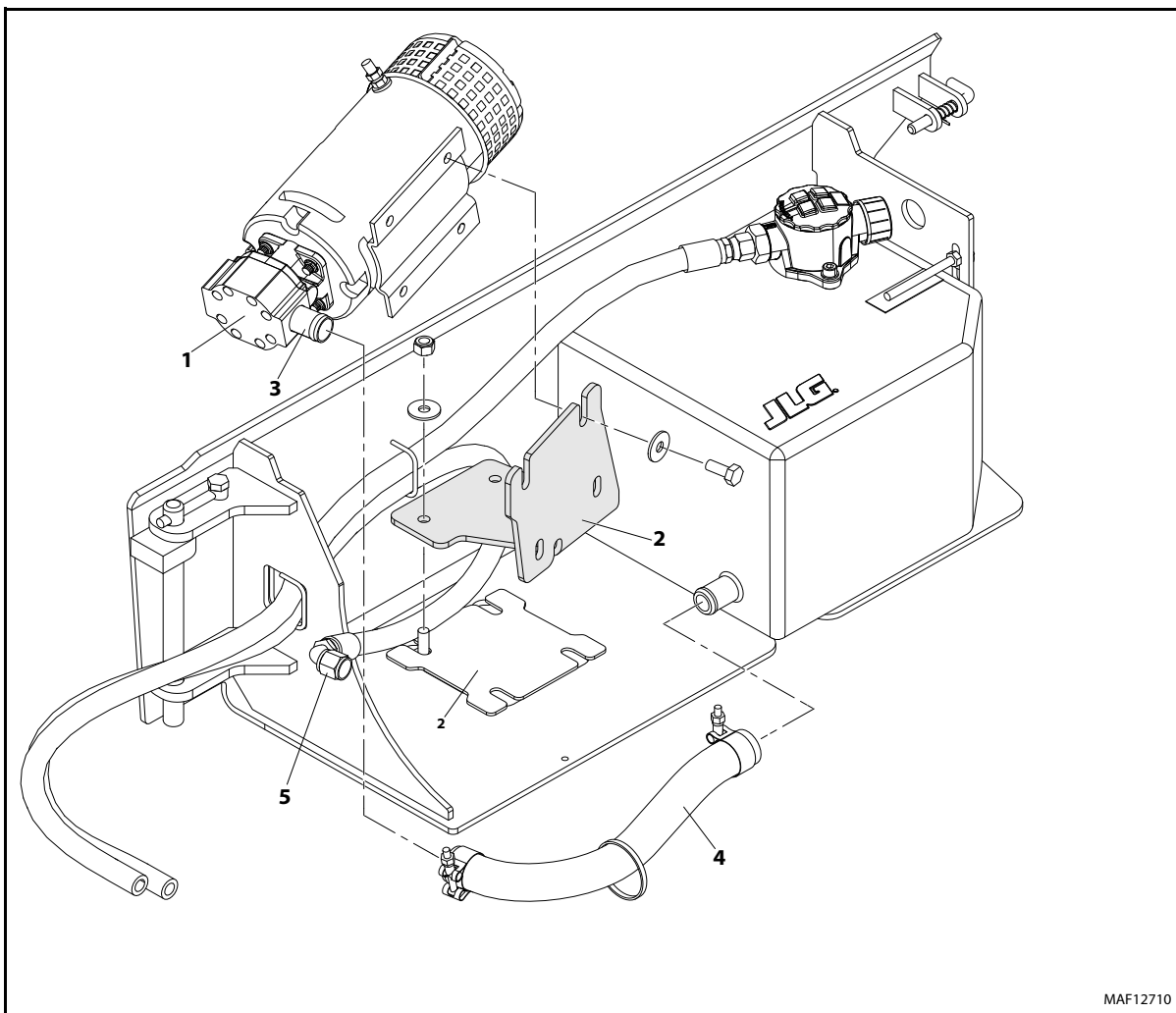

MAF12710

Figure 4-2. Hydraulic Pump - Motor Components

- | | |
|---|------------------------------------|
| 1. Pump/Motor Assembly | 4. Inlet Hose from Hyd.raulic Tank |
| 2. Mounting Plate, Screws, Nuts and Washers | 5. Outlet Hose to Manifold Valve |
| 3. Pump Suction Port | |

Pump/Motor Disassembly

1. Remove the bolts and washers securing the pump to the pump motor.
2. Slide the pump out of the pump motor until the drive shaft clears the motor.
3. If necessary, remove the snap ring from the pump shaft housing and remove the old seal.

2. Replace the pump to motor gasket and slide the pump assembly into the motor assembly aligning the pump shaft with the motor receptacle.
3. Slide the motor all the way into the pump motor and install the bolts and washers.

Pump/Motor Assembly

1. Install a new seal and secure with a new snap ring.

Pump/Motor Installation

Reverse instructions for removal.

When reinstalling the Negative and Positive cable terminal nuts, hold bottom nut and torque the top nut no more than 166 - 177 in. lbs. (19 - 20 Nm).

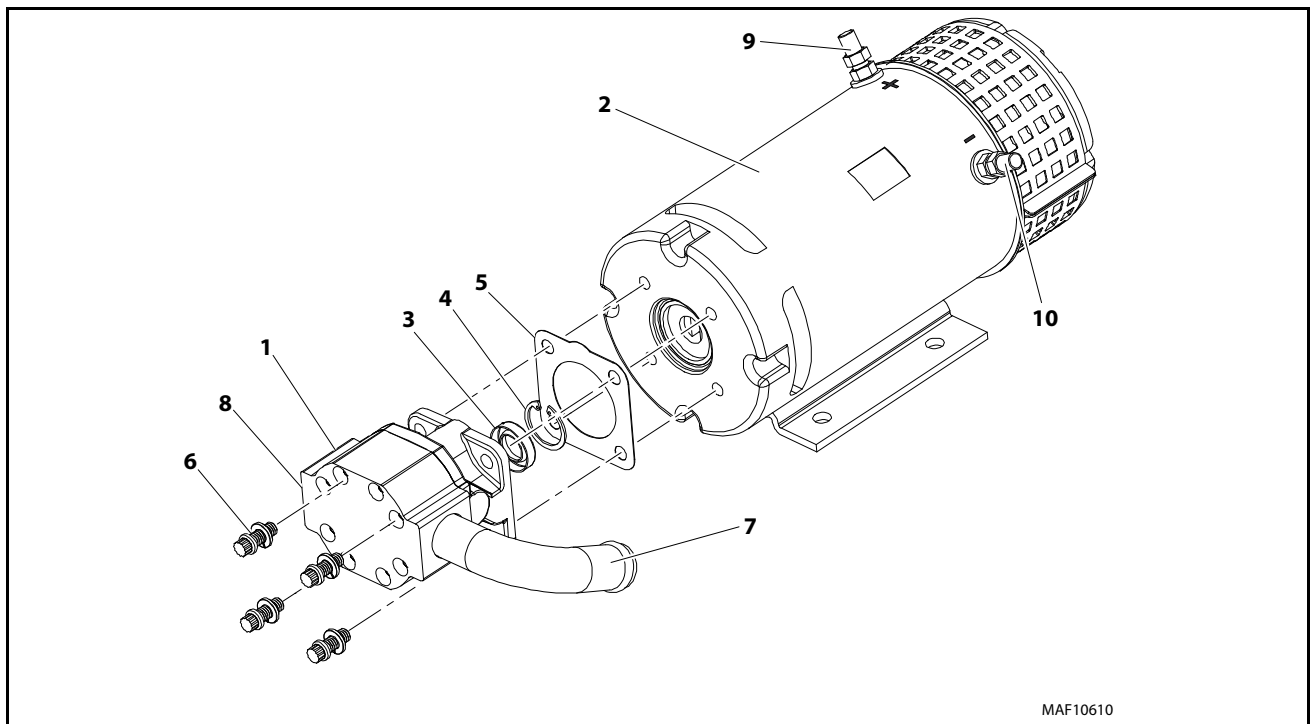
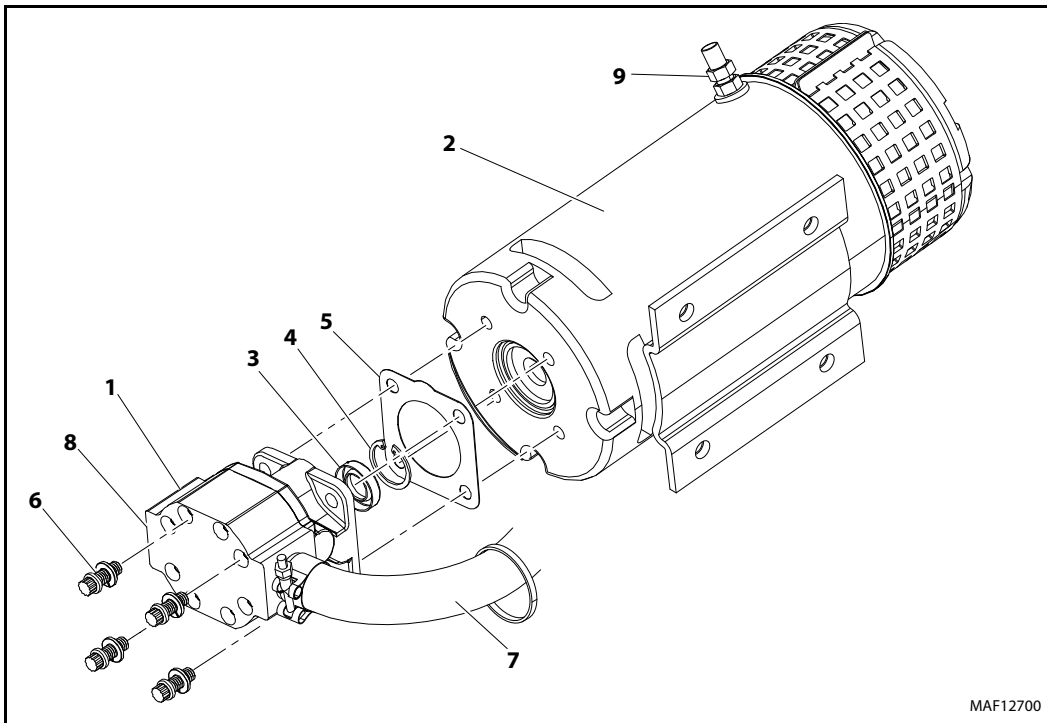

Figure 4-3. Hydraulic Pump (R3246) - Motor Components

- | | |
|--|--|
| <ol style="list-style-type: none"> 1. Hydraulic Pump 2. Electric Motor 3. Pump Drive Shaft Seal 4. Seal to Pump Retaining Snap Ring 5. Pump To Motor Gasket | <ol style="list-style-type: none"> 6. Pump To Motor Bolts and Washers 7. Pump Suction Port 8. Pump Pressure Port 9. Electric Motor Positive (+) Post 10. Electric Motor Negative (-) Post |
|--|--|



MAF12700

Figure 4-4. Hydraulic Pump (R2632) - Motor Components

- | | |
|-------------------------------------|-------------------------------------|
| 1. Hydraulic Pump | 6. Pump To Motor Bolts and Washers |
| 2. Electric Motor | 7. Pump Suction Port |
| 3. Pump Drive Shaft Seal | 8. Pump Pressure Port |
| 4. Seal to Pump Retaining Snap Ring | 9. Electric Motor Positive (+) Post |
| 5. Pump To Motor Gasket | |

4.7 HYDRAULIC MANIFOLD VALVE INSTALLATION

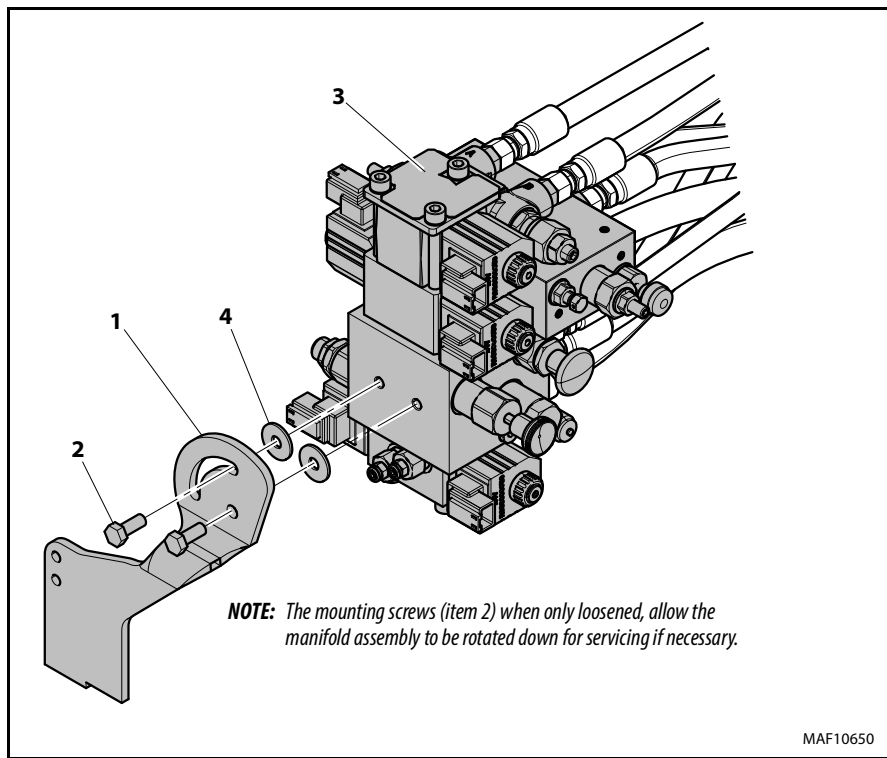

Figure 4-5. Hydraulic Manifold Assembly - Installation
(Located mid-chassis inside right side compartment door)

- | | |
|---|----------------------------|
| 1. Chassis Mounting Plate | 3. Manifold Valve Assembly |
| 2. Valve Mounting Screws - (Apply Medium Strength Threadlocking Compound and Torque to 10 ft. lb. (13.5 Nm) max.) | 4. Valve Mounting Washers |

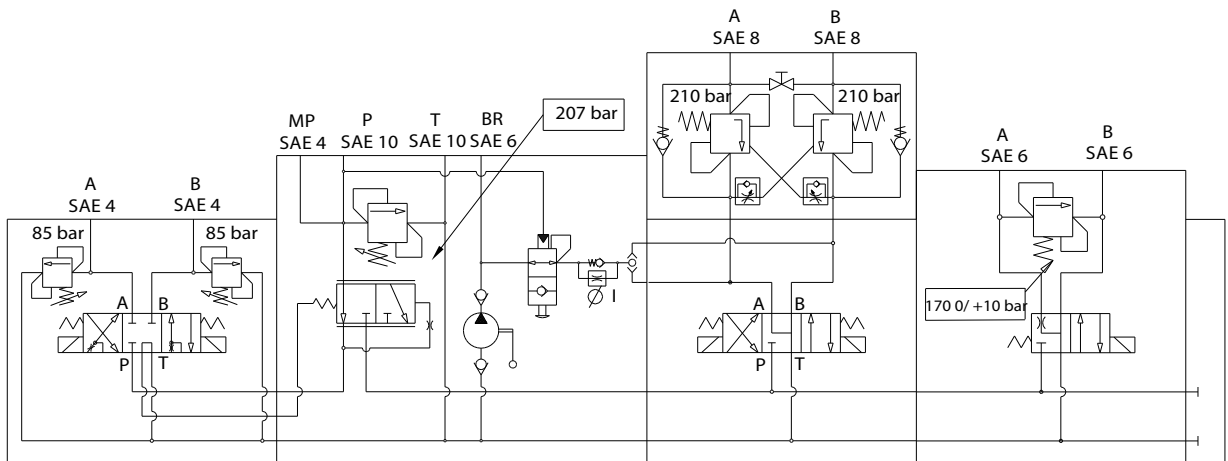

Figure 4-6. Hydraulic Manifold Assembly - Schematic (1001215433)

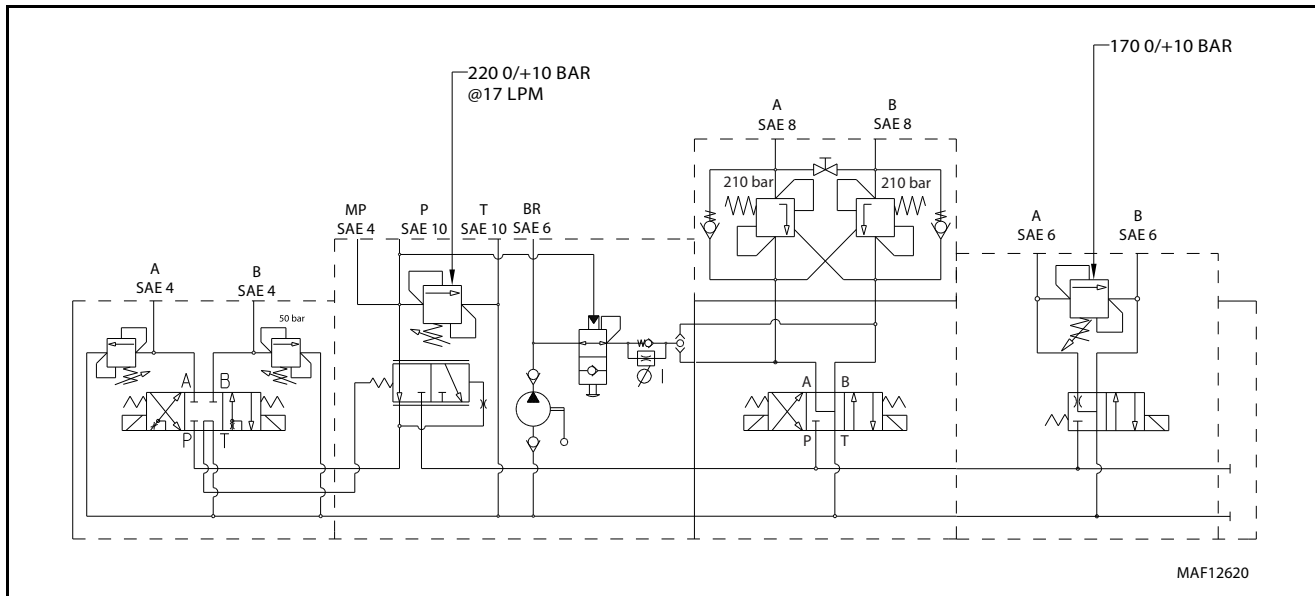

Figure 4-7. Hydraulic Manifold Assembly - Schematic (1001248679)

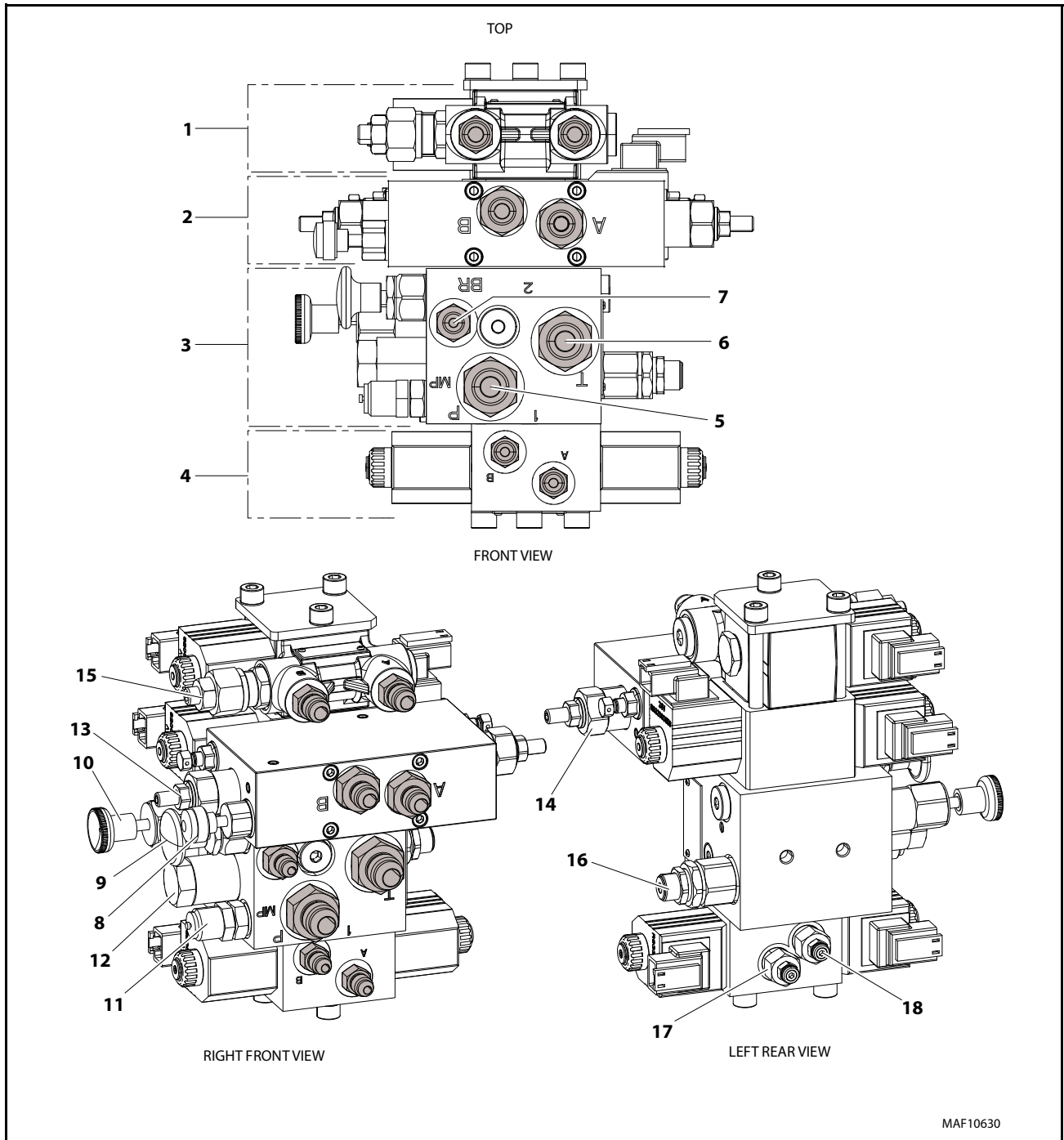

Figure 4-8. Hydraulic Manifold Assembly - Component Location

- | | | |
|--|---------------------------------------|---|
| 1. Lift Cylinder Control Valve Block | 7. Brake Circuit Port | 13. Drive Pressure Relief Adjust (Port B) |
| 2. Drive Motor Control Valve Block | 8. Drive Motor Release (Needle) Valve | 14. Drive Pressure Relief Adjust (Port A) |
| 3. Pressure/Tank Ports and Brake Control Block | 9. Brake Release Valve | 15. Lift Pressure Relief Adjust |
| 4. Steer Cylinder Control Valve Block | 10. Hand Pump | 16. Main Relief Pressure Adjust |
| 5. Pump Pressure Port | 11. Diagnostic Pressure Port | 17. Steer Pressure Relief Adjust (Port A) |
| 6. Tank Return Port | 12. Bypass Valve | 18. Steer Pressure Relief Adjust (Port B) |

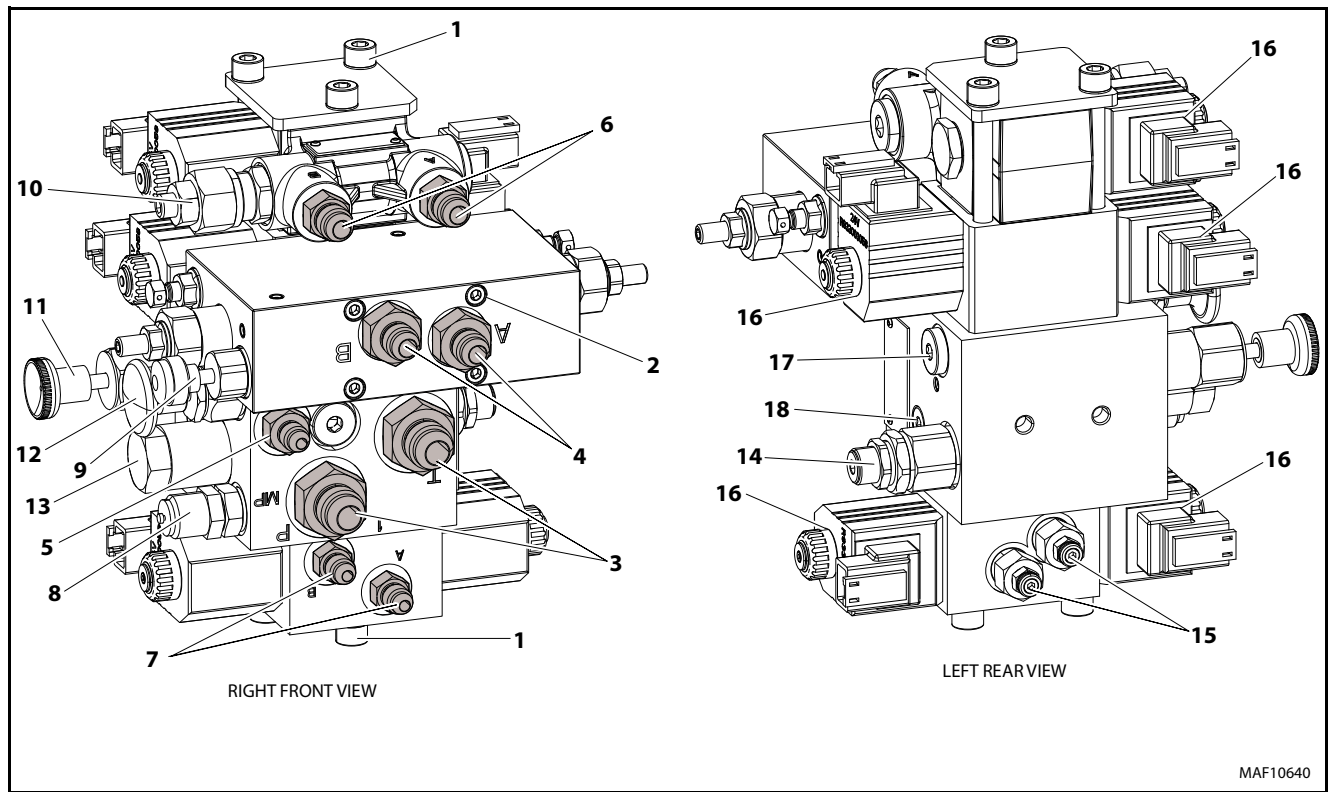
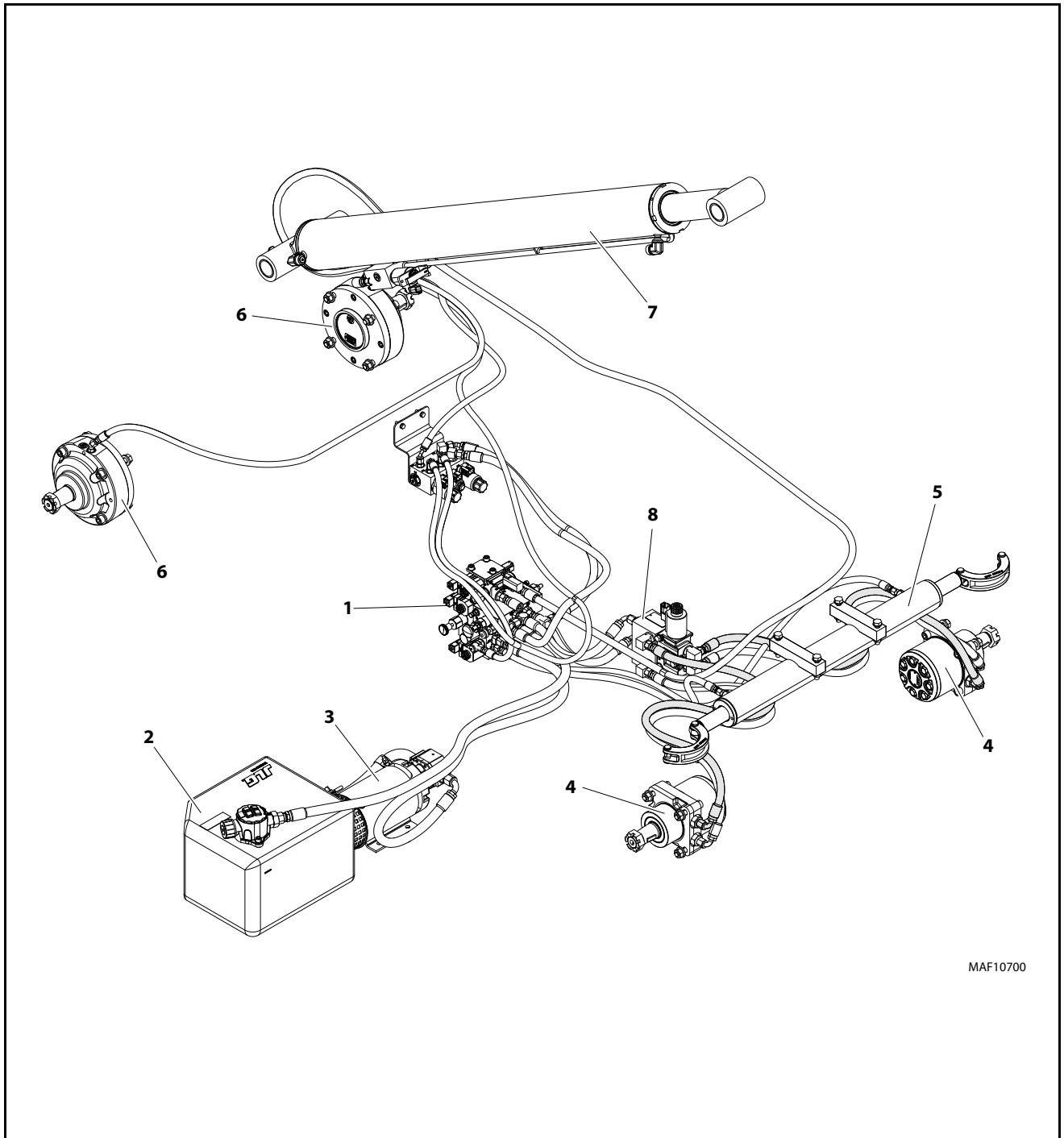

Figure 4-9. Hydraulic Manifold Assembly - Component Torque

- | | | |
|---|--|---|
| 1. Socket Head Screws - 16 ft. lb. (21 Nm) | 7. Port B Fitting - Steer - 23 ft. lb. (31 Nm) | 13. Bypass Valve - 33 ft. lb. (45 Nm) |
| 2. Screw - 4 ft. lb. (5.5 Nm) | 8. MP Port Fitting - 50 ft. lb. (20 Nm) | 14. Main Relief Valve - 31 ft. lb. (43 Nm) |
| 3. Pressure/Tank Port Fittings - 59 ft. lb. (79 Nm) | 9. Needle Valve - 26 ft. lb. (35 Nm) | 15. Steer Relief Valves - 7 ft. lb. (9.5 Nm) |
| 4. Port A/B Fittings - Drive - 36 ft. lb. (49 Nm) | 10. Relief Valve - Lift - 31 ft. lb. (43 Nm) | 16. Solenoid Valves - 4 ft. lb. (5.5 Nm)
(Coil Resistance 22 Ohms) |
| 5. Brake Port Fittings - 20 ft. lb. (27 Nm) | 11. Hand Pump - 28 ft. lb. (38 Nm) | 17. Plug - 9 ft. lb. (12.5 Nm) |
| 6. Port A/B Fitting - Lift - 31 ft. lb. (42 Nm) | 12. Brake Release Valve - 33 ft. lb. (45 Nm) | 18. Plug - 23 ft. lb. (32 Nm) |



MAF10700

Figure 4-10. Hydraulic Hose Routing (R3246)

- | | | |
|-------------------------------|-----------------------------------|---|
| 1. Manifold Valve Block | 4. Drive Motors (Interchangeable) | 7. Lift Cylinder -
(Also reference Figure 3-34. to Figure 3-37.) |
| 2. Oil Tank/Filter/Drain Plug | 5. Steer Cylinder | 8. Traction Valve |
| 3. Pump/Motor | 6. Brakes | |

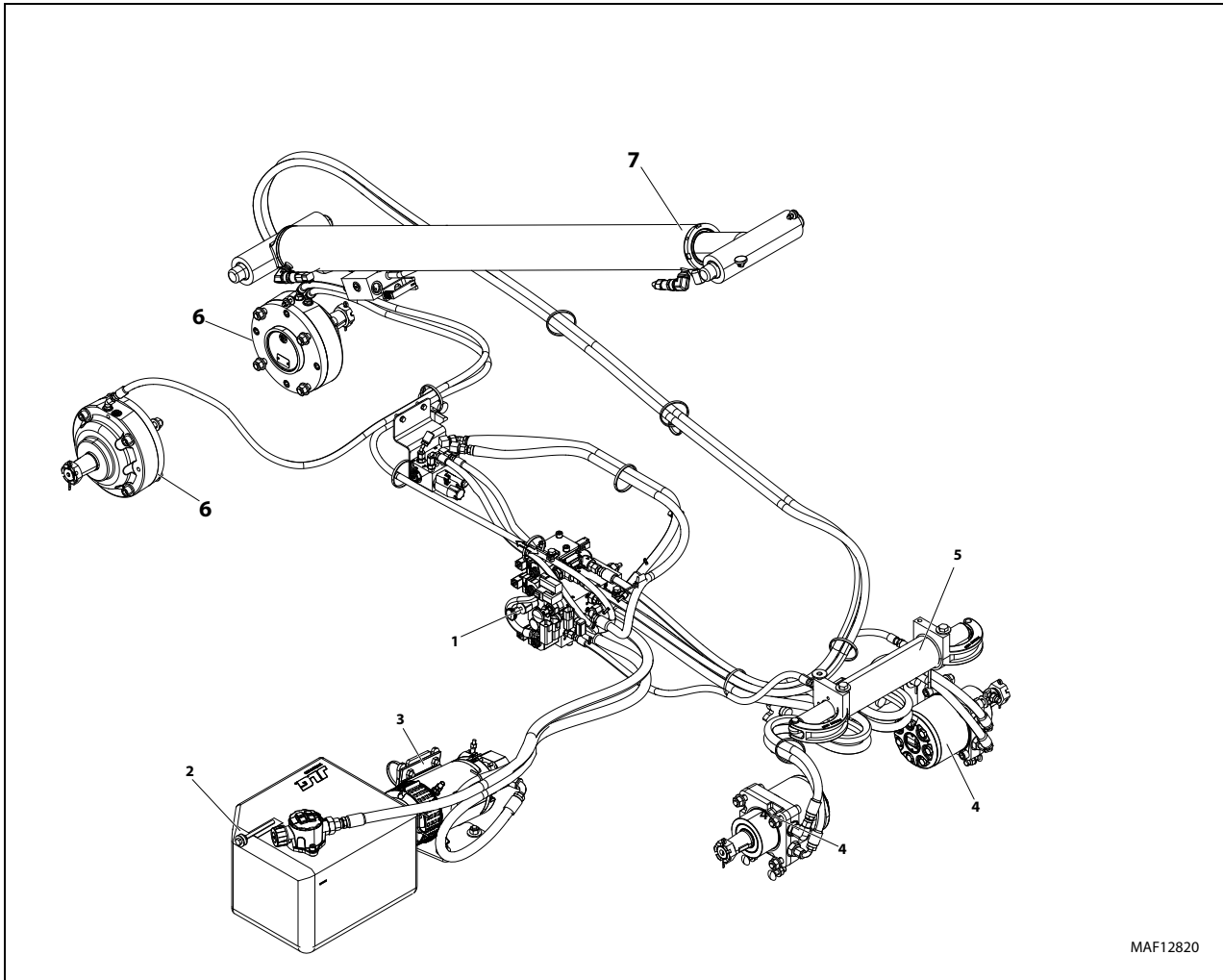

MAF12820

Figure 4-11. Hydraulic Hose Routing (R2632)

- | | | |
|-------------------------------|-----------------------------------|----------------------------------|
| 1. Manifold Valve Block | 4. Drive Motors (Interchangeable) | 7. Lift Cylinder - |
| 2. Oil Tank/Filter/Drain Plug | 5. Steer Cylinder | (Also reference (Figure 3-38. to |
| 3. Pump/Motor | 6. Brakes | Figure 3-41.) |

4.8 DRIVE MOTOR INSTALLATION

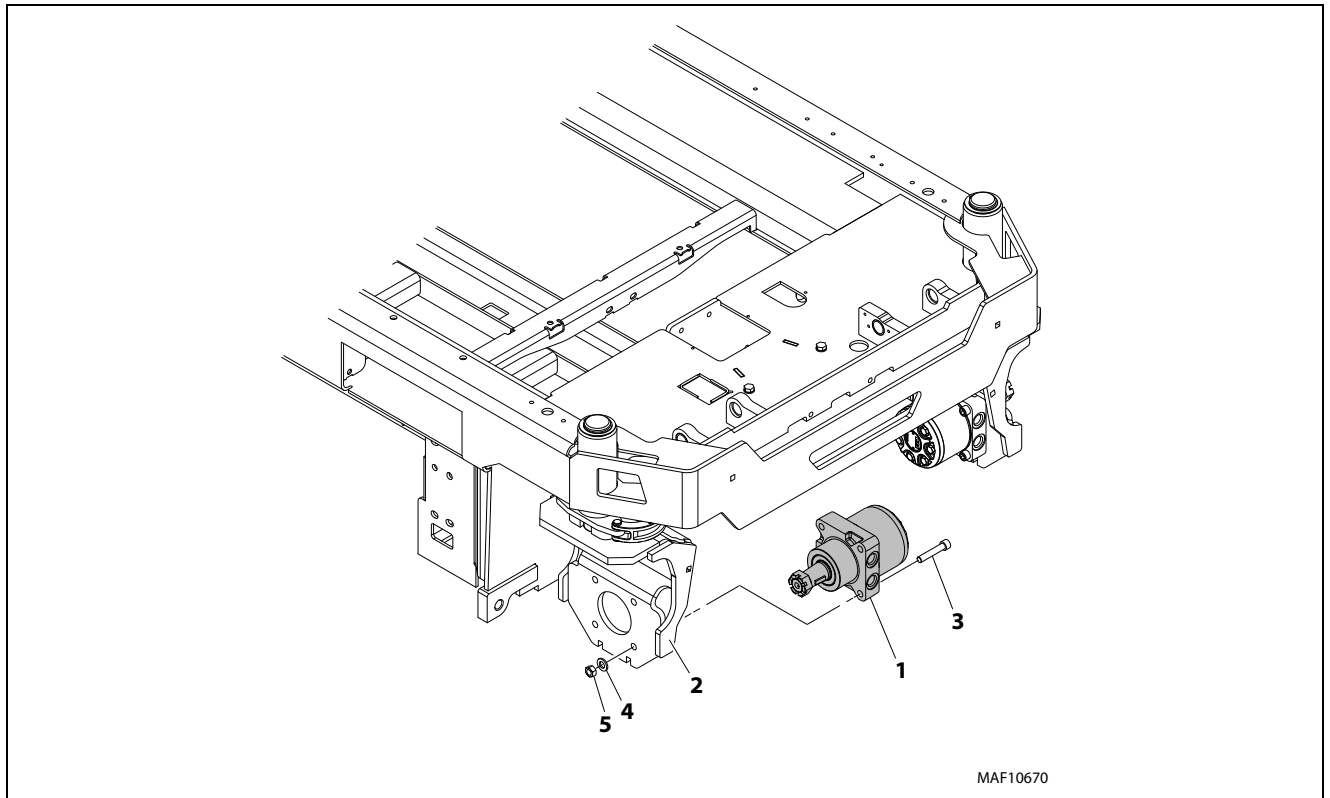

Figure 4-12. Drive Motor - Installation
(Right Motor shown, Left Motor the same, flip motor over, keeping ports facing forward.)

- | | |
|--|------------------------|
| 1. Hydraulic Drive Motor | 4. Washers |
| 2. Steer/Spindle Mount | 5. Motor Mounting Nuts |
| 3. Motor Mounting Screws (Apply Medium Strength Thread-locking Compound on assembly) Torque to 74 ft. lb. (100 Nm) | |

NOTE: The drive motors may make an audible noise when driving and turning the machine. This condition is normal due to the hydraulic oil flow characteristics of the series drive circuit.

4.9 HYDRAULIC BRAKE INSTALLATION

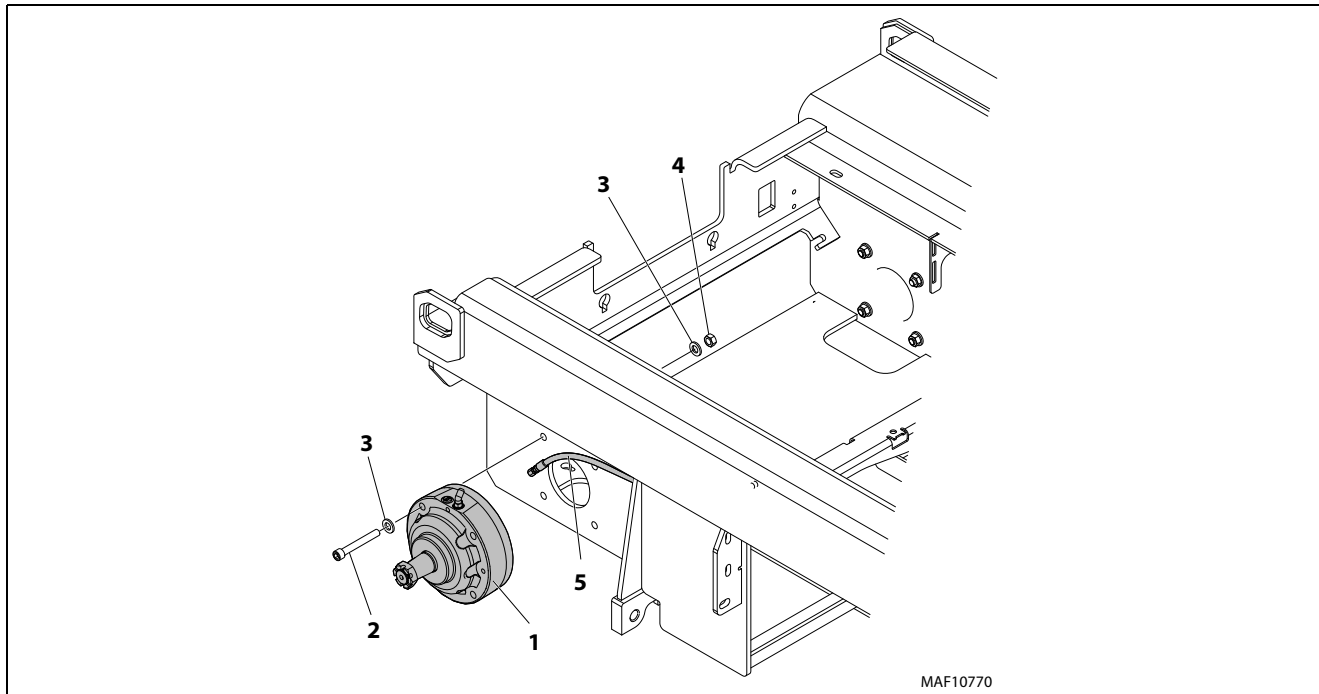

Figure 4-13. Hydraulic Brake - Installation

- | | |
|---|---|
| 1. Hydraulic Brake Assembly (Mount with Ports on Top) | 3. Washers (Inside of Frame) |
| 2. Mounting Screws (Apply Medium Strength Threadlocking Compound on assembly and Torque to 74 ft. lb. (100 Nm)) | 4. Mounting Nuts |
| | 5. Hyd.raulic Hose to Right Side Brake Assembly |

4.10 TOWING

It is not recommended to tow this machine except in the event of an emergency such as a machine malfunction or total machine power failure. However, provisions have been made for extreme cases.

Hydraulic Brake Release for Towing

(See Figure 4-14.)



CHOCK WHEELS OR SECURE MACHINE WITH TOW VEHICLE.

1. At the ground control station turn power off by pressing the Emergency Stop switch.
2. Open the right side compartment door and the find main hydraulic manifold control valve.
3. Perform the following to set the drive motor control valve to tow mode. On the drive control valve locate the tow mode needle valve knob (1), Screw out the valve until it stops.
4. On the main valve body, to release the brakes, push the BLACK brake override button (2) in, (there is a detent which will hold the valve in place).
5. Pump the RED Knob (3) until pressure builds, approximately 5 to 10 strokes. The brakes should now be released.
6. After towing is complete, release the BLACK brake override button (2) and screw the tow mode needle valve knob (1) all the way in to reset the hydraulic brake. Chock the machine wheels.

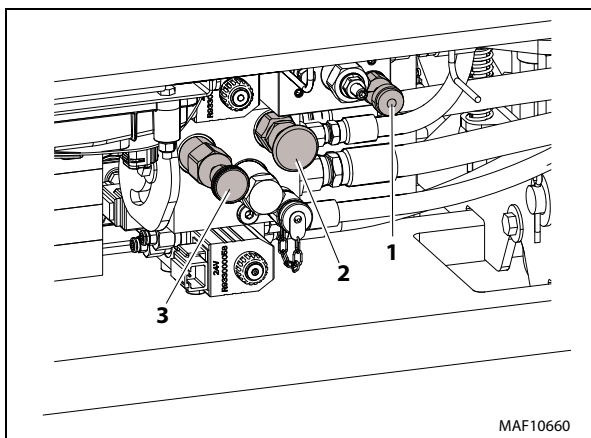
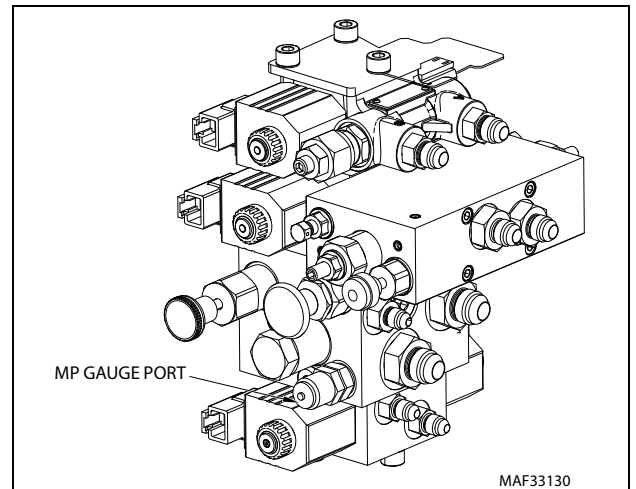

Figure 4-14. Hydraulic Brakes - Manual Disengage
(Inside Right Side Compartment Door)

4.11 PRESSURE SETTING PROCEDURE

Install pressure gauge capable of measuring 4000 psi (276 bar) at "MP" port of main control valve.



Machine Model Pressure setting

Table 4-1. Valve Pressure Per Machine Model

Relief Valve	Pressure Setting per Machine Model in lb/in2 (bar)	
	R3246	R2632
Main	3200 (220)	3000 (207)
Lift-Up	2550 (176)	2550 (176)
Steer Left	1150 (80)	1150 (80)
Steer Right	1150 (80)	1150 (80)

Main Relief

1. Enter Access Level 2 on the analyzer and go to the CALIBRATION and select "Relief Pressure".
2. Adjust main relief until pressure at the MP port gauge matches the value specified in Table 4-1.

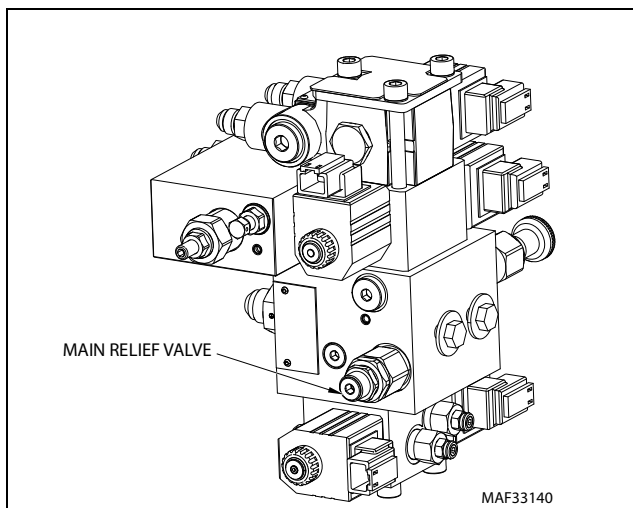

Lift Up Relief

1. With lift-up set at the default personality, raise the scissor platform from the ground control panel until the platform is at full height.
2. Adjust lift-up relief until pressure at the MP port gauge matches the value specified in Table 4-1.

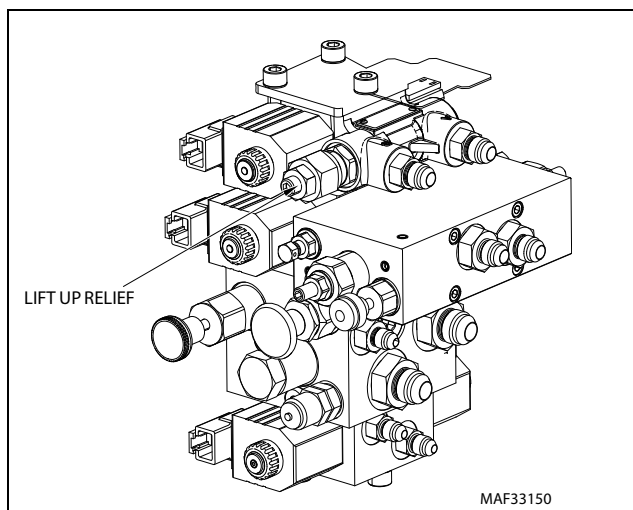

Steer Relief

NOTE: To diagnose cylinder problems it may be necessary to install diagnostic fittings at the steer cylinder ports due to the steer priority valve restricting flow.

1. Reduce steer personality to 26%. If personality is not reduced, main relief will be active.
2. Steer fully to the right then adjust steer right relief until pressure at the MP port gauge matches the value specified in Table 4-1.

3. Steer fully to the left then adjust steer left relief until pressure at the MP port gauge matches the value specified in Table 4-1.
4. Return Steering Personalities to their original settings.

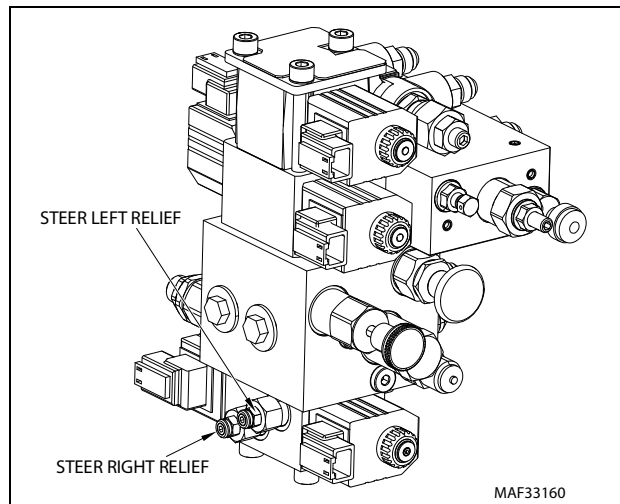

NOTE: Drive module counterbalance valves and bleed screws must not be adjusted (Highlighted in Grey).

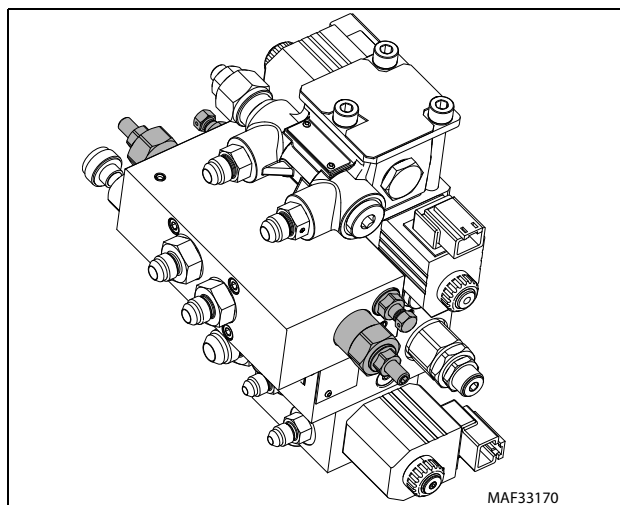

4.12 CYLINDER CHECKING PROCEDURE

NOTE: Cylinder check must be performed anytime a system component is replaced or when improper system operation is suspected.

1. Using all applicable safety precautions, activate pump motor and fully extend cylinder to be checked.
2. Carefully disconnect hydraulic hoses from retract port of cylinder. There will be some initial weeping of hydraulic fluid which can be caught in a suitable container. After the initial discharge, there should be no further drainage from the retract port.
3. Activate pump motor and extend cylinder.
4. If cylinder retract port leakage is less than 6-8 drops per minute, carefully reconnect hose to port and retract cylinder. If leakage continues at a rate of 6-8 drops per minute or more, cylinder repair must be made.

NOTE: Steps 5 through 7 for Steer Cylinder Only.

5. With cylinder fully retracted, shut down machine power and carefully disconnect hydraulic hose from cylinder extend port.
6. Activate pump motor and retract cylinder. Check extend port for leakage.
7. If extend port leakage is less than 6-8 drops per minute, carefully reconnect hose to extend port, than activate cylinder through one complete cycle and check for leaks. If leakage continues at a rate of 6-8 drops per minute or more, cylinder repairs must be made.

4.13 LIFT CYLINDER REMOVAL INSTALLATION

NOTE: If there is a pump failure, a crane or a forklift can be used to raise the platform.

⚠ WARNING

NEVER WORK UNDER AN ELEVATED PLATFORM UNTIL IT HAS BEEN RESTRAINED FROM MOVEMENT WITH SAFETY PROPS, BLOCKING, OR OVERHEAD SLINGS.

Self-locking fasteners, such as nylon insert and thread deforming locknuts, are not intended to be reinstalled after removal. Always use new replacement hardware when installing locking fasteners.

1. Use an overhead crane or fork truck to secure the platform and scissor arms before lift cylinder removal begins.
2. Cut any wire ties that attach any cables or hoses to the lift cylinder.

NOTICE

DISCONNECT MAIN POWER FROM THE BATTERIES BEFORE REMOVING ANY COMPONENTS FROM THE LIFT CYLINDER ASSEMBLY.

3. Remove the valve connector, the two hoses and the manual descent cable from the cylinder.

NOTE: To avoid having to readjust the manual descent, remove the large nut located behind the manual descent bracket as shown. Also see Figure 3-30. for lift cylinder mounting hardware configurations.

4. Ensuring that the platform and scissor arms are properly secure, support the lift cylinder and remove the lift cylinder pin and rest of the cylinder on the arm cross tube directly below the cylinder.
5. Place the cylinder on a clean workbench.
6. For installation reverse above steps.

Lift Cylinder - LSS Pressure Sensor Location

Lift cylinders on machines with the Load Sensing System (LSS) are equipped with pressure sensing transducers. These sensors are installed on the lift cylinder manifold block next to the descent valve.

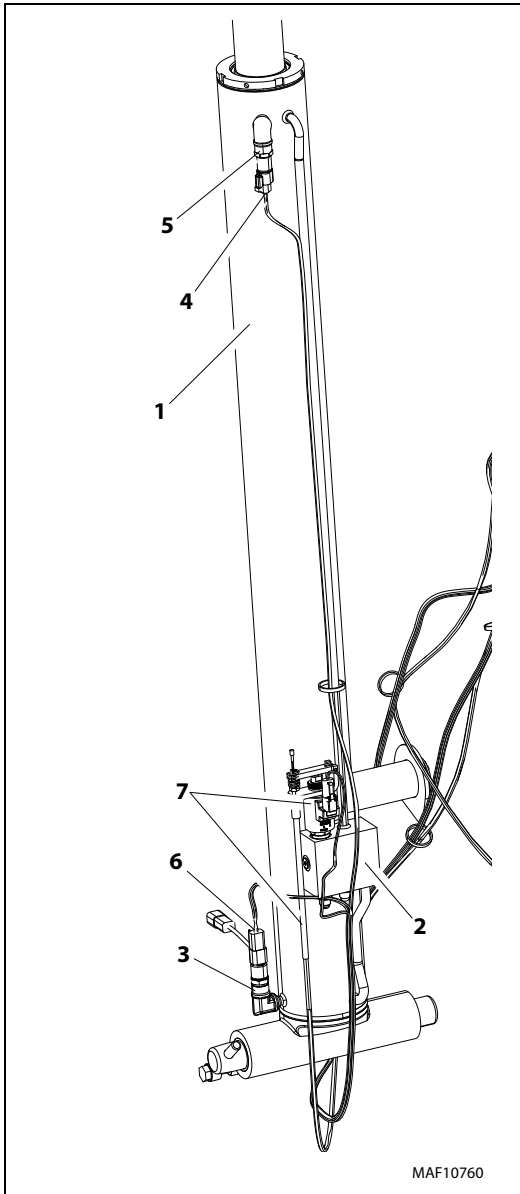
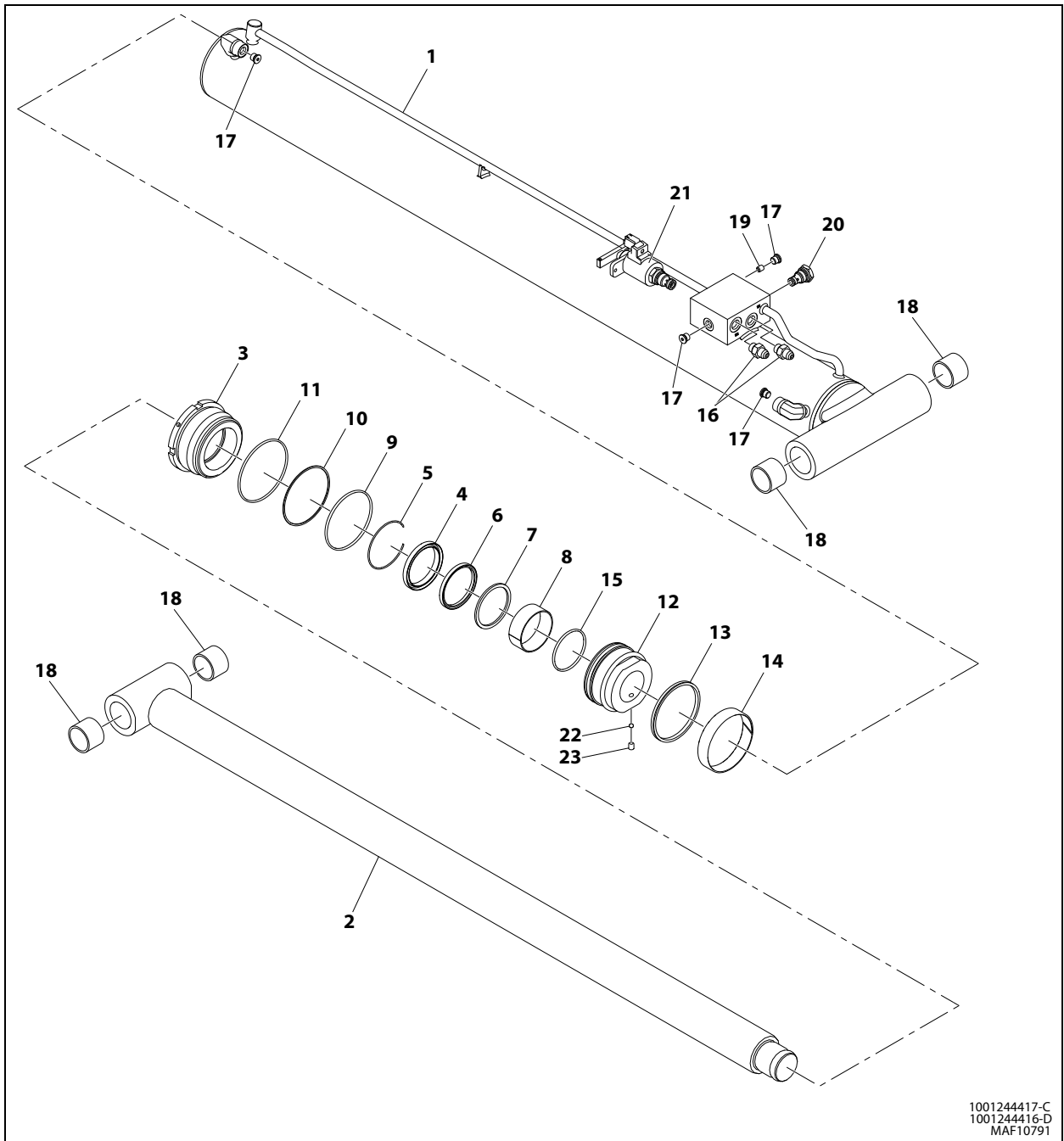

Figure 4-15. LSS Pressure Sensor Location

- | | |
|---|---|
| 1. Lift Cylinder | 5. Pressure Sensor 2-
(Torque to 14 ft lb (19 Nm)) |
| 2. Cylinder Valve Block | 6. Sensor 2 - Harness Connector |
| 3. Pressure Sensor 1-
(Torque to 11.1 ft lb (15 Nm)) | 7. Manual Descent Valve and
Release Cable |
| 4. Sensor 1 - Harness Connector | |



1001244417-C
1001244416-D
MAF10791

Figure 4-16. Lift Cylinder

- | | | | |
|-------------------|------------------|------------------|------------------------------|
| 1. Barrel | 7. Ring, Backup | 13. Seal, Piston | 19. Orifice |
| 2. Rod | 8. Bearing | 14. Ring, Wear | 20. Cartridge Valve |
| 3. Head | 9. O-Ring | 15. O-Ring | 21. Cartridge Solenoid Valve |
| 4. Wiper | 10. Ring, Backup | 16. Fitting | 22. Ball |
| 5. Retaining Ring | 11. O-Ring | 17. Plug | 23. Setscrew |
| 6. Seal, Rod | 12. Piston | 18. Bearing | |

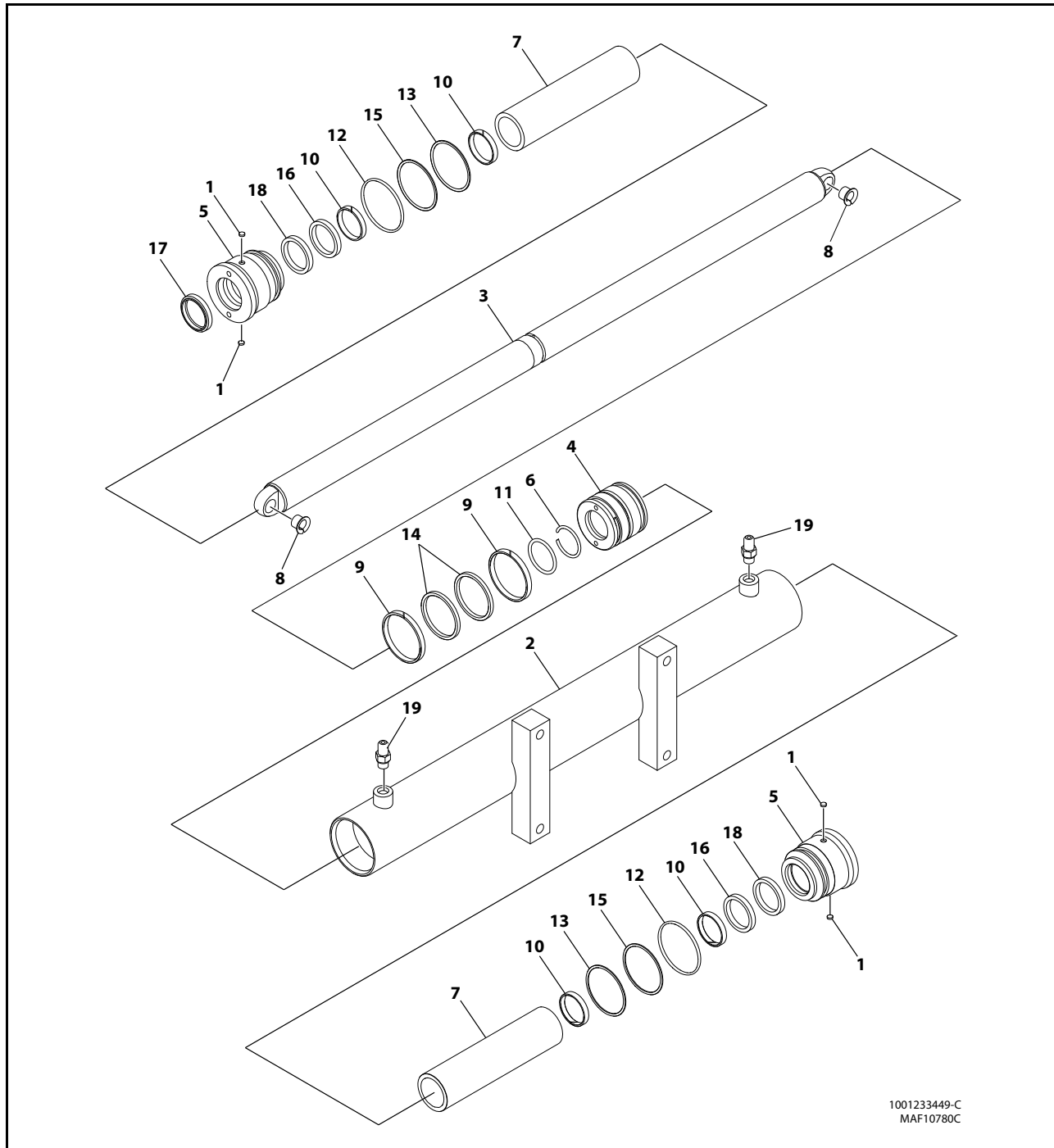

1001233449-C
MAF10780C

Figure 4-17. Steer Cylinder (R3246)

- | | | | |
|-----------|----------------|------------------|-----------------------|
| 1. Lock | 6. Ring | 11. O-Ring | 16. Seal |
| 2. Barrel | 7. Spacer | 12. O-Ring | 17. Seal, Stop |
| 3. Rod | 8. Bearing | 13. O-Ring | 18. Wiper |
| 4. Piston | 9. Ring, Wear | 14. Ring, Backup | 19. Fitting, Straight |
| 5. Head | 10. Ring, Wear | 15. Ring, Backup | |

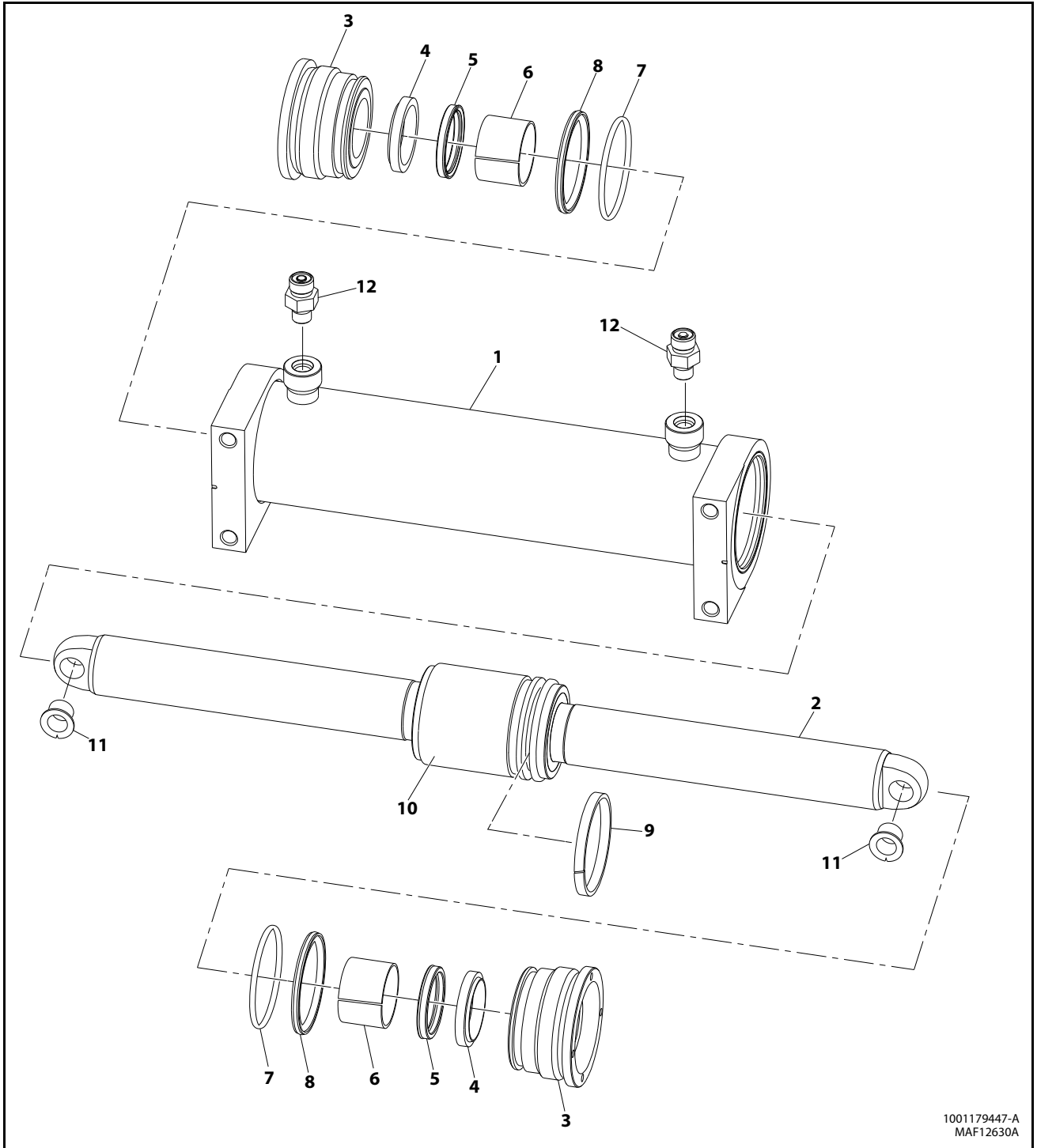

1001179447-A
MAF12630A

Figure 4-18. Steer Cylinder (R2632)

- | | | |
|-----------|----------------|----------------------|
| 1. Barrel | 5. Rod Seal | 9. Piston Seal |
| 2. Rod | 6. Wear Ring | 10. Spacer |
| 3. Head | 7. O-Ring | 11. Flange Bearing |
| 4. Wiper | 8. Backup Ring | 12. Straight Fitting |

4.14 CYLINDER REPAIR

NOTE: The following are general procedures that apply to the cylinders on this machine. Procedures that apply to a specific cylinder will be so noted.

Disassembly

NOTICE

DISASSEMBLY OF THE CYLINDER SHOULD BE PERFORMED ON A CLEAN WORK SURFACE IN A DIRT FREE WORK AREA.

1. Connect a suitable auxiliary hydraulic power source to the port block fitting in the manifold located on the cylinder.

WARNING

DO NOT FULLY EXTEND CYLINDER TO THE END OF STROKE. RETRACT CYLINDER SLIGHTLY TO AVOID TRAPPING PRESSURE.

2. Operate the hydraulic power source and extend the cylinder. Shut down and disconnect the power source. Adequately support the cylinder rod, if applicable.
3. If applicable, remove the cartridge-type holding valve and fittings from the cylinder port block. Discard o-rings.
4. Place the cylinder barrel into a suitable holding fixture.

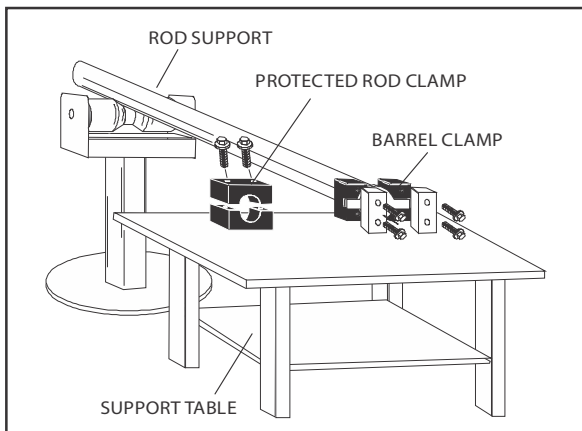

Figure 4-19. Cylinder Barrel Support

5. Mark cylinder head and barrel with a center punch for easy realignment. Loosen the cylinder head setscrew.

6. Using the proper wrench, loosen the cylinder head and remove head from cylinder barrel. When removing cylinder head do not force if binding occurs. Reverse rotation a couple times and try removing again. If still no release, tap barrel with hammer in threaded area, and try again. Repeat if necessary, until head is completely removed.
7. Attach a suitable pulling device to the cylinder rod port block end or cylinder rod end, as applicable.

NOTICE

EXTREME CARE SHOULD BE TAKEN WHEN REMOVING THE CYLINDER ROD, HEAD, AND PISTON. AVOID PULLING THE ROD OFF-CENTER, WHICH COULD CAUSE DAMAGE TO THE PISTON AND CYLINDER BARREL SURFACES.

8. With the barrel clamped securely, apply pressure to the rod pulling device and carefully withdraw the complete rod assembly from the cylinder barrel.

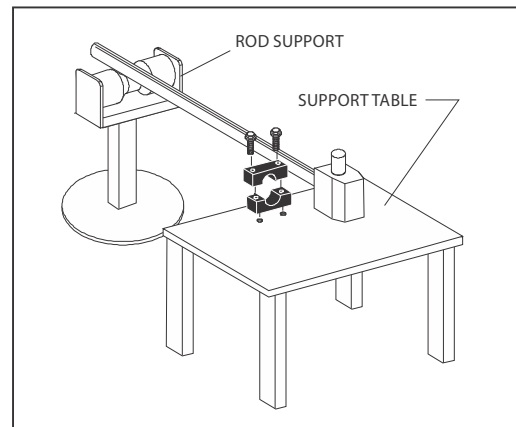

Figure 4-20. Cylinder Rod Support

9. Using suitable protection, clamp the cylinder rod in a vise or similar holding fixture as close to the piston as possible.
10. Loosen and remove the capscrew(s), if applicable, which attach the tapered bushing to the piston.
11. Insert the capscrew(s) in the threaded holes in the outer piece of the tapered bushing. Progressively tighten the capscrew(s) until the bushing is loose on the piston.
12. Remove the bushing from the piston.
13. Screw the piston CCW, by hand, and remove the piston from cylinder rod.
14. Remove and discard the piston o-rings, seal rings, and backup rings.

15. If applicable, remove the piston spacer from the rod.
16. Remove the rod from the holding fixture. Remove the cylinder head gland and retainer plate, if applicable. Discard the o-rings, backup rings, rod seals, and wiper seals.

Cleaning and Inspection

1. Clean all parts thoroughly in an approved cleaning solvent.
2. Examine the cylinder rod for scoring, tapering, ovality, or other damage. If necessary, dress rod with Scotch Brite or equivalent. Replace rod if necessary.
3. Examine threaded portion of rod for excessive damage. Dress threads as necessary.
4. Examine inner surface of cylinder barrel tube for scoring or other damage. Check inside diameter for tapering or ovality. Replace if necessary.
5. Examine threaded portion of barrel for damage. Dress threads as necessary.
6. Examine piston surface for damage and scoring and for distortion. Dress piston surface or replace piston as necessary.
7. Examine threaded portion of piston for damage. Dress threads as necessary.
8. Examine seal and o-ring grooves in piston for burrs and sharp edges. Dress applicable surfaces as necessary.
9. Examine cylinder head inside diameter for scoring or other damage and for ovality and tapering. Replace as necessary.
10. Examine threaded portion of head for damage. Dress threads as necessary.
11. Examine seal and o-ring grooves in head for burrs and sharp edges. Dress applicable surfaces as necessary.
12. Examine cylinder head outside diameter for scoring or other damage and ovality and tapering. Replace as necessary.

13. If applicable, Examine rod and barrel bearings for signs of correct excessive wear or damage. Replace as necessary.
 - a. Thoroughly clean hole, (steel bushing) of burrs, dirt etc. to facilitate bearing installation.
 - b. Examine steel bushing for wear or other damage. If steel bushing is worn or damaged, rod/barrel must be replaced.
 - c. Lubricate inside of steel bushing with WD40 prior to bearing installation.
 - d. Using an arbor of the correct size, carefully press the bearing into steel bushing.

NOTE: Install pin into the Gar-Max bearing dry. Lubrication is not required with nickel plated pins and bearings.

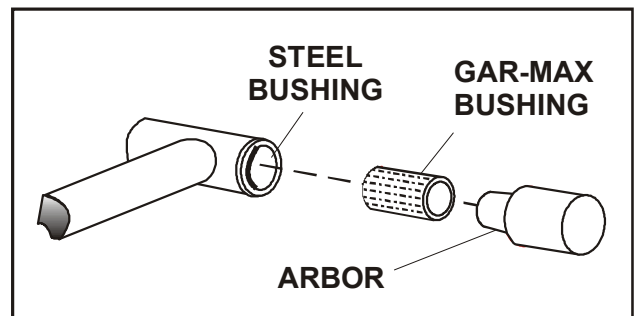

Figure 4-21. Gar-Max Bearing Installation

14. Examine travel limiting collar or spacer for burrs and sharp edges. If necessary, dress inside diameter surface with Scotch Brite or equivalent.
15. If applicable, examine port block fittings and holding valve. Replace as necessary.
16. Examine the oil ports for blockage or the presence of dirt or other foreign material. Repair as necessary.
17. If applicable, examine piston rings for cracks or other damage. Replace as necessary.

Assembly

NOTE: Prior to cylinder assembly, ensure that the proper cylinder seal kit is used. See your JLG Parts Manual for these machine models.

Apply a light film of hydraulic oil to all components prior to assembly.

1. A special tool is used to install a new rod seal into the applicable cylinder head gland groove.

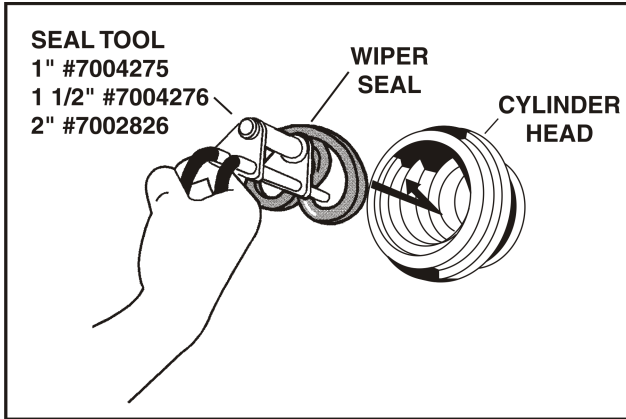

Figure 4-22. Rod Seal Installation

NOTICE

WHEN INSTALLING 'POLY-PAK' PISTON SEALS, ENSURE SEALS ARE INSTALLED PROPERLY. REFER TO WIPER SEAL INSTALLATION FOR CORRECT SEAL ORIENTATION. IMPROPER SEAL INSTALLATION COULD RESULT IN CYLINDER LEAKAGE AND IMPROPER CYLINDER OPERATION.

2. Use a soft mallet to tap a new wiper seal into the applicable cylinder head gland groove. Install a new wear ring into the applicable cylinder head glandgroove.

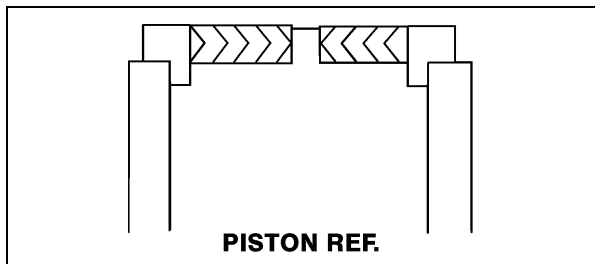

Figure 4-23. Poly-Pak Piston Seal Installation

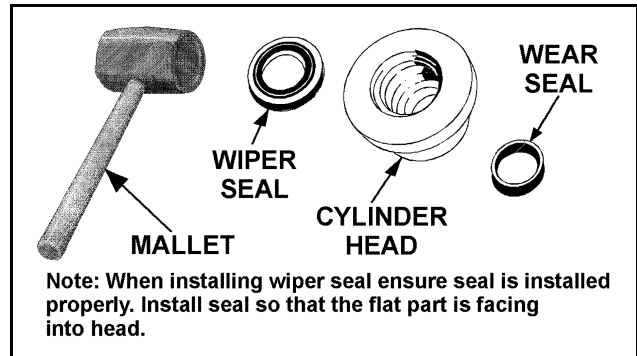

Figure 4-24. Wiper Seal Installation

3. Place a new o-ring and backup seal in the applicable outside diameter groove of the cylinder head.

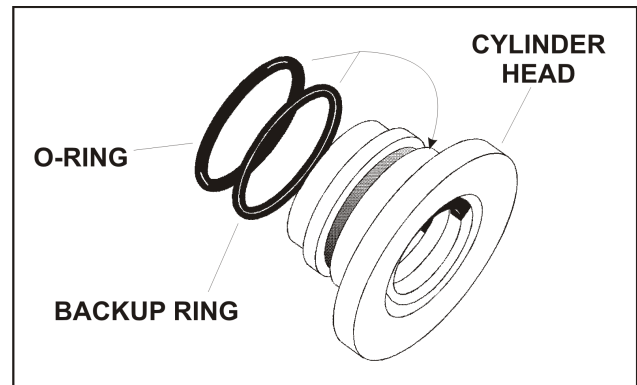

Figure 4-25. Installation of Head Seal Kit

4. Install washer ring onto rod, carefully install the head gland on the rod, ensuring that the wiper and rod seals are not damaged or dislodged. Push the head along the rod to the rod end, as applicable.
5. If applicable, correctly place new o-ring in the inner piston diameter groove. (The backup ring side facing the O-ring is grooved.)
6. If applicable, correctly place new seals and guide lock rings in the outer piston diameter groove. (A tube, with I.D. slightly larger than the O.D. of the piston is recommended to install the solid seal.)

NOTE: The backup rings for the solid seal have a radius on one side. This side faces the solid seal.(See magnified insert in Figure 4-9. The split of seals and backup rings are to be positioned so as not to be in alignment with each other.

7. Using suitable protection, clamp the cylinder rod in a vise or similar holding fixture as close to piston as possible.

8. Carefully thread the piston on the cylinder rod hand tight, ensuring that the o-ring and backup rings are not damaged or dislodged.
9. Thread the piston onto the rod until it abuts the spacer end and install the tapered bushing.

NOTE: When installing the tapered bushing, piston and mating end of rod must be free of oil.

10. Assemble the tapered bushing loosely into the piston and insert JLG capscrews (not vendor capscrews) through the drilled holes in the bushing and into the tapped holes in the piston.
11. Tighten the capscrews evenly and progressively in rotation to the specified torque value.
12. After the screws have been torqued, tap the tapered bushing with a hammer (16 to 24 oz.) and brass shaft (approximately 3/4 in. diameter) as follows;
 - a. Place the shaft against the cylinder rod and in contact with the bushing in the spaces between the capscrews.
 - b. Tap each space once; this means the tapered bushing is tapped 3 times as there are 3 spaces between the capscrews.
13. Retorque the capscrews evenly and progressively in rotation to the specified torque value.
14. Remove the cylinder rod from the holding fixture.
15. Place new guide locks and seals in the applicable outside diameter grooves of the cylinder piston.
16. Position the cylinder barrel in a suitable holding fixture.

NOTICE

EXTREME CARE SHOULD BE TAKEN WHEN INSTALLING THE CYLINDER ROD, HEAD, AND PISTON. AVOID PULLING THE ROD OFF-CENTER, WHICH COULD CAUSE DAMAGE TO THE PISTON AND CYLINDER BARREL SURFACES.

17. With the barrel clamped securely, and while adequately supporting the rod, insert the piston end into the barrel cylinder. Ensure that the piston loading o-ring and seal ring are not damaged or dislodged.

18. Continue pushing the rod into the barrel until the cylinder head gland can be inserted into the barrel cylinder.
19. Secure the cylinder head gland using the washer ring and socket head bolts.

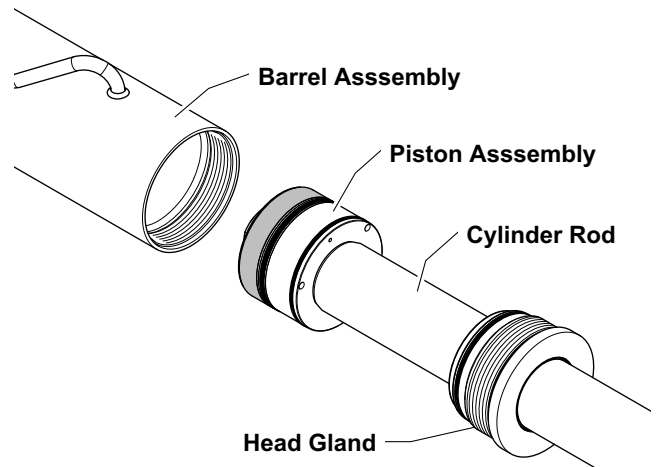

Figure 4-26. Rod Assembly Installation

20. After the cylinder has been reassembled, the rod should be pushed all the way in (fully retracted) prior to the re-installation of any holding valve or valves.
21. If applicable, install the cartridge-type holding valve and fittings in the rod port block, using new o-rings as applicable.
22. Push the piston onto the rod until it abuts the spacer end and install the attaching nut.

⚠ WARNING

WHEN REBUILDING THE CYLINDERS, APPLY MEDIUM - HIGH STRENGTH THREADLOCKING COMPOUND TO THE PISTON NUT, THEN TORQUE PISTON NUT. REFER TO APPLICABLE CYLINDER ILLUSTRATION FOR TORQUE REQUIREMENT.

23. Remove the cylinder rod from the holding fixture.
24. Position the cylinder barrel in a suitable holding fixture.

NOTICE

EXTREME CARE SHOULD BE TAKEN WHEN INSTALLING THE CYLINDER ROD, HEAD, AND PISTON. AVOID PULLING THE ROD OFF-CENTER, WHICH COULD CAUSE DAMAGE TO THE PISTON AND CYLINDER BARREL SURFACES.

25. With barrel clamped securely, and while adequately supporting the rod, insert the piston end into the barrel cylinder. Ensure that the piston loading o-ring and seal ring are not damaged or dislodged.

26. Continue pushing the rod into the barrel until the cylinder head gland can be inserted into the barrel cylinder.
27. If applicable, secure the cylinder head retainer using a suitable chain wrench.
28. After the cylinder has been reassembled, the rod should be pushed all the way in (fully retracted) prior to the re-installation of any holding valve or valves.
29. If applicable, install the cartridge-type holding valve and fittings in the port block using new o-rings as applicable. Refer Figure 4-16., Lift Cylinder on page 4-21.

4.15 HYDRAULIC SCHEMATICS

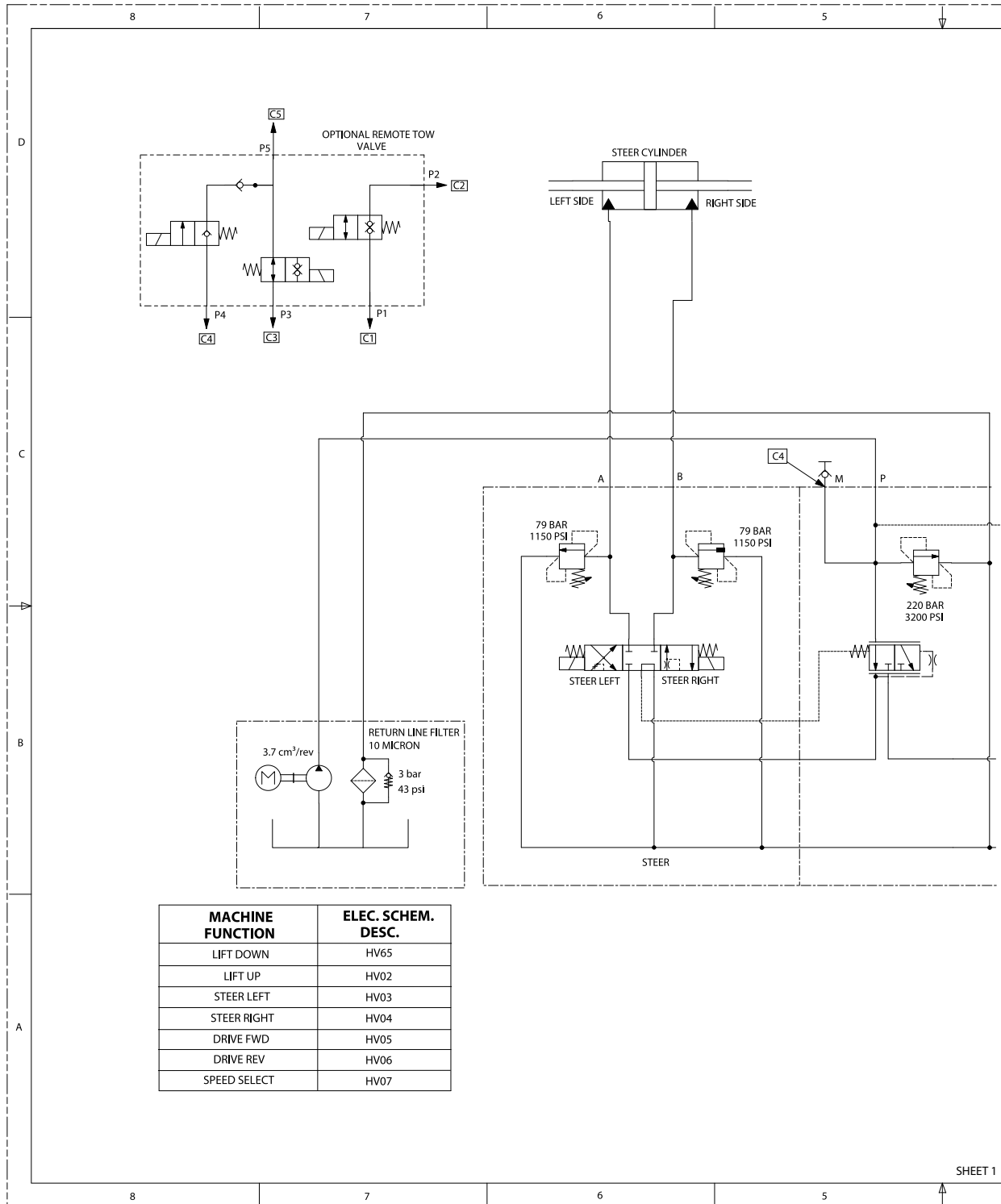

Figure 4-27. Hydraulic Schematic (R3246) - Sheet 1 of 2

SECTION 4 - BASIC HYDRAULICS INFORMATION & SCHEMATICS

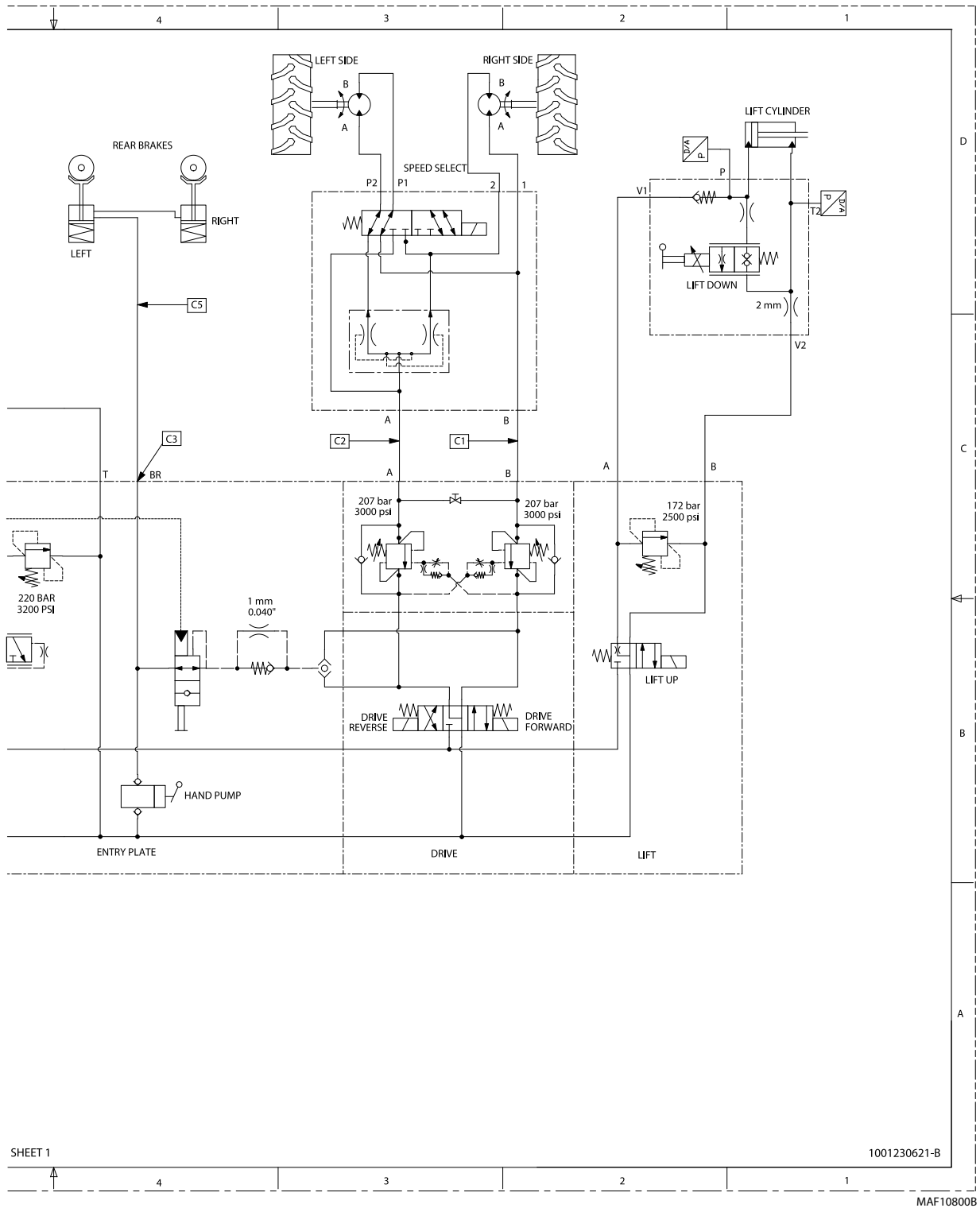

Figure 4-28. Hydraulic Schematic (R3246) - Sheet 2 of 2

SECTION 4 - BASIC HYDRAULICS INFORMATION & SCHEMATICS

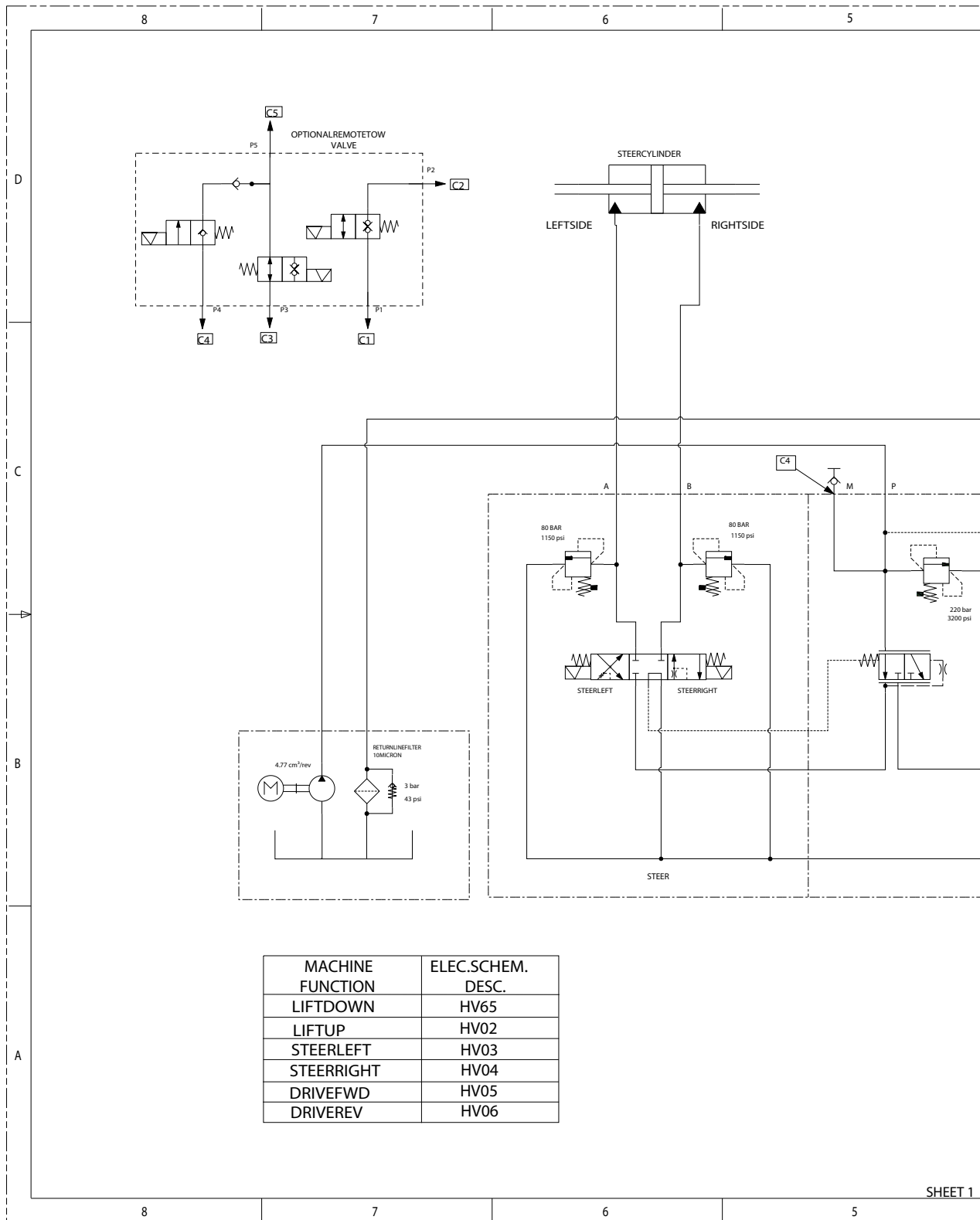

Figure 4-29. Hydraulic Schematic (R2632) - Sheet 1 of 2

SECTION 4 - BASIC HYDRAULICS INFORMATION & SCHEMATICS

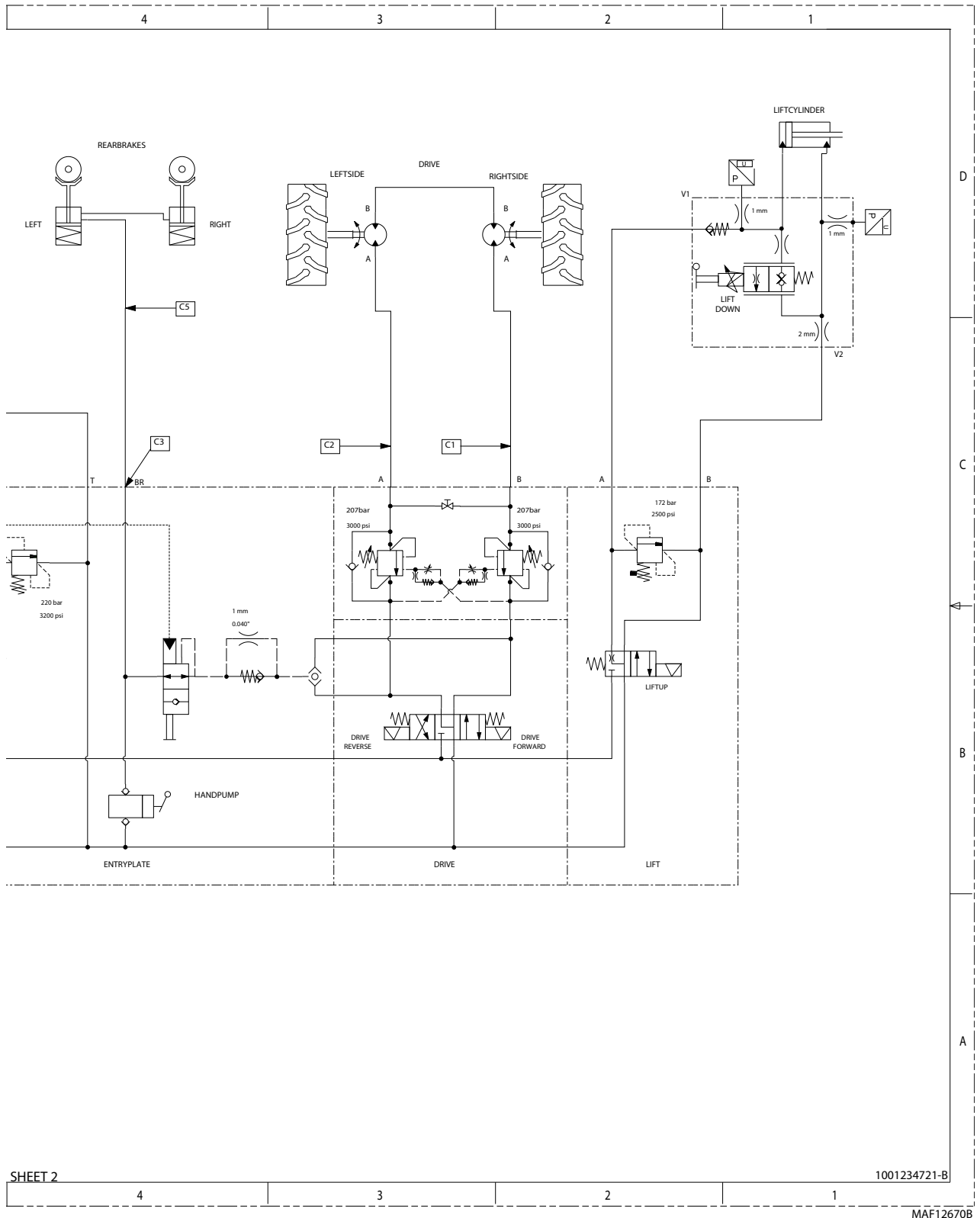

Figure 4-30. Hydraulic Schematic (R2632) - Sheet 2 of 2

SECTION 5. JLG CONTROL SYSTEM

5.1 HAND HELD ANALYZER

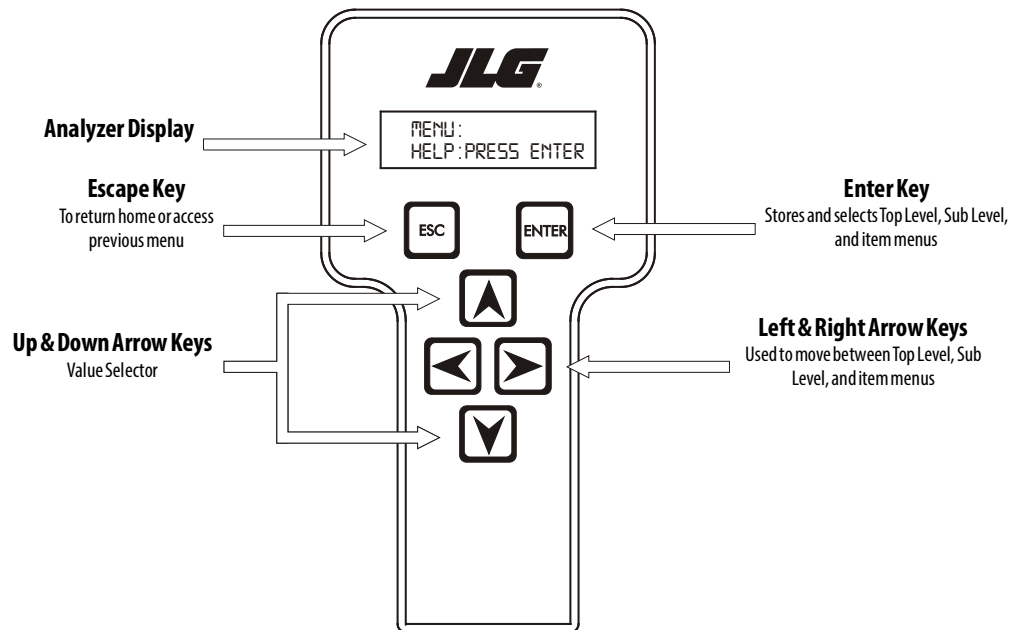

Figure 5-1. Hand Held Analyzer

Diagnostic Port

To connect the Hand Held Analyzer, the diagnostic port plug (1) is located in chassis harness close to the hydraulic valve manifold (2), and machine controller logic module (3), inside the right side compartment door, as shown in Figure 5-2.

To Connect the Hand Held Analyzer:

1. Connect the four pin end of the cable supplied with the analyzer, to the diagnostic port plug and connect the remaining end of the cable to the analyzer.

NOTE: The cable has a four pin connector at each end of the cable; the cable cannot be connected backwards.

2. Power up the control system by turning the ground control station - platform/ground selector switch - to the platform position and pulling both platform and ground control emergency stop buttons on.

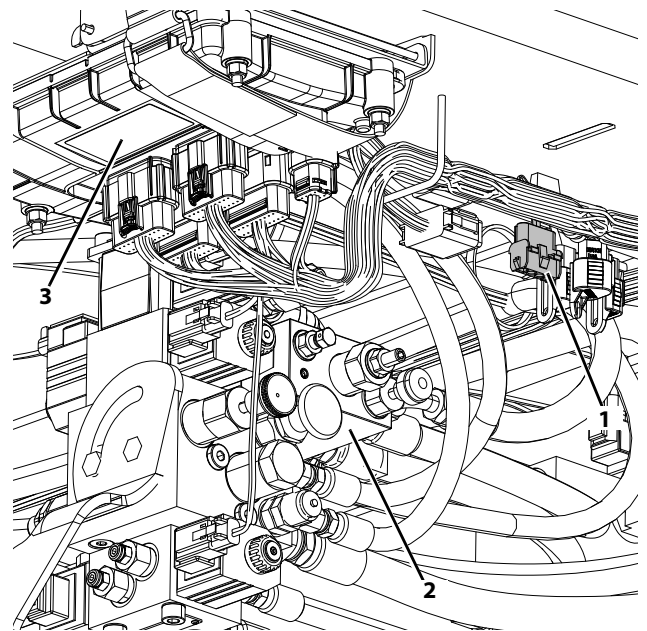

MAF10120

1. Diagnostic Port Plug
2. Hydraulic Valve Manifold
3. Controller Logic Module

Figure 5-2. Diagnostic Port Location
(Inside right side compartment door)

Using the Analyzer:

With the machine power on and the analyzer connected properly, the analyzer will display the following:

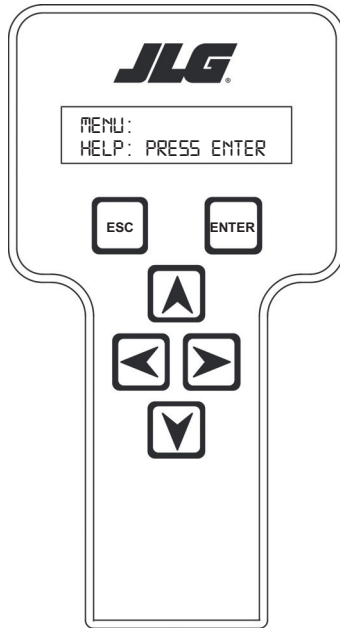

**HELP:
PRESS ENTER**

At this point, using the **RIGHT** and **LEFT** arrow keys, you can move between the top level menu items. To select a displayed menu item, press **ENTER**. To cancel a selected menu item, press **ESC**; then you will be able to scroll using the right and left arrow keys to select a different menu item.

The top level menus are as follows:

- HELP**
- DIAGNOSTICS**
- SYSTEM TEST**
- ACCESS LEVEL**
- PERSONALITIES**
- MACHINE SETUP**
- CALIBRATION**

If you press **ENTER**, at the HELP: PRESS ENTER display, and a fault is present, the analyzer display will scroll the fault across the screen. If more than one fault is present only the highest priority fault will show. The other active faults are viewable in Logged Help. If there was no fault detected, the display will read:

In platform mode,
**HELP: (001)
EVERYTHING OK,**

In ground mode,
**HELP: (002)
GROUND MODE OK**

If **ENTER** is pressed again, the display moves to the following display:

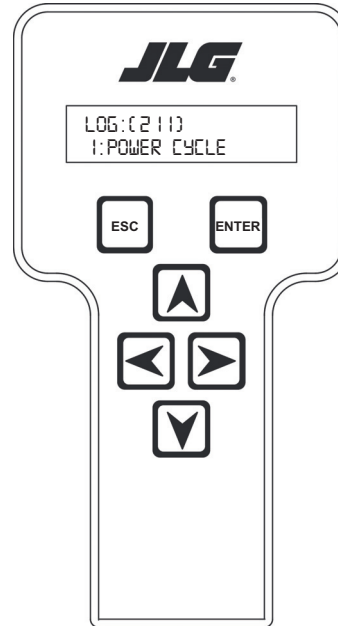

**LOG: (211)
1: Power Cycle (Or last recorded fault)**

At this point, the analyzer will display the highest priority active fault, if any are present. You may scroll through the fault logs to view what the last fifteen faults were. Use the right and left arrow keys to scroll through the fault logs. The active faults, are listed before the first POWER CYCLE. To return to the top menu, press **ESC** two times.

When a top level menu is selected, a new set of menu items may be offered; If for example you choose Personalities:

- DRIVE**
- LIFT**
- STEER**
- GROUND**

Pressing **ENTER** with any of the above displayed menus, will display additional sub-menus within the selected menu. In some cases the next level is the parameter or information to be changed. Refer to the flow chart for what menus are available within the top level menus. You may only view the personality settings for selected menus while in access level 2. Remember, you may always cancel a selected menu item by pressing the **ESC** key.

Changing the Access Level of the Hand Held Analyzer:

Analyzer:

When the analyzer is first connected, you will be in access level 2 which enables you to only view most configuration settings which cannot be changed until you enter a password to advance to a lower level. This ensures that a setting cannot be accidentally altered. To change the access level, the correct password must be entered. To enter the password, scroll to the **ACCESS LEVEL** menu.

For example:

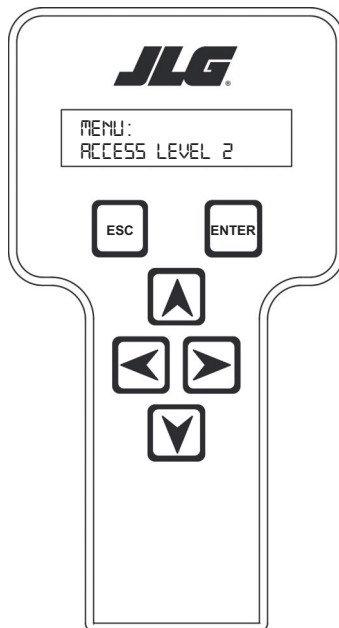

MENU:
ACCESS LEVEL 2

Press **ENTER** to select the **ACCESS LEVEL** menu. Using the **UP** or **DOWN** arrow keys, enter the first digit of the password, 3. Then using the **RIGHT** arrow key, position the cursor to the right one space to enter the second digit of the password. Use the **UP** or **DOWN** arrow key to enter the second digit of the password which is 3. Repeat this process until you have entered all five digits of the password which is **33271**. Once the correct password is displayed, press **ENTER**. The access level should display the following, if the password was entered correctly:

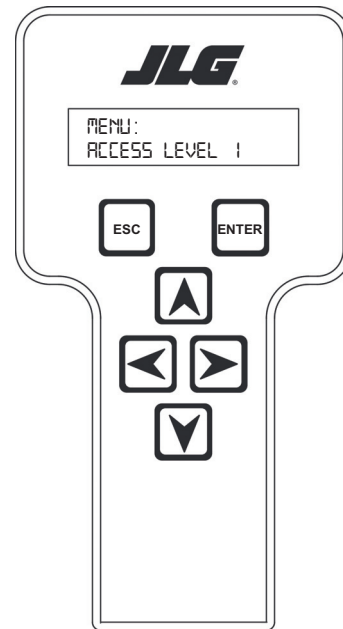

MENU:
ACCESS LEVEL 1

Repeat the above steps if the correct access level is not displayed or you can not adjust the personality settings:

Adjusting Parameters Using the Hand Held Analyzer

Once you have gained access to level 1, and a personality item is selected, press the UP or DOWN arrow keys to adjust its value, for example:

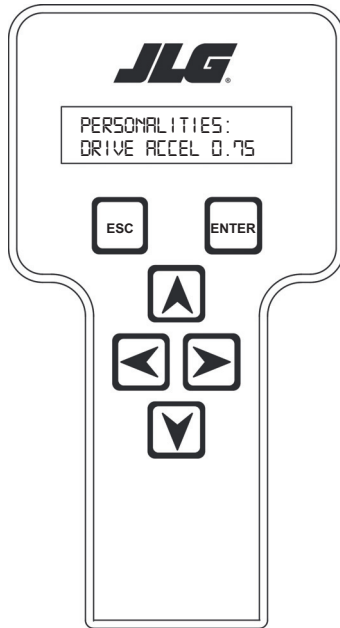

**PERSONALITIES:
DRIVE ACCEL 0.75**

There will be a minimum and maximum for the value to ensure efficient operation. The Value will not increase if the **UP** arrow is pressed when at the maximum value nor will the value decrease if the **DOWN** arrow is pressed and the value is at the minimum value for any particular personality. If the value does not change when pressing the up and down arrows, check the access level to ensure you are at access level 1.

Machine Setup

When a machine digit item is selected, press the **UP** or **DOWN** arrow keys to adjust its value, for example:

⚠ WARNING

FAILURE TO MAKE THE PROPER SETTINGS FOR THE PARTICULAR MACHINE CAN RESULT IN IMPROPER OPERATION.

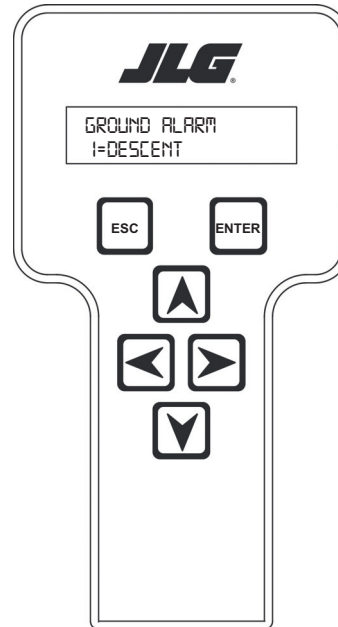

**GROUND ALARM:
1=DESCENT**

The effect of the machine digit value is displayed along with its value. The above display would be selected if the machine was equipped with a ground alarm and you wanted it to sound when driving. There are certain settings allowed to install optional features or select the machine model.

When selecting the machine model to match the size of the machine, the personality settings will return to default settings.

NOTE: Refer to Table 5-2, Machine Model Adjustment (Software Version P1.13.1) and Table 5-1, Machine Configuration Programming Information (Software Version P1.13.1) for the default settings.

Password 33271 will give you access to level 1, which will permit you to change all machine personality and/or machine setup settings.

⚠ WARNING

CHANGING THESE SETTINGS MAY ADVERSELY AFFECT THE PERFORMANCE OF YOUR MACHINE.

5.2 JOYSTICK CALIBRATION

The joystick calibration should be completed if the joystick is replaced. To perform the joystick calibration both emergency stop switches must be pulled out (reset) and the ground control keyswitch set on platform mode.

1. Plug the analyzer into the machine, "Help Press Enter" should be displayed on the analyzer display.
2. Press the right arrow key to "Access Level 2".
3. Press Enter once. At this screen, you are asked to enter a password: Enter "33271" by doing the following:
 - a. Using the up and down key enter the first number.
 - b. Right arrow key once and enter the next number.
 - c. Repeat steps A and B until you have entered "33271" and press Enter.
 - d. Access level 1 should be on the display.
4. Press right arrow key to "Calibrations" and press Enter once.
5. "Calibration: Joystick" should appear, press Enter once.
6. "Cal Joystick: Yes: Enter, No: Esc" should appear, press Enter once.
7. "Cal Joystick: Fwd to Max" will appear. Move joystick completely forward and hold, then press Enter.
8. "Cal Joystick: Center" will appear. Release joystick to the neutral position and press Enter.
9. "Cal Joystick: Rev to Max" will appear. Move joystick completely in the reverse position and hold, then press Enter.
10. "Cal Joystick: Complete" will appear. Power down the machine.

5.3 TILT SENSOR CALIBRATION

Be sure that the machine is parked and stowed on level ground.

NOTE: *Tilt Sensor Calibration can not be performed if the main contactor switch is open due to an alarm.*

1. Enter Access Level 1 and go to the CALIBRATION/TILT SENSOR/LEVEL VEHICLE screen.
2. Choose the right arrow key to view the raw, uncalibrated tilt sensor values. If either raw angle reads ± 5.0 or more, the machine is too unlevel and the software will prohibit calibration. Therefore, attempt to dissect the three areas of error to find the primary contributor:
 - a. Machine mounting and/or grade:
 - Try to measure the top of the tilt sensor for levelness. If unable to get a good reading, unbolt the tilt sensor and check the sensor's mounting surface for levelness.
 - b. Observe whether the tilt sensor is properly seated.
 - c. Tilt sensor has developed an offset shift:
 - Keep the tilt sensor electrically connected. Level one axis of the tilt sensor and observe the raw reading (should be within ± 2.0). Do the same for the other axis. If either axis is greater than ± 2.0 , replace the tilt sensor.

NOTE: *Check that the tilt switch is properly set by referring to the Tilt Activation Settings table in Section 1 of this manual.*

Tilt Sensor Failure Troubleshooting

Some possible reasons that the tilt sensor will not calibrate are:

- a. The surface the machine is sitting on is off level by a few degrees (flat doesn't imply level; parking lots are often not level).
- b. The tilt sensor has failed one or both of the channels (X axis and Y axis).
- c. Tilt sensor has moisture intrusion that has shifted its output.
- d. Water and/or corrosion in the sensor has corrupted electrical connections or caused a tilt sensor failure (observe any cracks in the housing).

For the following troubleshooting steps, a bubble level (smaller is better) will be needed and the machine must be on a level surface:

1. If the Analyzer displays angles other than +20.0°, attempt to calibrate. If machine won't calibrate, note the reason displayed on Analyzer:
 - a. SENSOR FAILURE – tilt sensor internal frequency is out of range (replace sensor).
 - b. NOT LEVEL - tilt sensor has either developed an offset or it is too unlevel as mounted on the machine.

5.4 ROTARY ANGLE SENSOR CALIBRATION

NOTICE

MACHINE MUST BE ON LEVEL GROUND BEFORE ELEVATION SENSOR CAN BE SET.

1. Be sure that the machine is parked and platform stowed on level ground.
2. Attach the analyzer near the ground control station.
3. Go to Access Level 1 and scroll through to CALIBRATION.
4. Under CALIBRATION, go to SET STOW ELEV.
5. Press ENTER for YES to set the stowed height for the elevation sensor.
6. Fully raise the platform.
7. Under CALIBRATION, go to SET MAX ELEV.
8. Press ENTER for YES to set the maximum height for the elevation sensor.

NOTE: *Check the sensor by lifting the scissor arms, from the platform, and driving until the drive speed cuts back. Refer to High Drive Speed Cutout Table in Section 1 for proper speed cut out height.*

5.5 UPDATING SOFTWARE

Software updates are available via OLE (Online Express). Navigate to the website and follow the instructions for to download software updates.

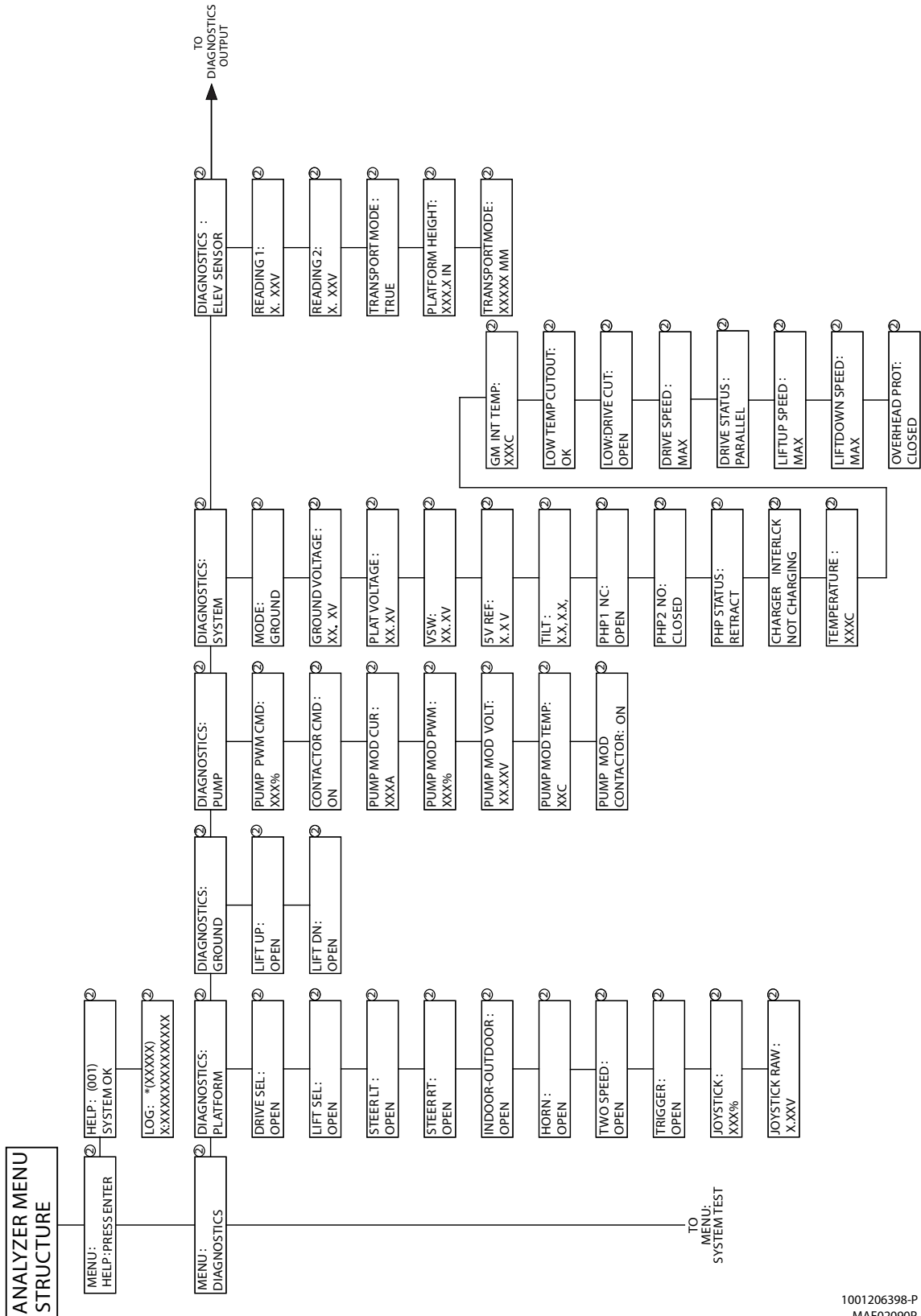

Figure 5-3. Analyzer Menu - Help and Diagnostics (Version P1.13.1) - Sheet 1 of 6

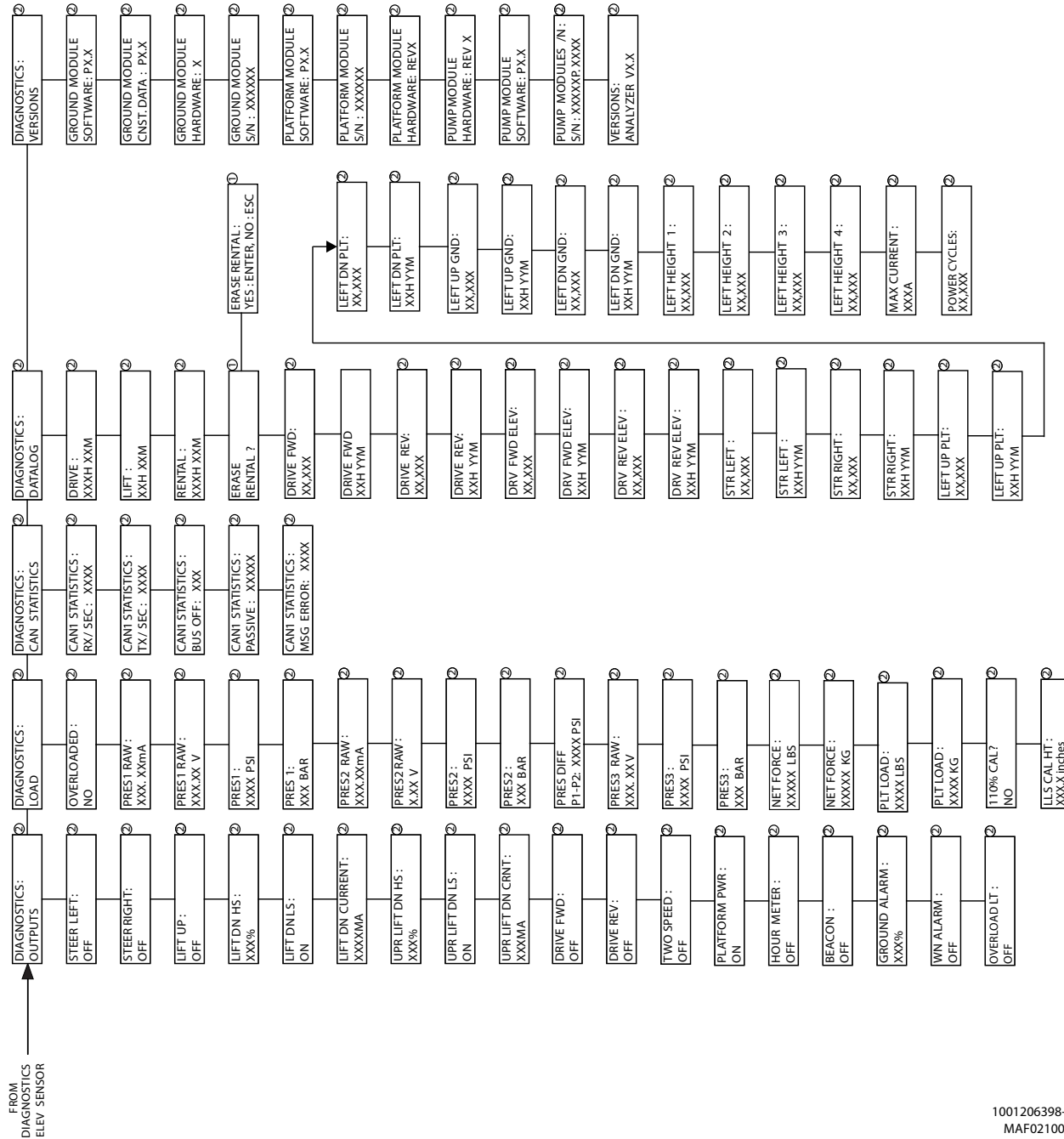
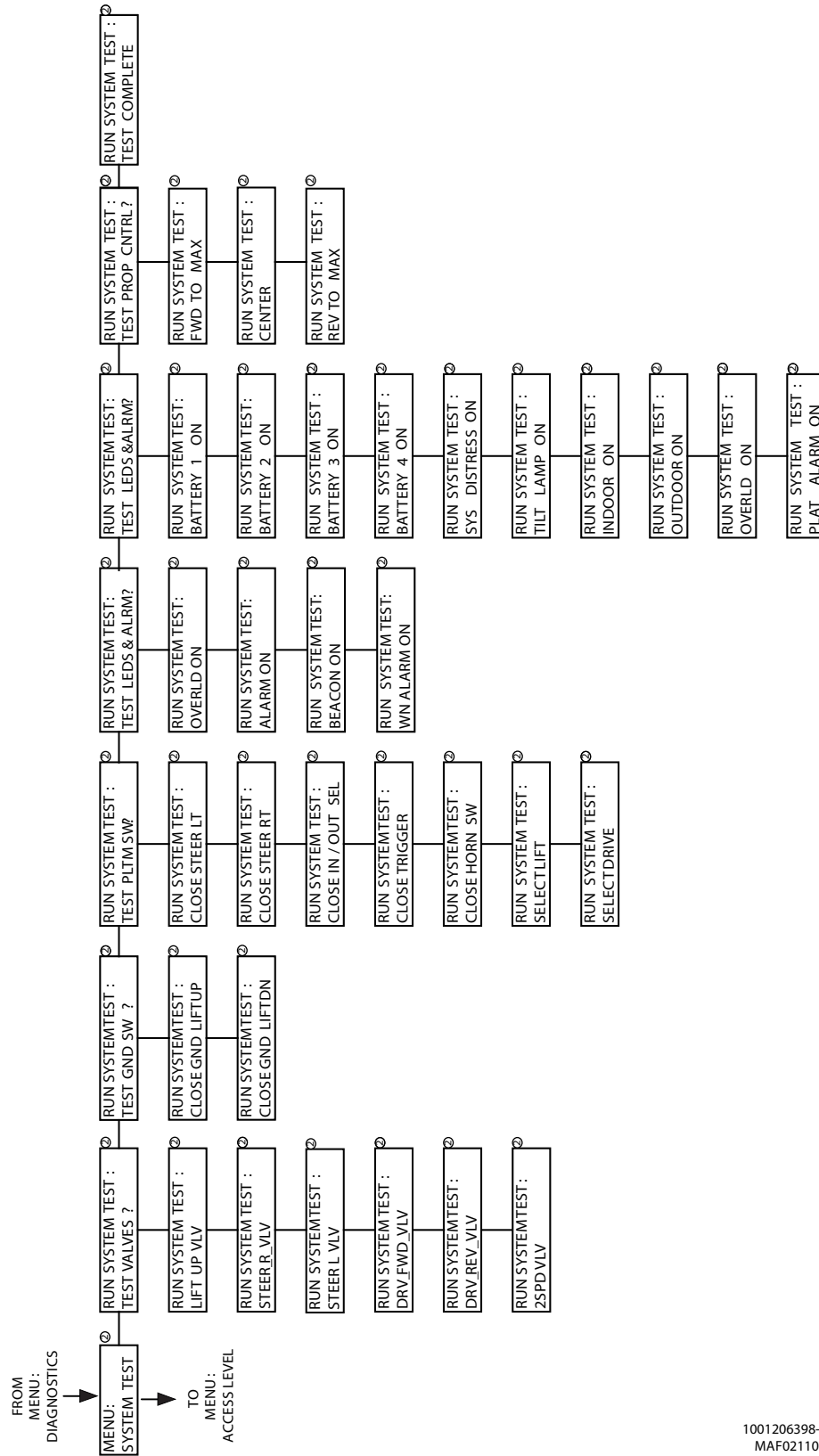

Figure 5-4. Analyzer Menu - Help and Diagnostics (Version P1.13.1) - Sheet 2 of 6

1001206398-P
MAF02100P



1001206398-P
MAF02110P

Figure 5-5. Analyzer Menu - Help and Diagnostics (Version P1.13.1) - Sheet 3 of 6

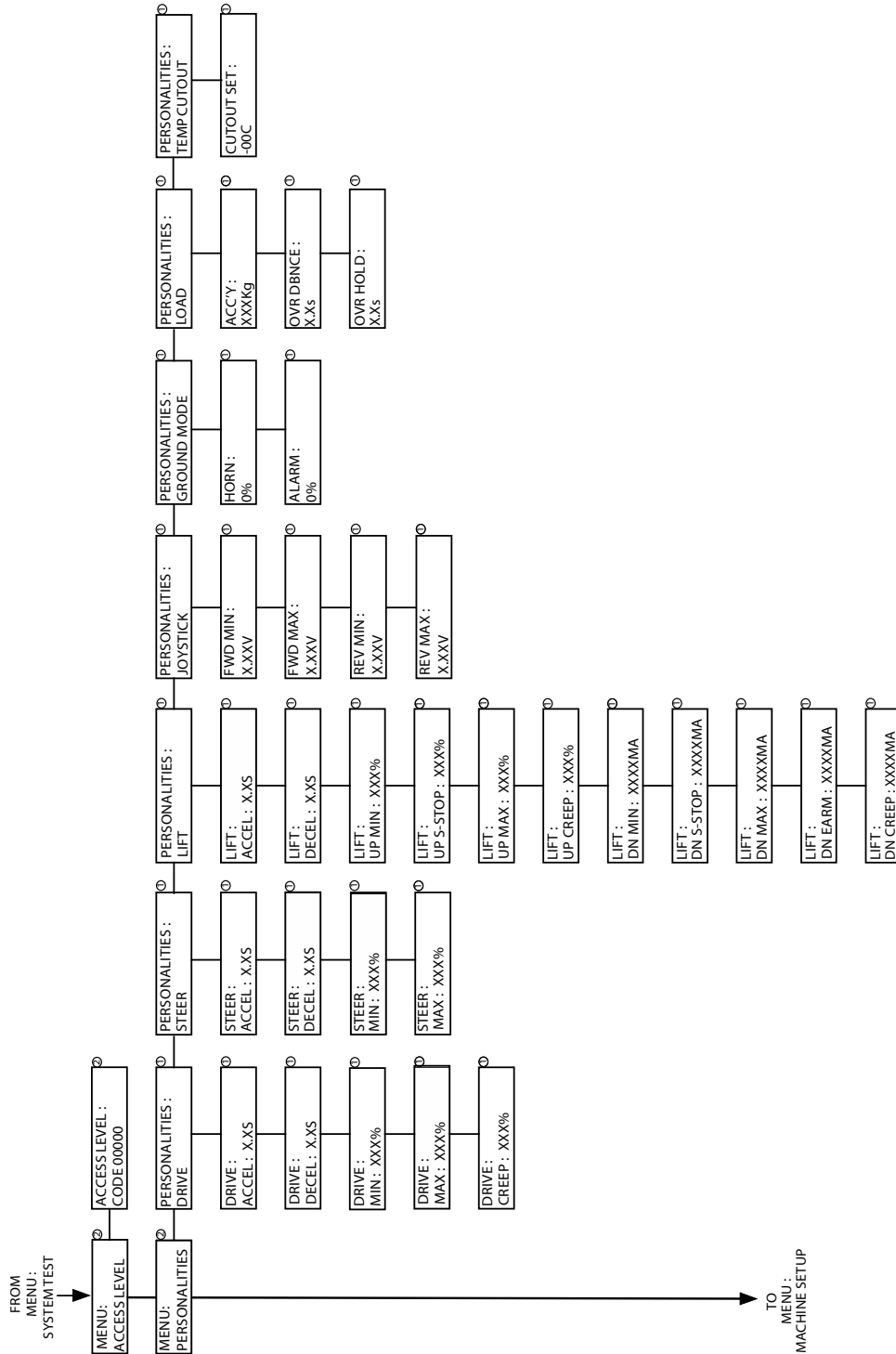

1001206398-P
MAF02120P

Figure 5-6. Analyzer Menu - Help and Diagnostics (Version P1.13.1) - Sheet 4 of 6

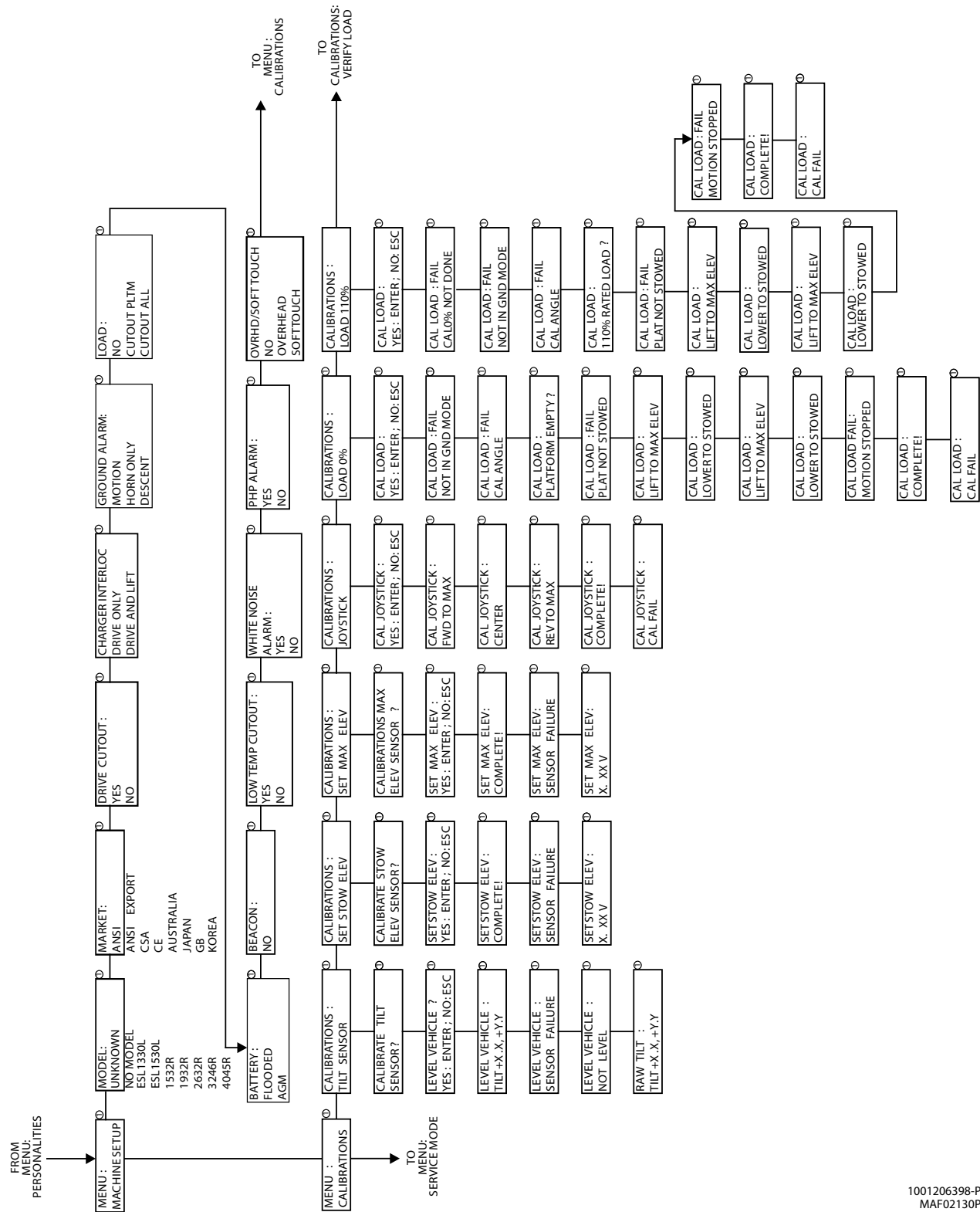

Figure 5-7. Analyzer Menu - Help and Diagnostics (Version P1.13.1) - Sheet 5 of 6

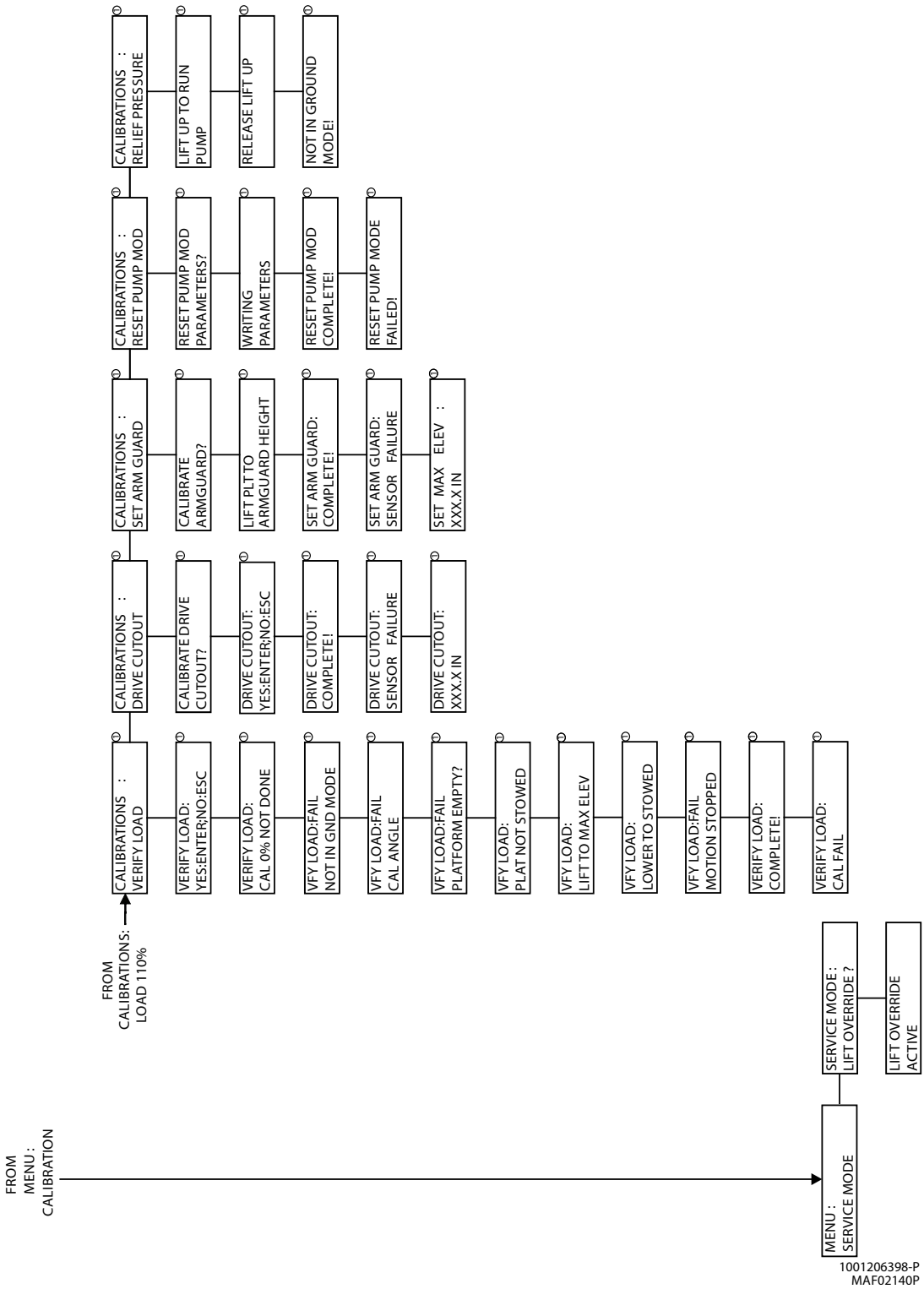

Figure 5-8. Analyzer Menu - Help and Diagnostics (Version P1.13.1) - Sheet 6 of 6

5.6 MACHINE CONFIGURATION PROGRAMMING INFORMATION

NOTE: 1. When configuring a R scissors machine, the Machine Configuration must be completed before any Personality settings can be changed, see Table 5-2. Changing the personality settings first and then changing the model number of the machine configuration will cause the personality settings to return to default.

2. Solid shaded entries are not available for the selected Market.

Table 5-1. Machine Configuration Programming Information (Software Version P1.13.1)

Configura- tion Digit	Setting	Description	Market Default Setting							
			1	2	3	4	5	6	7	8
MODEL	1	2632R, R2632								
	2	3246R, R3246								
	3	1932R, R1932, R1932i	1	1	1	1	1	1	1	1
	4	1532R, R1532i								
	5	4045R, R4045								
MARKET	1	ANSI USA								
	2	ANSI EXPORT								
	3	CSA								
	4	CE								
	5	AUSTRALIA	1	1	1	1	1	1	1	1
	6	JAPAN								
	7	GB								
	8	KOREA								
DRIVE CUTOUT	1	NO - Vehicle is not configured with Drive cutout when elevated.								
	2	YES - Vehicle is configured with Drive cutout when elevated.	1	1	1	1	1	1	1	1
CHARGER INTERLOCK	1	DRIVE ONLY - Drive motion prevented while vehicle is charging.								
	2	DRIVE AND LIFT UP - Drive and lift up motions are prevented while vehicle is charging.	1	1	1	1	1	1	1	1
GROUND ALARM	1	MOTION - Ground Alarm sounds during Lift Up, Lift Down, Drive Forward, or Drive Reverse.								
	2	HORN ONLY - Ground Alarm only sounds when user presses Platform Horn button.	1	1	1	2	1	1	2	1
	3	DESCENT - Ground Alarm sounds during Lift Down.								
LOAD	1	NO - Load Sensing System (LSS) is not fitted to the vehicle.								
	2	CUTOUT PLATFORM - Load Sensing System (LSS) is fitted, and Platform Controls are prevented in the event of an Overload. Ground Controls remain functional.	2	2	2	3	2	2	3	2
	3	CUTOUT ALL - Load Sensing System (LSS) is fitted. Platform and Ground Controls are prevented in the event of an Overload.								
BATTERY	1	FLOODED - Batteries are conventional lead-acid type.								
	2	AGM - Batteries are absorbed glass mat type.	1	1	1	1	1	1	1	1
BEACON	1	YES - Optional beacon is present.								
	2	NO - Optional beacon not present.	2	2	2	1	2	2	1	2
LOW TEMP CUTOUT	1	YES - Low temp cutout is active.								
	2	NO - Low temp cutout is not active.	2	2	2	2	2	2	2	2
WHITE NOISE ALARM	1	NO - Vehicle does not have the white noise alarm.								
	2	YES - Vehicle has the white noise alarm.	1	1	1	1	2	1	1	1
PHP ALARM	1	NO - Vehicle is not configured with PHP Alarm when Pothole bar is blocked.								
	2	YES - Vehicle is configured with PHP Alarm when Pothole bar is blocked.	1	1	1	1	1	1	1	1
OVERHEAD PROTECT	1	NO - Vehicle is not configured with Overhead Protection Sensors.								
	2	YES - Vehicle is configured with Overhead Protection Sensors.	1	1	1	1	1	1	1	1

1001207563-G

5.7 MACHINE MODEL ADJUSTMENT (PERSONALITY SETTINGS)

Table 5-2. Machine Model Adjustment (Software Version P1.13.1)

Adjustment	Adjustment Range	R2632	R3246
DRIVE			
ACCEL	0.1-5.0(Sec)	1.5	1.5
DECEL	0.1-2.0(Sec)	0.5	0.5
MINIMUM	1-25%	8	8
MAXIMUM	26-100%	100	100
ELEV. MAXIMUM	0-50%	28	43
STEER			
ACCEL	0.1-5.0(Sec)	0.1	0.1
DECEL	0.1-1.0(Sec)	0.3	0.3
MIN	1-25%	5	5
MAX	26-100%	60	60
LIFT			
ACCEL	0.1-5.0(Sec)	0.7	0.7
DECEL	0.1-1.0(Sec)	0.1	0.1
UP MIN	1-45%	20	20
UP STOP	1-100%	55	70
UP MAX	31-100%	69	100
UP CREEP	1-100%	50	50
DOWN MIN	250-350mA	280	350
DOWN S-STOP	250-1200mA	450	470
DOWN MAX	351-1200mA	1040	1040
DOWN EARM	250-1200mA	370	470
DOWN CREEP	250-1200mA	370	470
JOYSTICK			
FWD MIN	1.95-2.45V	2.20	2.20
FWD MAX	0.94-1.44V	1.19	1.19
REV MIN	2.59-3.09V	2.84	2.84
REV MAX	3.53-4.03V	3.78	3.78
GROUND			
HORN	1-100%	94	94
ALARM	1-100%	25	25
LOAD			
OVERLOAD DEBOUNCE	0.0-5.0s	0.3s	0.3s
OVERLOAD HOLD	0.0-5.0s	5.0s	5.0s
ACC'Y	0-200KG	0	0
TEMP CUTOUT			
CUTOUT SET	-18-0C	-18	-18

1001207564-J

NOTE: These settings may be changed in order to achieve optimal performance.

SECTION 6. LSS (LOAD SENSING SYSTEM) SERVICE

6.1 LSS (LOAD SENSING SYSTEM)

Theory of Operation

The Load Sensing System (LSS) is designed to measure platform load and prevent overload situations. The system consists of pressure sensors on the lift cylinder, an elevation angle sensor, and the control module.

For vehicles with a single lift cylinder, a dual-channel pressure sensor with current output is mounted on the lift cylinder to measure head pressure. The primary feedback is scaled 0-3626 PSI as 4-20 mA. The backup feedback is scaled 0-3626 PSI as 20-4 mA. A single channel pressure with voltage output is mounted on the lift cylinder to measure rod pressure. The rod feedback is scaled 0-1450PSI as 0.5-4.5V. The pressures are combined with geometric information about the lift cylinder to calculate the net lift cylinder force. The primary and backup channels of the lift cylinder head pressure transducer are continuously compared to detect sensor integrity issues.

The elevation angle sensor is used to estimate platform height based on lower arm angle. The calibration process teaches the control system the feedback voltage for the stowed and fully elevated positions. The feedback voltage and calibration information are combine with geometric information to calculate the platform height.

The LSS can be calibrated in the field without test weights using the procedure within the CALIBRATIONS ' LOAD 0% menu. The procedure allows the control system to measure net lift cylinder force at a variety of platform heights while lifting up and down with an empty platform. Once the force profile is validated, the control system uses geometric information to calculate the remaining calibration information for a loaded platform. Vehicles calibrated with this method may experience a slight capacity reduction (10% to 20%) but remain regulatory compliant. The control system will flash the Ground Overload Indicator twice at power-up to indicate LSS has been calibrated without test weights (refer to DIAGNOSTICS ' LOAD ' 110% CAL).

The LSS can be calibrated to maximum accuracy in the service center with test weights using the procedure within the CALIBRATIONS ' LOAD 110% menu. This procedure should be executed after CALIBRATIONS ' LOAD 0%. The procedure allows the control system to replace the calculated calibration information with measured net lift cylinder forces while lifting up and down with a loaded platform.

If the vehicle must be calibrated in a situation with restrictive ceiling height, the LSS will accept a partial height calibration. The platform should be lifted as close

as practical to the ceiling when prompted to LIFT TO MAX ELEV. The control system will automatically restrict lift up to the demonstrated platform height until the system is re-calibrated to full height in the future.

The LSS can be periodically verified without test weights to extend calibration intervals. The procedure within the CALIBRATIONS ' VERIFY LOAD menu allows the control system to confirm net lift cylinder forces against calibration information at a variety of platform heights while lifting up and down with an empty platform. The control system will indicate PASS if the measured forces compare within a tight tolerance to the calibration information, and FAIL otherwise. Verification automatically restricts lift up if the vehicle is calibrated in a situation with restrictive ceiling height.

During operation, the control system measures platform load while platform height is 10% to 90% of maximum height. The system functions in this manner to avoid abnormalities caused by deployment of the Pot-Hole system and maximum extension of the lift cylinder.

The control system provides a mechanism to ignore instantaneous changes in friction and avoid spurious overloads. Measured platform load must be greater than the capacity limit for a period that exceeds the PERSONALITIES ' LOAD ' OVR DBNCE (seconds) setting before the LSS indicates an overload. Once an overload has occurred, measured platform load must be less than the capacity limits for a period that exceeds the PERSONALITIES ' LOAD ' OVR HOLD (seconds) setting before the LSS indicates no overload.

Accessories mounted in the platform have an impact on the LSS capacity limit. The PERSONALITY ' LOAD ' ACC'Y (KG) setting is used to account for accessories by reducing the capacity limit. The control system will manage accessories properly when the LOAD ' ACC'Y setting is adjusted prior to LSS calibration according to the documentation furnished with the factory-provided accessories. Light-weight accessories like optional lighting or foot-switches do not impact the LSS capacity limit and the LOAD ' ACC'Y setting should be set to zero. Accessories like the Electrician's Tree reduce the LSS capacity limit according to their weight and the LOAD ' ACC'Y setting must be set to account for their total weight. Finally, accessories like the Panel Carrier induce wind loading on the vehicle and reduce the LSS capacity limit by more than their weight and the LOAD ' ACC'Y setting must be to the values recommended by JLG. Follow the documentation furnished with factory-provided accessories when fitting more than one accessory to a vehicle or consult JLG.

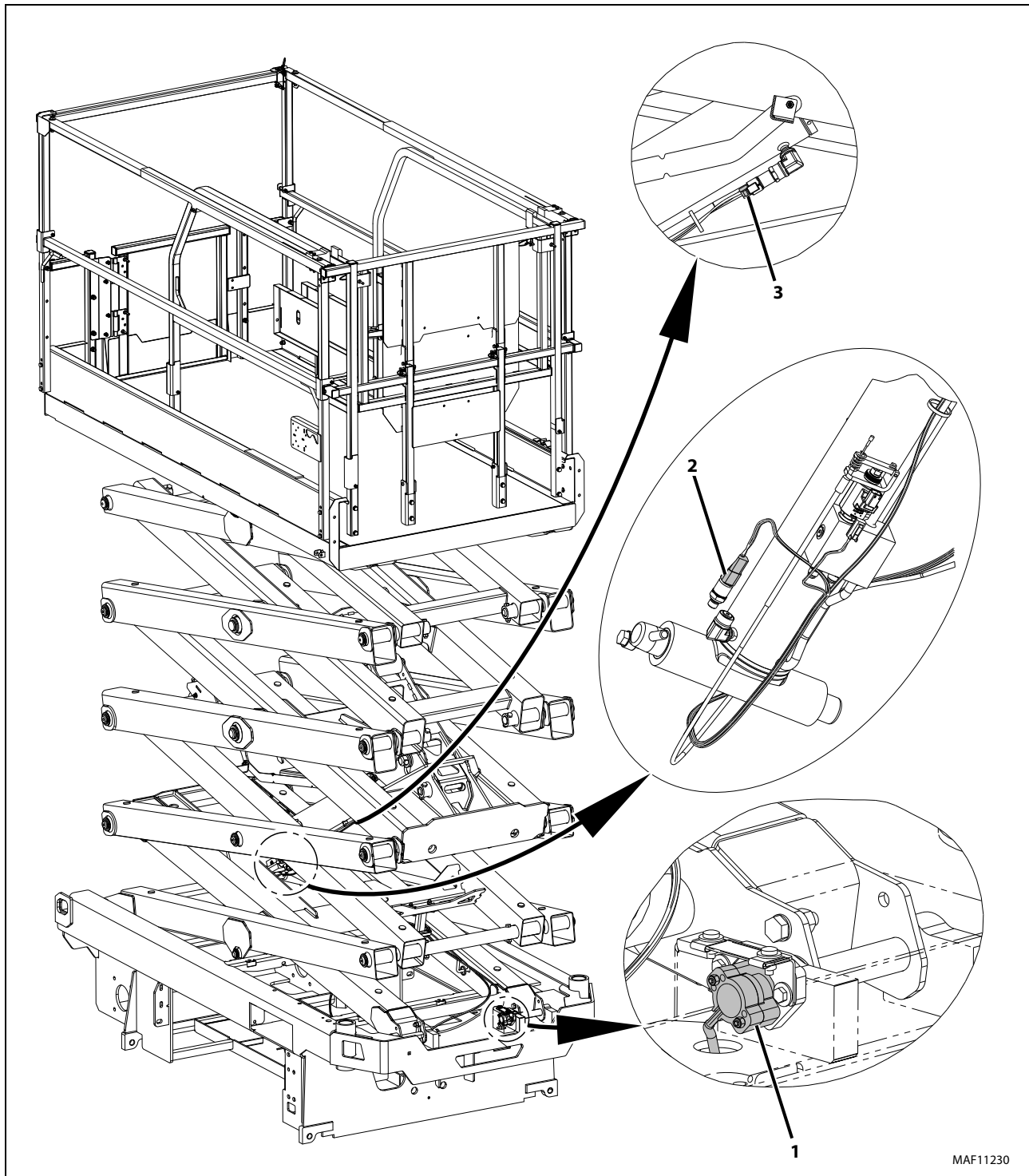

- 1. Arm Angle Sensor
- 2. Pressure Sensor (Barrel)

- 3. Pressure Sensor (Rod)

Figure 6-1. LSS Component Locations

6.2 ANALYZER INFORMATION

Personalities Menu

The following parameter in the PERSONALITIES, LOAD menu adjust performance of the LSS. All adjustments must be made in Access Level 1 (33271).

Table 6-1. Personalities Menu Description

SUBMENU (Displayed on Analyzer 1st line)	PARAMETER (Displayed on Analyzer 2nd Line)	DESCRIPTION
LOAD:	OVR DBNCE: 0.3 S	This parameter sets the debounce time (in seconds) where platform load must be greater than the capacity limit before triggering over-load
	OVR HOLD: 5.0 S	This parameter sets the minimum hold time (in seconds) where platform load must be less than the capacity limit before releasing over-load.
	ACC'Y: 0 KG	This parameter reduces the capacity limit for permanently mounted platform accessories.

Diagnostic Menu

The Diagnostic Load menu's are another troubleshooting tool for the Load Sensing System. Sensor and status information is presented in real-time for the technician.

To access the Diagnostic Menu, use the LEFT and RIGHT Arrow keys to select DIAGNOSTICS from the Top Level Menu. Press the ENTER key to select the menu.

NOTE: *The Diagnostic Load menu's are not available when the LSS is not enabled. (Machine Setup, Load is set to 0=Not Installed*

Press the LEFT and RIGHT arrow keys to view the load and angle sub-menu and press the enter key. Once in the load and angle submenu, press the LEFT and RIGHT arrow keys to view the various displays.

The Table 6-2 details the structure of the Diagnostic, Load Menu, and describes the meaning of each piece of information presented.

Table 6-2. Diagnostic Menu Descriptions

DIAGNOSTICS MENU (Displayed on Analyzer 1st Line)	PARAMETER (Displayed on Analyzer 2nd Line)	PARAMETER VALUE (Displayed on Analyzer 2nd Line)	DESCRIPTION
DIAGNOSTICS: LOAD			Menu available only when Machine Setup's LOAD is CUTOUT PLTM or CUTOUT ALL
	OVERLOADED? NO	NO/YES	Displays NO when the platform load is within rated capacity of the vehicle; YES when platform load is excessive
	PRES1 RAW: 0.00 mA/V	mA or Volts	Displays the lift cylinder head pressure 1 raw reading; shown as volts for R3246 and mA for all remaining models
	PRES1: XXXX PSI	0.0-9999.9 PSI	Displays the lift cylinder head pressure 1 scaled reading in PSI
	PRES1: XXXX.X BAR	0.0 to 9999.9 BAR	Displays the lift cylinder head pressure 1 scaled reading in BAR
	PRES2 RAW: 00.00 mA/V	mA or Volts	Displays the lift cylinder head pressure 2 raw reading; shown as volts for R3246 and mA for all remaining models
	PRES2: XXXX PSI	0.0-9999.9 PSI	Displays the lift cylinder head pressure 2 scaled reading in PSI
	PRES2: XXXX.X BAR	0.0 to 9999.9 BAR	Displays the lift cylinder head pressure 2 scaled reading in BAR
	PRES DIFF P1-P2: XXX PSI	0-999 PSI	Displays the difference between the lift cylinder 1 and 2 pressure readings
	PRES3 RAW: 0.00 V	0.00-9.99 V	Displays the lift cylinder rod pressure raw reading in volts
	PRES3: XXXX PSI	0.0-9999.9 PSI	Displays the lift cylinder rod pressure scaled reading in PSI
	PRES3: XXXX.X BAR	0.0 to 9999.9 BAR	Displays the lift cylinder rod pressure scaled reading in BAR
	NET FORCE: XX,XXX LBS	0.0 to 50,000 LBS	Displays the calculated lift cylinder net force in LBS
	PLT LOAD: XX,XXX LBS	0.0 to 25,000 LBS	Displays the estimate platform load in LBS
	110% CAL? NO	NO /YES	Displays NO when the vehicle is calibrated without test weights using CALIBRATIONS -> LOAD 0% only; YES when the vehicle is fully calibrated with test weights using CALIBRATIONS -> LOAD 0% and CALIBRATIONS -> LOAD 110%

6.3 CALIBRATION PREPARATION

The following procedure must be executed to prepare for calibration and verification.

NOTICE

IF THE CALIBRATION MUST BE PERFORMED OUTDOORS, ENSURE THE FOLLOWING ADDITIONAL CONDITIONS ARE MET BEFORE BEGINNING CALIBRATION PROCEDURES:

- **MACHINE IS ON A SLOPE LESS THAN OR EQUAL TO 0.5 DEGREE.**
 - **WIND SPEED IS LESS THAN OR EQUAL TO 20 MPH (32 KPH).**
 - **CALIBRATION WEIGHT IN THE PLATFORM IS CENTERED AND EVENLY DISTRIBUTED.**
1. Ensure the batteries are fully charged (24.5V or greater) and hydraulic fluid level is acceptable.
 2. Resolve any active control system faults before attempting calibration.

3. Park the vehicle on a level surface. The platform should be fully stowed and level within +/- 0.5 degrees in both directions.
4. Ensure the vehicle temperature is at least +32°F/0°C degrees Fahrenheit.
5. Complete Elevation Sensor calibration before attempting to calibrate the LSS.
6. Set key switch to Ground Mode.
7. Fully lift down to the stowed position.
8. Remove all foreign materials and debris from the platform.
9. Install any JLG Accessories that will be permanently attached (Electrician's Tree, Panel Carrier, etc.).
10. Connect the JLG Analyzer to the diagnostic port in the wire harness and enter the Access Level 1 password.
11. Adjust the PERSONALITY ' LOAD ' ACC'Y setting (See *Figure 6-1*) according to the documentation furnished with the factory-provided accessories or consult JLG.

Table 6-3. Calibrations Menu

MENU	SUBMENU	DESCRIPTION
CALIBRATIONS: LOAD 0%	CAL LOAD: YES:ENTER;NO:ESC	Press ENTER to begin calibration or ESC to exit
	CAL LOAD:FAIL NOT IN GND MODE	Vehicle must be calibrated in Ground Mode. Set the keyswitch to Ground Mode and retry.
	CAL LOAD:FAIL CAL ANGLE	Elevation sensor must be fully calibrated. Follow procedure at CALIBRATIONS -> SET STOW ELEV and CALIBRATIONS -> SET MAX ELEV and retry.
	CAL LOAD: PLATFORM EMPTY?	Verify the platform is empty and continue by pressing ENTER, or exit by pressing ESC.
	CAL LOAD:FAIL PLAT NOT STOWED	Vehicle must be fully stowed. Lift down and retry.
	CAL LOAD: LIFT TO MAX ELEV	Engage lift up so the control system can gather dynamic calibration information until the platform reaches maximum height and then press ENTER
	CAL LOAD: LOWER TO STOWED	Engage lift down so the control system can gather dynamic calibration information until the platform reaches the stowed position
	CAL LOAD: FAIL BATT < 24.5 V	On R3246, if system voltage is below 24.5 V at the beginning of 0% or 110% calibration procedures, voltage is allowed to drop below 24.5 V while calibrating and pump is running.
	CAL LOAD:FAIL MOTION STOPPED	Lift motion was interrupted and calibration could not be completed
	CAL LOAD: COMPLETE!	Load Sensing System calibration was successful
	CAL LOAD: CAL FAIL	Load Sensing System calibration was not successful so the original values were retained; retry

6.4 Calibration And Verification Procedure

Empty Platform Calibration

The following procedure should be executed to calibrate LSS with and without test weights.

1. Ensure the platform is empty.
2. Initiate calibration using the CALIBRATIONS ' LOAD 0% menu.
3. Lift up to maximum elevation using the ground controls when the LIFT TO MAX ELEV prompt appears.

NOTE: Lift up functions for R3246 will be slow for the first 4 ft (< 2 m) of travel.

4. Lift down to the stowed position using the ground controls when the LOWER TO STOWED prompt appears.
5. If successful, the Analyzer will display the COMPLETE prompt. If unsuccessful, a message will be displayed that will help lead to a resolution (reference the Troubleshooting section of this manual). Press ESC to return to the top level menu.

Loaded Platform Calibration

The following procedure should be executed to calibrate LSS with test weights.

1. Place weight corresponding to 110% of the vehicle's rated load in the center of the platform. See the chart below to determine the correct weight for calibration on each machine.

Table 6-4. Platform 110% Calibration Weight

MACHINE	CALIBRATION WEIGHT
	ANSI EXPORT CE GB CSA AUS
R3246	776 lb (352 Kg)
R2632	558 lb (253 Kg)

2. Initiate calibration using the CALIBRATIONS ' LOAD 110% menu.
3. Lift up to maximum elevation using the ground controls when the LIFT TO MAX ELEV prompt appears.
4. Lift down to the stowed position using the ground controls when the LOWER TO STOWED prompt appears.
5. If successful, the Analyzer will display the COMPLETE prompt. If unsuccessful, a message will be displayed that will help lead to a resolution (reference the Troubleshooting section of this manual). Press ESC to return to the top level menu.

LSS Verification

NOTE: Perform this verification procedure annually to confirm LSS is functioning properly.

The following procedure should be executed to verify LSS. Verification is a time-saving and effective diagnostic alternative to calibration at maintenance intervals. Refer to the troubleshooting section of this manual if the Load Sensing System fails to meet these guidelines.

1. Ensure the platform is empty.
2. Initiate verification using the CALIBRATIONS ' VERIFY menu.
3. Lift up to maximum elevation using the ground controls when the LIFT TO MAX ELEV prompt appears.
4. Lift down to the stowed position using the ground controls when the LOWER TO STOWED prompt appears.
5. If successful, the Analyzer will display the COMPLETE prompt. Press ESC to return to the top level menu.
6. If unsuccessful, the LSS - OUT OF CALIBRATION (8217) fault will be triggered and the LSS should be re-calibrated. Press ESC to return to the top level menu.

Partial Height Calibration

The machine can be calibrated to only reach a certain elevation when the machine is at maximum height.

To perform this calibration, ensure the platform is empty, the machine is parked on level ground, and the platform is in the stowed position.

1. Attach the Analyzer at the ground controls.
2. Go to Access Level 1, then scroll to the CALIBRATIONS LOAD 0% menu.
3. Lift up to desired maximum elevation using the ground controls when the LIFT TO MAX ELEV prompt appears.
4. Lift down to the stowed position using the ground controls when the LOWER TO STOWED prompt appears.
5. If successful, the Analyzer will display the COMPLETE prompt. If unsuccessful, a message will be displayed that will help lead to a resolution (refer to the Troubleshooting section of this manual). Press ESC to return to the top level menu.
6. Ensure the new maximum height has been set by running a lift up/lift down cycle.
7. Repeat steps 1 through 8 for Loaded Platform (Load 110%) calibration.

NOTE: To recalibrate the machine to reach full elevation, perform the Empty Platform (Load 0%) and Loaded Platform (Load 110%) Calibration. Allow the machine to reach full elevation.

6.5 TESTING

The following procedure should be executed to test LSS. The test confirms the LSS does not trigger when the platform carries 100% rated load, and the LSS continuously triggers when the platform carries 120% rated load. Refer to the troubleshooting section of this manual if the Load Sensing System fails to meet these guidelines.

1. Connect the JLG Analyzer to the diagnostic port in the wire harness and enter the Access Level 1 password.
2. Note the current setting of MACHINE SETUP ' LOAD and then adjust it to CUTOFF ALL. This will allow LSS interlocks to work from Ground Mode.
3. Place weight corresponding to 100% of the vehicle's rated load in the center of the platform. Refer to the LSS Testing Weight Table below.

Table 6-5. Platform 100% Calibration Weight

MACHINE	CALIBRATION WEIGHT
	ANSUSA ANSI EXPORT CE GB CSA JPN AUS KOR
R3246	Indoor
	705 lb (320 Kg)
R2632	Indoor
	507 lb (230 Kg)

4. Lift up to maximum elevation using the ground controls. LSS should not prevent motion and the Ground Overload Indicator should not illuminate.
5. Lift down to the stowed position using the ground control. LSS should not prevent motion and the Ground Overload Indicator should not illuminate.
6. Place weight corresponding to 120% of the vehicle's rated load in the center of the platform. Refer to the LSS Testing Weight Table above.

Table 6-6. Platform 120% Calibration Weight

MACHINE	CALIBRATION WEIGHT
R3246	Indoor
	846 lb (384Kg)
R2632	Indoor
	608 lb (276Kg)

7. Lift up using the ground controls. LSS should prevent motion after 1M of maximum platform height, the Ground Overload Indicator should flash, and the alarm should sound.
8. Use the JLG Analyzer to set MACHINE SETUP ' LOAD to CUTOFF PLTM. This will prevent LSS interlocks to work from Ground Mode.
9. Continue lift up using the ground controls. The Ground Overload Indicator should flash and the arm should sound. Pause at intervals to evaluate various heights. LSS indication should continue until the platform exceeds 90% of maximum platform height.
10. Lift down using the ground control. Pause at intervals to evaluate various heights. LSS indication should continue until the platform is nearly stowed.
11. If successful, the Analyzer will display the COMPLETE prompt. Press ESC to return to the top level menu and then re-adjust MACHINE SETUP ' LOAD to the original setting.
12. If unsuccessful, the LSS should be re-calibrated. Press ESC to return to the top level menu and then re-adjust MACHINE SETUP ' LOAD to the original setting.

6.6 LSS CONNECTOR PIN ASSIGNMENTS

(Also See Electrical Schematic - Section 8)

Connections for R3246 Lift Cylinder Rod Pressure Transducer

PIN	SIGNAL	DESCRIPTION
A	PWR	Pressure Transducer Supply (9-32 V)
B	SIG	20 - 4 mA (Voltage Feedback (0.5-4.5V))
C	GND	Pressure Transducer Ground (0V)

6.7 LSS TROUBLESHOOTING

The following tables are furnished to provide possible resolutions for common difficulties.

Table 6-7. LSS Troubleshooting

PROBLEM	POSSIBLE RESOLUTION
JLG Analyzer displays "FAIL NOT IN GND MODE" during LSS calibration	The technician has triggered the calibration process but the keyswitch is not in the Ground Mode position. Change the key-switch position and re-attempt LSS calibration.
JLG Analyzer displays "FAIL CAL ANGLE" during LSS calibration	The elevation sensor is not calibrated and this must be completed prior to LSS calibration. Execute the elevation sensor calibration procedure using CALIBRATIONS → SET STOW ELEV and CALIBRATIONS → SET MAX ELEV. Re-attempt LSS calibration afterward.
JLG Analyzer displays "FAIL PLAT NOT STOWED" during LSS calibration	The LSS calibration procedure must start with the platform completely stowed. Lift down using ground controls and then re-attempt LSS calibration.
JLG Analyzer displays "FAIL MOTION STOPPED" during LSS calibration	The technician released lift down during the LSS calibration procedure and the calibration data points could not be collected by the control system. Re-attempt LSS calibration.
JLG Analyzer displays "CAL FAIL" during LSS calibration	The technician halted the LSS calibration procedure by pressing ESC. Alternately, calibration data points collected from the vehicle did not fit within guidelines. This can be caused by debris in the platform, excessive slide block friction, or structural damage. This can also occur when accessories are fitted to the platform and the PERSONALITY → LOAD → ACC'Y setting is adjusted improperly. Remove debris and address any damaged components. Refer to the documentation for Sky Accessories.
LSS Visual and Audible Overload Warnings fail to sound when the platform is loaded beyond rated load. Controls remain functional at Ground and Platform Control positions.	<ul style="list-style-type: none"> LSS is not enabled in the control system. Connect the JLG Analyzer and enter the Access Level 1 password (33271). Navigate to MACHINE SETUP → LOAD and adjust the configuration to CUTOFF ALL to prevent platform and ground controls during an overload. Adjust the configuration to CUTOFF PLTM to prevent platform controls only during an overload. LSS requires re-calibration. Re-calibrate the elevation sensor first, and then the LSS using the procedures listed in this document.
LSS Visual and Audible Overload Warnings are active when the platform is empty.	<ul style="list-style-type: none"> LSS has not been calibrated or calibration has been lost. Calibration data points are stored within the Ground Module so replacement of this component will cause the need for re-calibration. Adjusting some settings within the MACHINE SETUP menu will also delete the calibration. LSS requires re-calibration. Re-calibrate the elevation sensor first, and then the LSS using the procedures listed in this document. A fault related to LSS has occurred and the vehicle has assumed the platform is overloaded to be conservative. Refer to the resolution of specific faults in the table below.
Controls remain functional at the Ground Control position during an overload. Controls at the Platform Control position are prevented.	The MACHINE SETUP → LOAD setting is configured to prevent Platform Controls only. Connect the JLG Analyzer and enter the Access Level 1 password (33271). Proceed to the MACHINE SETUP → LOAD menu and adjust the configuration to CUTOFF ALL to prevent platform and ground controls during an overload.
PLATFORM OVERLOADED (255) fault is triggered	This fault is triggered whenever the LSS is enabled and overloaded.
LSS HAS NOT BEEN CALIBRATED (825)	This fault is triggered when LSS has not been calibrated or a configuration change in MACHINE SETUP has deleted the calibration. Follow the procedure in this document for LSS calibration to resolve.
LSS – OUT OF CALIBRATION (8217)	LSS did not meet performance expectations during the verification procedure. If the procedure was not executed properly, cycle power and re-attempt. Otherwise, the LSS should be re-calibrated. Follow the procedure in this document for LSS calibration to resolve.
LIFT CYLINDER HEAD PRESSURE 1 – OUT OF RANGE HIGH (8523)	Pressure1RawValue is greater than 22.0mA for 500mS. Only applicable if {MACHINE SETUP-> LOAD = CUTOFF ALL or CUTOFF PLTM} AND {MACHINE SETUP --> LOAD CFG = PRESSURE}

SECTION 6 - LSS (LOAD SENSING SYSTEM) SERVICE

Table 6-7. LSS Troubleshooting (Continued)

LIFT CYLINDER HEAD PRESSURE 1 – OUT OF RANGE LOW (8524)	Pressure1RawValue is less than 3.5mA for 500mS. Only applicable if {MACHINE SETUP-> LOAD = CUTOFF ALL or CUTOFF PLTM}AND {MACHINE SETUP --> LOAD CFG = PRESSURE} and {MACHINE SETUP --> MODEL = 1532R, 1932R, 2632R, or 3247R}
LIFT CYLINDER HEAD PRESSURE 2 – OUT OF RANGE HIGH (8525)	For the R3246, this fault is triggered when the upper lift cylinder head pressure reading is high. This occurs when ground module V3-15 exceeds 4.75V for 500mS. Check the wire harness that connects to the lift cylinder for short circuits (crushed). Replace the lift cylinder head pressure transducer if the wire harness is intact. Refer to LSS Theory of Operation.
LIFT CYLINDER HEAD PRESSURE 2 – OUT OF RANGE LOW (8526)	For the R3246, this fault is triggered when the upper lift cylinder head pressure reading is low. This occurs when ground module V3-15 falls below 0.25V for 500mS. Check the wire harness that connects to the lift cylinder for open circuits (cut or crushed). Ensure the harness is connected to the pressure transducer and none of the contacts are out of position. Replace the lift cylinder head pressure transducer if the wire harness is intact. Refer to LSS Theory of Operation.
LIFT CYLINDER HEAD PRESSURE – DISAGREEMENT (8527)	For the R3246, this fault is triggered when the difference between the lower and upper lift cylinder head pressures is greater than 75PSI for 500mS during lift up (V4-7 & V3-15). The fault indicates an issue with the wire harness, pressure transducer(s), or the ground module. Confirm currents and voltages at the ground module to determine the origin of the issue. Refer to LSS Theory of Operation.
LIFT CYLINDER ROD PRESSURE 1 – OUT OF RANGE HIGH (8528)	This fault is triggered when the lift cylinder rod pressure reading is excessively high. This occurs when ground module V3-5 exceeds 4.75V for 500mS. Check the wire harness that connects to the lift cylinder for short circuits (crushed). Replace the lift cylinder rod pressure transducer if the wire harness is intact. Refer to LSS Theory of Operation.
LIFT CYLINDER ROD PRESSURE 1 – OUT OF RANGE LOW (8529)	This fault is triggered when the lift cylinder rod pressure reading is excessively low. This occurs when ground module V3-5 falls below 0.25V for 500mS. Check the wire harness that connects to the lift cylinder for open circuits (cut or crushed). Ensure the harness is connected to the pressure transducer and none of the contacts are out of position. Replace the lift cylinder rod pressure transducer if the wire harness is intact. Refer to LSS Theory of Operation.
LIFT CYLINDER ROD PRESSURE – DISAGREEMENT (8532)	This fault is triggered when the lift cylinder rod pressure fails to fall below 50PSI after 3000mS (V3-5). This fault is not detected when the vehicle is driving, lifting, or steering. This fault indicates an issue with the wire harness, pressure transducer, or the ground module. Confirm voltage at the ground module to determine the origin of the issue. Refer to LSS Theory of Operation.

SECTION 7. DIAGNOSTIC TROUBLE CODES

7.1 INTRODUCTION

This section provides a reference for Diagnostic Trouble Codes (DTC) read from the Multifunction Digital Indicator (MDI) or a handheld analyzer. For more information on any sensors or indicators, refer to the appropriate manual section. Many of the checks below require configuring and using a multimeter. Refer to Section 8: General Electrical Information & Schematics for multimeter basics. To troubleshoot multiple DTCs, start with the DTC with the higher first two digits. The machine is powered by four 6 Volt batteries in series, providing a nominal 24 Volts to the control system. Some procedures below refer to this nominal voltage (VMN) as 24V. Actual voltage measurements may differ based on the charge of the batteries. **If a correction is made during a check, conclude the check by cycling the machine power, using the emergency stop switch.** It may also be helpful to run a system test, ANALYZER -> SYSTEM TEST for intermittent or difficult problems.

System Fault/DTC Indication

In addition to the DTC codes being displayed on the MDI and handheld analyzer, DTC codes are indicated by the number of flashes and pauses of the System Fault indicator on the face of the platform control box as shown below:

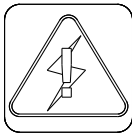

7.2 DIAGNOSTIC TROUBLE CODES (DTC)

The DTC tables following are sorted in groups by the first two digits, these digits represent the number of flashes the system distress indicator lamp will flash on the platform indicator panel when a fault occurs.

For example: a "211" on page 7-3 - Power Up would be indicated by 2 flashes, a pause, then 1 flash, a pause, then would keep repeating until the fault is cleared.

The more detailed three digit code numbers in the DTC column of the following tables are only indicated on a JLG handheld diagnostic analyzer.

To troubleshoot multiple DTCs, start with the DTC with the higher first two digits. **If a correction is made during a check, conclude the check by cycling the machine power off then back on, using the emergency stop switch.**

7.3 DTC CHECK TABLES

Table 7-1. Diagnostic Trouble Codes (DTC)

DTC	Help Message	Alarm	Flash Code	Action	Trigger	R3246/ R2632
001	EVERYTHING OK	None	None	• No Motion restrictions	Platform Mode and no Faults are active.	X
002	GROUND MODE OK	None	None	• No Motion restrictions	Ground Mode and no Faults are active.	X
003	ALARM SOUNDING – TILTED & ABOVE ELEVATION	PF: Continuous	None	• No Motion restrictions	Platform is elevated and chassis is not level • {MACHINE SETUP->TILT CUTOUT =NO} AND TransportState = FALSE AND TiltedState=TRUE	X
004	DRIVING AT CUTBACK – ABOVE ELEVATION	None	None	• Drive State = CREEP	Platform is elevated and the machine is in the drive mode of operation • In Platform Mode, TransportState=FALSE AND MoveState=DRIVE	X
005	DRIVE & LIFT UP PREVENTED TILTED & ELEVATED	PF: Continuous	None	• Drive State = PREVENTED • Lift Up State = PREVENTED	Driving and lift up are not possible since the platform is elevated and the chassis is not level. • In Platform Mode, TransportState=FALSE AND TiltedState=TRUE AND {MACHINE SETUP->TILT CUTOUT = YES}.	X
007	DRIVING AT CUTBACK – POT-HOLE STILL ENGAGED	None	None	• Drive State = CREEP	While stowed, drive speed is reduced (due to lower ground clearance) since the control system detected that the pot-hole protection mechanism is deployed (failed to retract). Clear the obstacle blocking the pot-hole protection mechanism, repair the mechanical problem, re-adjust the pot-hole limit switches, or repair the wiring to correct the problem. Alternately, there may be difficulty with the Elevation Angle Sensor that causes the Control System to improperly believe the platform is stowed. • Applicable only in Platform Mode, and Move State =DRIVE. • TransportState=TRUE AND the Pot-HoleState = BLOCKED or EXTENDED	X
008	FUNCTIONS LOCKED OUT – SYSTEM POWERED DOWN	None	None	• Enter Safe Mode • Lift Down State = PREVENTED	A period of time elapsed without activity and the Control System entered a low-power state to preserve battery charge and disarm controls. Cycle the Ground EMS in Ground Mode or the Platform EMS in Platform Mode to re-enable the vehicle. • 45 minutes without Drive Forward, Drive Reverse, Lift Up, Lift Down, Steer Left, or Steer Right in Platform Mode • 10 minutes without Lift Up or Lift Down in Ground Mode. • Timer resets if user changes Platform Mode/ Ground Mode	X
009	DRIVE PREVENTED – ELEVATED ABOVE DRIVE CUTOUT HEIGHT	None	None	• Drive State = PREVENTED	The Drive Cutout functionality is enabled, and the Platform is Elevated above the Calibrated Cutout Height. (Refer to Drive Cutout Functionality) • (Machine Setup-> Drive Cut-Out=YES) AND the Platform Height Value ≥ DriveCutValue	X

Table 7-1. Diagnostic Trouble Codes (DTC)

DTC	Help Message	Alarm	Flash Code	Action	Trigger	R3246/ R2632
0052	LIFT UP PREVENTED - MAX HEIGHT REACHED	None	None	• Lift Up State = PREVENTED	The vehicle has reached the maximum height allowed by the Indoor/Outdoor selection and further lift up motion is not possible. • PlatformHeightValue \geq MaxHeightAllowed-Value	X
0053	LIFT UP PREVENTED - LSS MAX HEIGHT	None	None	• Lift Up State = PREVENTED	The vehicle has reached the maximum height allowed by the LSS calibration and further lift up motion is not possible. • {MACHINE SETUP -> LOAD CFG=PRESSURE} • {MACHINE SETUP -> LOAD=CUTOPTLM or CUTOPTALL} • LSS was calibrated to partial height • PlatformHeightValue > LSS Partial Height Calibration Limit	X
211	POWER CYCLE	None	2_1	• No Motion restrictions	This Help Message is issued at each power-up. This serves to indicate which messages have been recorded in the failure log since the last power-up event.	X
212	KEYSWITCH FAULTY	None	2_1	• Force to Ground Mode	Both the Ground Select and Platform Select signals are energized, which means there is an issue with the keyswitch or one of the lines are shorted to battery. • V4-20 PF_SEL and V1-5 GRND_SEL are energized simultaneously.	X
221	FUNCTION PROBLEM – HORN PERMANENTLY SELECTED	None	2_2	• Horn Prevented	Horn Switch in the Platform Control Box was closed during power-up. Release or repair the switch to clear the message. • In Platform Mode and HORN is Energized during Platform Mode Startup. Retained until HORN is momentarily De-energized.	X
222	FUNCTION PROBLEM – INDOOR / OUTDOOR PERMANENTLY SELECTED	None	2_2	• Previously selected Indoor / Outdoor Mode maintained	Indoor / Outdoor Switch in the Platform Control Box was closed during power-up. Release or repair the switch to clear the message. • In Platform Mode, the IN/OUT switch is energized during Platform Mode Startup. Retained until IN/OUT is momentarily De-energized. • Only applicable if {MACHINE SETUP-> MARKET = CSA, CE, AUSTRALIA, or GB}	X
223	FUNCTION PROBLEM – DRIVE & LIFT ACTIVE TOGETHER	None	2_2	• Move State = LIFT • Drive State = PREVENTED • Lift Up State = PREVENTED • Lift Down State = MAX	The Drive - Lift Selector Switch indicates that both functions are selected simultaneously. Repair the wiring or switch to clear the message. • In Platform Mode and DRIVE_SEL and LIFT_SEL are energized at the same time. Retained until either is momentarily open circuit.	X

SECTION 7 - DIAGNOSTIC TROUBLE CODES

Table 7-1. Diagnostic Trouble Codes (DTC)

DTC	Help Message	Alarm	Flash Code	Action	Trigger	R3246/ R2632
224	FUNCTION PROBLEM – STEER LEFT PERMANENTLY SELECTED	None	2_2	• Drive State = PREVENTED	Steer Left Switch in the Platform Control Box was closed during power-up. Release or repair the switch to clear the message. • In Platform Mode, the STEER_L_SW is Energized during Platform Mode Startup. Retained until Digital Input is momentarily De-energized.	X
225	FUNCTION PROBLEM – STEER RIGHT PERMANENTLY SELECTED	None	2_2	• Drive State = PREVENTED	Steer Right Switch in the Platform Control Box was closed during power-up. Release or repair the switch to clear the message. • In Platform Mode, the STEER_R_SW is Energized during Platform Mode Startup. Retained until momentarily De-energized.	X
226	ACCELERATOR FAULTY – WIPER OUT OF RANGE	None	2_2	• Drive State = PREVENTED • Lift Up State = PREVENTED • Lift Down State = PREVENTED	The joystick (accelerator) wiper signal input is outside the acceptable voltage range. The wiper wire may be off, shorted to +B, or shorted to –B (ground) to cause this difficulty. • In Platform Mode, JOY_SIG is > 4.50V OR < 0.50V. Retained until the EMS is cycled.	X
227	STEER SWITCHES FAULTY	None	2_2	• Drive State = PREVENTED	Both the Steer Left and Steer Right Inputs are closed as the same time. A short in the Steer Switch wiring or a failed Steer Switch can cause this difficulty. • In Platform Mode, the STEER_L_SW is Energized AND STEER_R_SW is Energized. Retained until the EMS is cycled.	X
228	FUNCTION LOCKED OUT – ACCELERATOR NOT CENTERED	None	2_2	• Drive State = PREVENTED • Lift Up State = PREVENTED • Lift Down State = PREVENTED	Selected function (Drive or Lift) is not allowed because the joystick (accelerator) was not centered at power-up. Return joystick to center momentarily. • In Platform Mode, the JOY_SIG must be 0% and Stable (within +/- 0.05V change) for 1000mS after Power-up or this fault will be issued. Recovery permitted once the conditions are met (EMS re-cycle not necessary).	X
229	FUNCTION PROBLEM – TRIGGER PERMANENTLY CLOSED	None	2_2	• Drive State = PREVENTED • Lift Up State = PREVENTED • Lift Down State = PREVENTED	Trigger Switch in the Platform Control Box was closed at power-up. Release switch or repair the switch / wiring to clear the difficulty. • In Platform Mode, the TRIGGER is Energized during Platform Mode Startup. Cleared once TRIGGER is momentarily De-energized.	X
231	FUNCTION PROBLEM – LIFT PERMANENTLY SELECTED	None	2_3	In Ground Mode then • Lift Up State = PREVENTED • Lift Down State = PREVENTED	Lift Switch (Up or Down) in the Ground Control Box was closed during power-up. Release or repair the switch to clear the message. • In Ground Mode, [LIFT_UP_SW OR LIFT_D-N_SW is Energized] during Ground Mode Startup. Retained until the respective Digital Input is momentarily De-energized. • This fault should not become active in Platform Mode.	X

Table 7-1. Diagnostic Trouble Codes (DTC)

DTC	Help Message	Alarm	Flash Code	Action	Trigger	R3246/ R2632
232	GROUND LIFT UP/DOWN ACTIVE TOGETHER	None	2_3	In Ground Mode then <ul style="list-style-type: none"> Lift Up State = PREVENTED Lift Down State = PREVENTED 	In Ground Mode, the control system has detected the Lift Up and Down are active simultaneously. Check the Lift Switch and associated wiring in the Ground Control Box. <ul style="list-style-type: none"> In Ground Mode, LIFT_UP_SW is Energized AND LIFT_DN_SW is Energized. Retained until the EMS is cycled. This fault should not become active in Platform Mode. 	X
233	FUNCTION PROBLEM - BRAKE RELEASE PERMANENTLY SELECTED	None	2_3	In Ground Mode only <ul style="list-style-type: none"> Brake Release State = FALSE (Brake Release Option is not allowed to disengage brakes) 	In Ground Mode, the Manual Brake Release Digital Input is energized at power-up. Retained until the respective Digital Input is momentarily de-energized.	X
241	AMBIENT TEMPERATURE SENSOR – OUT OF RANGE LOW	PF: Continuous	2_4	• Drive and Lift Restrictions	The temperature as communicated by the temperature/tilt sensor is less than -40 degrees Celsius. <ul style="list-style-type: none"> If TransportState = FALSE, then set DriveState = CREEP, LiftDownState = CREEP LiftUpState = PREVENTED. The platform alarm shall continuously sound. If TransportState=TRUE, then set DriveState = MAX, LiftDownState = CREEP, and LiftUpState = PREVENTED, the platform alarm shall continuously sound. 	X
242	AMBIENT TEMPERATURE SENSOR – OUT OF RANGE HIGH	PF: Continuous	2_4	• Drive and Lift Restrictions	The temperature as communicated by the temperature/tilt sensor is greater than +85 degrees Celsius. <ul style="list-style-type: none"> If Transport State = FALSE, then set Drive State = CREEP, Lift Down State = MAX, and Lift Up State = PREVENTED. The platform alarm shall continuously sound. If TransportState=TRUE, then set Drive State = MAX, Lift Down State = MAX, and Lift Up State = PREVENTED, the platform alarm shall continuously sound. 	X
251	ELEV ANGLE SENSOR FAULTY – VOLTAGE OUT OF RANGE	None	2_5	<ul style="list-style-type: none"> Lift Up State = PREVENTED Platform Height Value assumed to be Full Elevation for the purposes of other interlocks Arm Guard Functionality shall be disabled Over Load State = TRUE if {MACHINE SETUP -> LOAD = CUTOUT PLTM or CUTOUT ALL} 	<p>The input voltage from the sensor that measures lower arm motion is outside acceptable range. This may be caused by difficulty with the sensor wiring, or a faulty sensor. Check mounting, review sensor wiring against the electrical schematic, or replace the sensor to clear the message.</p> <p>Fault should be triggered for any of the following conditions:</p> <ul style="list-style-type: none"> Elevation1RawValue > 4.5V or < 0.5V Elevation2RawValue > 4.5V or < 0.5V and {MACHINE SETUP -> LOAD = CUTOUT PLTM or CUTOUT ALL} 	X

SECTION 7 - DIAGNOSTIC TROUBLE CODES

Table 7-1. Diagnostic Trouble Codes (DTC)

DTC	Help Message	Alarm	Flash Code	Action	Trigger	R3246/ R2632
252	ELEV ANGLE SENSOR HAS NOT BEEN CALIBRATED	None	2_5	<ul style="list-style-type: none"> Lift Up State = PREVENTED Platform Height Value assumed to be Full Elevation for the purposes of other interlocks Over Load State = TRUE if {MACHINE SETUP->LOAD≠NO} 	<p>Calibrate the Elevation Angle Sensor using the calibration procedure to clear the message.</p> <ul style="list-style-type: none"> The Elevation Sensor's Calibration EEPROM is set to the signature implanted by the In-Circuit Test Fixture (has never been calibrated by the factory). Retained until Calibration EEPROM is over-written by a valid calibration. Need to recheck this setting for the redundant sensors as well if MACHINE SETUP->LOAD≠NO 	X
253	DRIVE PREVENTED – CHARGER CONNECTED	None	2_5	<ul style="list-style-type: none"> Drive State = PREVENTED 	<p>Driving is not possible since the vehicle is charging.</p> <ul style="list-style-type: none"> In Platform Mode, the ChargeInterlockState=TRUE AND MoveState = Drive. 	X
254	DRIVE & LIFT UP PREVENTED – CHARGER CONNECTED	None	2_5	<ul style="list-style-type: none"> Drive State = PREVENTED Lift Up State = PREVENTED 	<p>Driving and Lifting are not possible since the vehicle is charging and it is configured to prevent all motion.</p> <ul style="list-style-type: none"> ChargeInterlockState=TRUE AND {MACHINE SETUP-> CHARGE INTERLOC= DRV & LIFT UP}. 	X
255	PLATFORM OVERLOADED	<p>PF: 5000ms ON/2000ms OFF</p> <p>GND: 5000ms ON/2000ms OFF</p>	2_5	<ul style="list-style-type: none"> Drive State = PREVENTED if {MACHINE SETUP -> MARKET ≠ JAPAN} AND {TRANSPORT STATE = FALSE} Drive State = CREEP if {MACHINE SETUP -> MARKET = JAPAN} Lift Up State = PREVENTED if {(PlatformMode = TRUE) OR (Ground Mode = TRUE AND MACHINE SETUP -> LOAD = CUTOUT ALL)} 	<p>Triggers when Overload State = TRUE</p> <p>Clears when Overload State = FALSE</p> <p>While the Load Sensing System is enabled, the Platform Load measured by the Load Sensing System is excessive. Functions from Platform Control Station are prevented, and functions from Ground Control may be prevented, depending on machine configuration (Markets other than Japan). For the Japanese Market, only Lift Up is prevented and Drive (at creep speed) is allowed in the stowed position.</p> <p>Refer to LSS functionality for Lift and Drive restrictions.</p> <ul style="list-style-type: none"> This fault shall be suppressed if technician navigates to the CALIBRATIONS menu of the ANALYZER. 	X
256	DRIVE PREVENTED – POT-HOLE NOT ENGAGED	<p>If {MACHINE SETUP->PHP ALARM = YES}</p> <p>PF: 500ms On/ 500ms Off</p> <p>GND: 500ms On/500ms Off</p>	2_5	<ul style="list-style-type: none"> Drive State = PREVENTED 	<p>While elevated, driving is not possible since the control system detected that the pot-hole protection mechanism failed to deploy. Clear the obstacle blocking the pot-hole protection mechanism, repair the mechanical problem, re-adjust the pot-hole limit switches, or repair the wiring to correct the problem. Alternately, there may be difficulty with the Elevation Angle Sensor that causes the Control System to improperly believe the platform is elevated.</p> <ul style="list-style-type: none"> In Platform Mode AND Move State = DRIVE AND TransportState=FALSE AND AND PlatformHeightValue > PotholeNotEngagedValue AND PotholeState = BLOCKED or RETRACTED. Platform and Ground alarm shall only sound if {MACHINE SETUP->PHP ALARM = YES} and this DTC is active 	X

Table 7-1. Diagnostic Trouble Codes (DTC)

DTC	Help Message	Alarm	Flash Code	Action	Trigger	R3246/ R2632
258	DRIVE & LIFT PREVENTED - BRAKES ELECTRICALLY RELEASED FOR TOWING	Motion Alarm	2_5	<ul style="list-style-type: none"> • Drive State = PREVENTED • Lift Up State = PREVENTED • Lift Down State = PREVENTED 	<ul style="list-style-type: none"> • Brake Release Digital Input is Energized for 1000mS and Ground Mode is Selected. • Charger not charging • Brake Release Digital Input is not re-energized after initial activation 	X
259	MODEL CHANGED – HYDRAULICS SUSPENDED – CYCLE EMS	None	2_5	<ul style="list-style-type: none"> • Drive State = PREVENTED • Lift Up State = PREVENTED • Lift Down State = PREVENTED 	<p>The user changed the Model Selection using the JLG Analyzer. All functions are being prevented until the EMS is cycled.</p> <ul style="list-style-type: none"> • This fault shall be suppressed if DTC 9924 is active. Similar to DTC 9924 but a valid model has been selected • {MACHINE SETUP-> MODEL NUMBER} selection was changed via the Analyzer. 	X
311	OPEN CIRCUIT LINE CONTACTOR	None	3_1	<ul style="list-style-type: none"> • Drive State = PREVENTED • Lift Up State = PREVENTED 	<p>The vehicle's Main Line Contactor did not close when energized. Check the line contactor coil and the associated power wiring.</p> <ul style="list-style-type: none"> • The Power Module detected an open-circuit for the line contactor coil; alternately, the Negative Main Contactor driver was activated, but the line contactor did not provide voltage to the B+ terminal on the controller. • Power Module returns Main Line Contactor Open Fault <p><u>Curtis Code 39:Main Contactor Did Not Close</u> <u>Set:</u> With the main contactor commanded closed, the capacitor bank voltage (B+ connection terminal) did not charge to B+ <u>Effect:</u> Shutdown Motor, ShutdownMainContactor, ShutdownEMBrake, Shutdown Throttle, Full Brake, Shutdown Pump <u>Possible Cause:</u></p> <ul style="list-style-type: none"> • Main contactor did not close • Main contactor tips are oxidized, burned, or not making good contact. • External load on capacitor bank (B+ terminal connection) that prevents capacitor bank from charging. • Blown B+ fuse. 	X

SECTION 7 - DIAGNOSTIC TROUBLE CODES

Table 7-1. Diagnostic Trouble Codes (DTC)

DTC	Help Message	Alarm	Flash Code	Action	Trigger	R3246/ R2632
321	LINE CONTACTOR WELDED OR MISWIRED	None	3_2	<ul style="list-style-type: none"> • Drive State = PREVENTED • Lift Up State = PREVENTED 	<p>The Line contactor is off, but the Power Module is being energized. The line contactor's coil or power interconnect may be mis-wired. Alternately, the line contactor is faulty (welded or stuck).</p> <ul style="list-style-type: none"> • The Power Module did not activate the Negative Main Contactor driver, but battery voltage was detected on the B+ terminal of the controller. <p>Curtis Code 38: Main Contactor Welded Set: Just prior to the main contactor closing, the capacitor bank voltage (B+ connection terminal) was loaded for a short time and voltage did not discharge. Effect: Shutdown Motor, ShutdownMainContactor, ShutdownEMBrake, Shutdown Throttle, Full Brake, Shutdown Pump Possible Cause:</p> <ul style="list-style-type: none"> • Main contactor tips are welded closed. • Motor phase U or V is disconnected or open • An alternate voltage path (such as an external precharge resistor) is providing a current to the capacitor bank (B+ connection terminal) 	X
324	VALVE ENABLE DRIVER PERMANENTLY ON	None	3_2	<ul style="list-style-type: none"> • Drive State = PREVENTED • Lift Up State = PREVENTED 	<p>The VSW signal is shorted to Battery during startup prior to enabling the VSW switch.</p> <ul style="list-style-type: none"> • VSW > 14V when VSW switch is in the off state. 	X
331	BRAKE - SHORT TO BATTERY	None	3_3	<ul style="list-style-type: none"> • Disable Output • Drive State = PREVENTED • Lift Up State = PREVENTED 	<p>Short to Battery was detected on the GM_V5-5_Tow_Out digital output.</p>	X
332	BRAKE - OPEN CIRCUIT	None	3_3	<ul style="list-style-type: none"> • N/A 	<p>Open Circuit was detected on the GM_V5-5_Tow_Out digital output after attempting to activate Electronic Brake Release</p>	X
333	LIFT UP VALVE – SHORT TO BATTERY	None	3_3	<ul style="list-style-type: none"> • Disable Output • Lift Up State = PREVENTED • Drive State = PREVENTED 	<p>Short to Battery was detected on LIFT_UP_VLV</p>	X
334	LIFT UP VALVE – OPEN CIRCUIT	None	3_3	<ul style="list-style-type: none"> • Disable Output • Lift Up State = PREVENTED 	<p>Open Circuit detected on LIFT_UP_VLV</p>	X
335	LIFT DOWN VALVE – SHORT TO BATTERY	None	3_3	<ul style="list-style-type: none"> • Disable High side Output • Open Low side Output • Lift Down State = PREVENTED • Lift Up State = PREVENTED 	<p>Short to Battery was detected on LIFT_DN_VLV</p> <ul style="list-style-type: none"> • This fault covers both if the Highside Output or if the Lowside Output is shorted to Battery. 	X
336	LIFT DOWN VALVE – OPEN CIRCUIT	None	3_3	<ul style="list-style-type: none"> • Disable High side Output • Open Low side Output • Lift Down State = PREVENTED • Lift Up State = PREVENTED 	<p>Open Circuit detected on LIFT_DN_VLV</p>	X
337	STEER LEFT VALVE – SHORT TO BATTERY	None	3_3	<ul style="list-style-type: none"> • Disable Output • Drive State = PREVENTED • Lift Up State = PREVENTED 	<p>Short to Battery was detected on STEER_L_VLV</p>	X

Table 7-1. Diagnostic Trouble Codes (DTC)

DTC	Help Message	Alarm	Flash Code	Action	Trigger	R3246/ R2632
338	STEER LEFT VALVE – OPEN CIRCUIT	None	3_3	<ul style="list-style-type: none"> • Disable Output • Drive State = PREVENTED 	Open Circuit detected on STEER_L_VLV	X
339	STEER RIGHT VALVE – SHORT TO BATTERY	None	3_3	<ul style="list-style-type: none"> • Disable Output • Drive State = PREVENTED • Lift Up State = PREVENTED 	Short to Battery was detected on STEER_R_VLV	X
421	POWER MODULE TOO HOT - PLEASE WAIT	None	4_2	<ul style="list-style-type: none"> • Drive State = PREVENTED • Lift Up State = PREVENTED 	<p>Curtis Code 16: Controller Severe Overtemp Set: Heatsink temperature above 203°F (95°C). Effect: Shutdown Motor, ShutdownMainContactor, ShutdownEMBrake, Shutdown Throttle, Full Brake, Shutdown Pump Possible Cause:</p> <ul style="list-style-type: none"> • See Monitor menu>>Controller: Temperature • Controller is operating in an extreme environment. • Excessive load on vehicle. • Improper mounting of controller 	X
426	MASTER MODULE TEMPERATURE – OUT OF RANGE		4_2	<ul style="list-style-type: none"> • Normal operation 	<p>The Ground Module's internal temperature sensor is out of range. (< 104°F/40°C or > 302°F/150°C)</p> <ul style="list-style-type: none"> • Flag Error to show that analog input readings are not being temperature compensated, and allow normal operation. • Not having temperature compensation affects Elevation sensor accuracy and Pressure transducer accuracy 	X
441	BATTERY VOLTAGE TOO LOW – SYSTEM SHUTDOWN	None	4_4	<ul style="list-style-type: none"> • Enter Safe Mode • Lift Down State = MAX 	<p>Battery Voltage (VBAT) momentarily dropped below 14.5V when using flooded lead-acid batteries, or 16.0V when using AGM batteries. With a low battery charge, this can occur during heavy current demand due to Drive, Steer, or Lift Up. Recharge batteries or check for damaged batteries, sulfated batteries, or poor power connections.</p> <p>VBAT shall be measured at all times, and this fault can be engaged at any time, even while Driving, Lifting, or Steering is active.</p> <ul style="list-style-type: none"> • The Ground Module measured battery voltage less than 14.5V when {MACHINE SETUP-> BATTERY = FLOODED}. • The Ground Module measured battery voltage less than 16.0V when {MACHINE SETUP-> BATTERY = AGM}. • Suppress all Help Messages caused by the lack of system power. 	X

SECTION 7 - DIAGNOSTIC TROUBLE CODES

Table 7-1. Diagnostic Trouble Codes (DTC)

DTC	Help Message	Alarm	Flash Code	Action	Trigger	R3246/ R2632
442	BATTERY VOLTAGE TOO HIGH – SYSTEM SHUTDOWN	None	4_4	<ul style="list-style-type: none"> • Enter Safe Mode • Lift Down State = MAX 	<p>The Ground Module measured excessively high battery voltage (VBAT) (>32.0V) and de-energized the Main Line Contactor and Battery Relay to protect system devices and was unable to bring voltage down to normal operating range. This may be due to improper battery charging or incorrect voltage batteries being used.</p> <ul style="list-style-type: none"> • The Ground Module measured battery voltage greater than 32.0V for 10s while Charge-InterlockState = FALSE (see fault 4477) • Main Line Contactor and Battery Relay should be de-energized • Suppress all Help Messages caused by the lack of system power. 	X
443	LSS BATTERY VOLTAGE TOO HIGH	None	4_4	<ul style="list-style-type: none"> • Overload State= TRUE 	<p>While the Load Sensing System is enabled, the Load Sensing System Module measured Battery Voltage > 34.0Vdc, which may compromise ability to predict weight. This may be due to improper battery charging or incorrect voltage batteries being used.</p> <ul style="list-style-type: none"> • {MACHINE SETUP --> LOAD? NO} AND {MACHINE SETUP --> LOAD CFG = LOAD CELL} • LSS Module Message – Status Message (0x81) is reporting “BATT TOO HIGH” AND [Machine Setup’s LOAD is set to 1=CUTOUT PLT OR 2=CUTOUT ALL]. Refer to CANbus documentation for Load Sensing System Module. 	X
444	LSS BATTERY VOLTAGE TOO LOW	None	4_4	<ul style="list-style-type: none"> • Overload State= TRUE 	<p>While the Load Sensing System is enabled, the Load Sensing System Module measured Battery Voltage < 9.0Vdc, which may compromise ability to predict weight. With a low battery charge, this can occur during heavy current demand due to Drive, Steer, or Lift Up. Recharge batteries or check for damaged batteries.</p> <ul style="list-style-type: none"> • {MACHINE SETUP --> LOAD ≠ NO} AND {MACHINE SETUP --> LOAD CFG = LOAD CELL} • LSS Module Message – Status Message (0x81) is reporting “BATT TOO LOW” AND [Machine Setup’s LOAD is set to 1=CUTOUT PLT OR 2=CUTOUT ALL]. Refer to CANbus documentation for Load Sensing System Module. 	X
446	LOGIC SUPPLY VOLTAGE OUT OF RANGE LOW	None	4_4	<ul style="list-style-type: none"> • Drive State = PREVENTED • Lift Up State = PREVENTED 	<p>The Ground Module’s VSW voltage was measured to be out of range < 13V by the Ground Module. This may be caused by loose battery terminal, severely discharged batteries, a damaged battery, or an improper wire harness connection.</p> <ul style="list-style-type: none"> • This fault shall be suppressed if DTC 441 is active. 	X

Table 7-1. Diagnostic Trouble Codes (DTC)

DTC	Help Message	Alarm	Flash Code	Action	Trigger	R3246/ R2632
447	VOLTAGE REFERENCE OUT OF RANGE	None	4_4	<ul style="list-style-type: none"> Lift Up State = PREVENTED Platform Height Value assumed to be Full Elevation for the purposes of other interlocks OverLoad State = TRUE 	The Ground Modules 5V supply voltage was measured to be out of range (<4.5V or >5.5V). This may be caused by loose battery terminal, severely discharged batteries, a damaged battery, or an improper wire harness connection.	X
448	VOLTAGE REFERENCE OUT OF RANGE	None	4_4	<ul style="list-style-type: none"> Lift Up State = PREVENTED Drive State = PREVENTED 	The Ground Modules 3.3V supply voltage was measured to be out of range (<3.135V or >3.465V). This may be caused by issues with the 3.3V supply or the V5P0 reference supply on the Ground Module.	X
661	CANBUS FAILURE – POWER MODULE	None	6_6	<ul style="list-style-type: none"> Drive State = PREVENTED Lift Up State = PREVENTED 	<p>The control system failed to receive messages from the Pump Module. This may occur if re-programming was interrupted. Alternately, this may be an internal fault.</p> <ul style="list-style-type: none"> Pump Module Messages not received for 250mS This error shall be suppressed anytime that VSW is De-energized or if unit is in SafeMode <p>Curtis Code 51: Communication Fault Set:Ground Module is unable to communicate with Pump Module. Effect: ShutdownMotor,ShutdownMainContactor,ShutdownEMBrake, Shutdown Throttle, Full Brake, Shutdown Pump Possible Cause:</p> <ul style="list-style-type: none"> CAN speed or protocol mismatch CAN wires damaged. Controller is disconnected. 	X
662	CANBUS FAILURE – PLATFORM MODULE	None	6_6	<ul style="list-style-type: none"> All Platform functions Prevented. Normal operation from Ground Mode 	<p>In PlatformMode, the control system failed to receive messages from the Platform Module. Check wiring at the Platform Box. Check wiring along scissor arms leading up to Platform.</p> <ul style="list-style-type: none"> Digital Input Message – Motion (0x00) not received for 250mS AND Platform Mode selected. This error shall be suppressed anytime that VSW is De-energized or if unit is in Safe Mode 	X
663	CANBUS FAILURE - LOAD SENSING SYSTEM MODULE	None	6_6	<ul style="list-style-type: none"> Overload State= TRUE 	<ul style="list-style-type: none"> With the Load Sensing System enabled AND [Machine Setup's LOAD CFG is set to LOAD CELL], the control system failed to receive messages from the Load Sensing System Module. 	X

SECTION 7 - DIAGNOSTIC TROUBLE CODES

Table 7-1. Diagnostic Trouble Codes (DTC)

DTC	Help Message	Alarm	Flash Code	Action	Trigger	R3246/ R2632
811	TILT SENSOR NOT CALIBRATED	None	8_1	<ul style="list-style-type: none"> Tilted State =TRUE (+20.0° X, +20.0° Y); Max Drive Speed Value = Worst-Case Slope Descent Functionality for both Forward and Reverse 	<p>The Chassis Tilt Sensor has never been calibrated so the control system assumes that the vehicle is tilted. Drive speed is reduced since a valid tilt reading is not available. Calibrate the Tilt Sensor using the calibration procedure to clear the message.</p> <ul style="list-style-type: none"> The Tilt Sensor's Calibration EEPROM is set to the signature implanted by the In-Circuit Test Fixture. Retained until Calibration EEPROM is over-written by a valid calibration. 	X
821	LSS CELL #1 ERROR	None	8_2	<ul style="list-style-type: none"> Overload State= TRUE 	<ul style="list-style-type: none"> LSS Module Message – Status Message (0x81) is reporting “CELL 1 ERROR” AND [Machine Setup's LOAD is set to 1=CUTOUT PLT OR 2=CUTOUT ALL] AND [Machine Setup's LOAD CFG is set to LOAD CELL]. Refer to CAN-bus documentation for Load Sensing System Module. 	X
822	LSS CELL #2 ERROR	None	8_2	<ul style="list-style-type: none"> Overload State= TRUE 	<ul style="list-style-type: none"> LSS Module Message – Status Message (0x81) is reporting “CELL 2 ERROR” AND [Machine Setup's LOAD is set to 1=CUTOUT PLT OR 2=CUTOUT ALL] AND [Machine Setup's LOAD CFG is set to LOAD CELL]. Refer to CAN-bus documentation for Load Sensing System Module. 	X
823	LSS CELL #3 ERROR	None	8_2	<ul style="list-style-type: none"> Overload State= TRUE 	<ul style="list-style-type: none"> LSS Module Message – Status Message (0x81) is reporting “CELL 3 ERROR” AND [Machine Setup's LOAD is set to 1=CUTOUT PLT OR 2=CUTOUT ALL] AND [Machine Setup's LOAD CFG is set to LOAD CELL]. Refer to CAN-bus documentation for Load Sensing System Module. 	X
824	LSS CELL #4 ERROR	None	8_2	<ul style="list-style-type: none"> Overload State= TRUE 	<ul style="list-style-type: none"> LSS Module Message – Status Message (0x81) is reporting “CELL 4 ERROR” AND [Machine Setup's LOAD is set to 1=CUTOUT PLT OR 2=CUTOUT ALL] AND [Machine Setup's LOAD CFG is set to LOAD CELL]. Refer to CAN-bus documentation for Load Sensing System Module. 	X

Table 7-1. Diagnostic Trouble Codes (DTC)

DTC	Help Message	Alarm	Flash Code	Action	Trigger	R3246/ R2632
825	LSS HAS NOT BEEN CALIBRATED	None	8_2	• Overload State= TRUE	Only applicable when MACHINE SETUP --> LOAD is CUTOUT PLTM or CUTOUT ALL. The Load Sensing System has never been calibrated, previous vehicle model LSS calibration does not match current model, or previous LSS calibration version is different from current version. Follow the calibration procedure to clear the message.	X
991	LSS WATCHDOG RESET	None	9_9	No Motion Interlocks	The Watchdog Timer on Load Sensing System Module's microprocessor was triggered by exposure to excessive electrical noise, or by a hardware difficulty. Re-cycle power to clear difficulty. <ul style="list-style-type: none"> • {MACHINE SETUP --> LOAD ≠ NO} AND {MACHINE SETUP --> LOAD CFG = LOAD CELL} • LSS Module Message – Status Message (0x81) is reporting "WATCHDOG RST" AND [Machine Setup's LOAD is set to 1=CUTOUT PLT OR 2=CUTOUT ALL]. Refer to CANbus documentation for Load Sensing System Module. Retained until power is re-cycled 	X
992	LSS EEPROM ERROR	None	9_9	• Overload State= TRUE	Memory used to retain settings on Load Sensing System Module has been corrupted. Re-calibrate and verify the Load Sensing System. Alternately, this may indicate an LSS Module malfunction. <ul style="list-style-type: none"> • {MACHINE SETUP --> LOAD ≠ NO} AND {MACHINE SETUP --> LOAD CFG = LOAD CELL} • LSS Module Message – Status Message (0x81) is reporting "EEPROM ERROR" AND [Machine Setup's LOAD is set to 1=CUTOUT PLT OR 2=CUTOUT ALL]. Refer to CANbus documentation for Load Sensing System Module. Retained until power is re-cycled 	X
993	LSS INTERNAL ERROR – PIN EXCITATION	None	9_9	• Overload State= TRUE	The Excitation Voltage for the Load Sensors < 4.25V. The sensors may be excessively loading the Excitation Supply due to wiring damage, or the Load Sensing System Module may have hardware difficulty. <ul style="list-style-type: none"> • {MACHINE SETUP --> LOAD ≠ NO} AND {MACHINE SETUP --> LOAD CFG = LOAD CELL} • LSS Module Message – Status Message (0x81) is reporting "INTERNAL ERROR – PIN EXCITATION < 4.25V" AND [Machine Setup's LOAD is set to 1=CUTOUT PLT OR 2=CUTOUT ALL]. Refer to CANbus documentation for Load Sensing System Module. Retained until power is re-cycled 	X

Table 7-1. Diagnostic Trouble Codes (DTC)

DTC	Help Message	Alarm	Flash Code	Action	Trigger	R3246/ R2632
994	LSS INTERNAL ERROR – DRDY MISSING FROM A/D	Latched	Latched	• Overload State= TRUE	The DRDY Interrupt from the Load Sensing System Module's A/D Converter is missing. This may indicate Load Sensing System Module hardware difficulty. <ul style="list-style-type: none"> • {MACHINE SETUP --> LOAD ≠ NO} AND {MACHINE SETUP --> LOAD CFG = LOAD CELL} • LSS Module Message – Status Message (0x81) is reporting "INTERNAL ERROR – DRDY INTERRUPT FROM A/D" AND [Machine Setup's LOAD is set to 1=CUTOUT PLT OR 2=CUTOUT ALL]. Refer to CANbus documentation for Load Sensing System Module. Retained until power is re-cycled 	X
995	POWER MODULE FAILURE - PERSONALITY RANGE ERROR	None	9_9	• Drive State = PREVENTED • Lift Up State = PREVENTED	The Pump Module detected an out-of-range or corrupt personality setting. Reset control system Personalities to default settings to clear difficulty. Curtis Code 82: Bad Calibrations Set: Calibration values are missing or out of range. Effect: Shutdown Motor, Shutdown Main Contactor, Shutdown EM Brake, Shutdown Throttle, Full Brake, Shutdown Pump Possible Cause: <ul style="list-style-type: none"> • Memory issues • Incorrect settings 	X
997	POWER MODULE FAILURE - CHECK POWER CIRCUITS OR MOSFET SHORT CIRCUIT	None	9_9	• Drive State = PREVENTED • Lift Up State = PREVENTED	Curtis Code 95: Pump Overcurrent Fault Set: Pump current exceeded the current measurement limit. Effect: Shutdown Pump Possible Cause: <ul style="list-style-type: none"> • External short of the pump motor • Controller defective 	X
998	EEPROM FAILURE – CHECK ALL SETTINGS	None	9_9	• Enter Safe Mode • Lift Down State = PREVENTED	The control system detected an EEPROM failure. Personalities and Machine Setup settings may be reset to default values. Check / correct all settings and re-cycle power to clear difficulty. <ul style="list-style-type: none"> • The Ground Module's EEPROM checksum indicates corruption. Retained until EEPROM settings are corrected and power is re-cycled. 	X

Table 7-1. Diagnostic Trouble Codes (DTC)

DTC	Help Message	Alarm	Flash Code	Action	Trigger	R3246/ R2632
999	FUNCTIONS LOCKED OUT - POWER MODULE SOFTWARE VERSION IMPROPER	None	9_9	<ul style="list-style-type: none"> • Drive State = PREVENTED • Lift Up State = PREVENTED 	<p>The control system will not function because the Pump Module Software Version is not compatible with the rest of the system. Re-program or replace with the version matched to the Ground Module</p> <ul style="list-style-type: none"> • The Pump Module reported a Software Type, Software Major, or Software Minor Version that was not equal to Interface Module (all must match for compatibility). The control system may resume operation once the difficulty has been corrected. <p>Curtis Code 98: Illegal Model Number Set: Illegal Mecklenburg variable; when KSI cycles, a check is made to confirm a legal Model_Number, and a fault is issued if one is not found.</p> <p>Effect: ShutdownMotor, ShutdownMainContactor, ShutdownEMBrake, Shutdown Throttle, Full Brake, Shutdown Pump</p> <p>Possible Cause:</p> <ul style="list-style-type: none"> • Model_Number variable contains illegal value (not 1210). • Software and Hardware do not match • Controller defective. 	X
2210	TRIGGER CLOSED TOO LONG WHILE IN NEUTRAL	None	2_2	<ul style="list-style-type: none"> • Trigger State = FALSE therefore • Drive State = PREVENTED • Lift Up State = PREVENTED • Lift Down State = PREVENTED 	<p>Trigger Switch in the Platform Control Box was closed for more than five seconds while the Joystick (accelerator) was in the neutral position (centered). Release switch or repair the switch / wiring to clear the difficulty.</p> <ul style="list-style-type: none"> • In Platform Mode, the TRIGGER input was Energized for 5,000mS AND JoystickCommand is 0% and Stable (within +/- 0.05V change). Retained until the TRIGGER input is momentarily De-energized. 	X
2232	FUNCTION PROBLEM – DRIVE & LIFT BOTH OPEN	None	2_2	<ul style="list-style-type: none"> • Move State = LIFT • Drive State = PREVENTED • Lift Up State = PREVENTED • Lift Down State = MAX 	<p>In Platform Mode, the Drive - Lift Selector Switch indicates that neither function is selected. Repair the wiring or switch to clear the message.</p> <ul style="list-style-type: none"> • In Platform Mode, the DRIVE_SEL and LIFT_SEL are open circuit at the same time. Retained until either is momentarily energized. 	X

Table 7-1. Diagnostic Trouble Codes (DTC)

DTC	Help Message	Alarm	Flash Code	Action	Trigger	R3246/R2632
2512	ELEV ANGLE SENSOR NOT DETECTING CHANGE	None	2_5	<ul style="list-style-type: none"> Lift Up State = PREVENTED Platform Height Value assumed to be Full Elevation 	<p>When {MACHINE SETUP --> MODEL is not 4045R} The input voltage from the Elevation Angle Sensor that measures lower arm motion did not respond properly while the vehicle is lifting up. Check mounting, review sensor wiring against the electrical schematic, or replace the sensor to clear the message. This fault is not required for the redundant elevation angle sensor fitted for pressure-based LSS systems.</p> <ul style="list-style-type: none"> Elevation1RawValue does not change more than 0.3 degrees of elevation for 5000mS or decreases while lifting up PlatformHeightValue < (PhysicalMinHeightValue + 95% PlatformHeightRange) PumpCommand > {PERSONALITY -> LIFT -> UP MIN} + 40% ({PERSONALITY -> LIFT -> UP MAX} - {PERSONALITY -> LIFT -> UP MIN}) DTC251 ELEV ANGLE SENSOR FAULTY – VOLTAGE OUT OF RANGE not active DTC252 ELEV ANGLE SENSOR HAS NOT BEEN CALIBRATED not active MACHINE SETUP --> LOAD = NONE 	X
2512	ELEV ANGLE SENSOR NOT DETECTING CHANGE	None	2_5	<ul style="list-style-type: none"> Lift Up State = PREVENTED Platform Height Value assumed to be Full Elevation 	<p>When {MACHINE SETUP --> MODEL = 4045R} The input voltage from the Elevation Angle Sensor that measures lower arm motion did not respond properly while the vehicle is lifting up. Check mounting, review sensor wiring against the electrical schematic, or replace the sensor to clear the message. This fault is not required for the redundant elevation angle sensor fitted for pressure-based LSS systems.</p> <ul style="list-style-type: none"> Elevation1RawValue does not change more than 0.3 degrees of elevation for 7000mS or decreases while lifting up PlatformHeightValue < (PhysicalMinHeightValue + 95% PlatformHeightRange) PumpCommand > {PERSONALITY -> LIFT -> UP MIN} + 40% ({PERSONALITY -> LIFT -> UP MAX} - {PERSONALITY -> LIFT -> UP MIN}) DTC251 ELEV ANGLE SENSOR FAULTY – VOLTAGE OUT OF RANGE not active DTC252 ELEV ANGLE SENSOR HAS NOT BEEN CALIBRATED not active MACHINE SETUP --> LOAD = NONE 	X

Table 7-1. Diagnostic Trouble Codes (DTC)

DTC	Help Message	Alarm	Flash Code	Action	Trigger	R3246/ R2632
2516	DRIVE PREVENTED - ABOVE ELEVATION	None	2_5	<ul style="list-style-type: none"> • Drive State = PREVENTED 	In Platform Mode, function select is set to Drive and LowHeightDriveCutState is TRUE.	X
2520	FUNCTIONS LOCKED OUT - CONSTANT DATA VERSION IMPROPER	None	2_5	<ul style="list-style-type: none"> • Drive State = PREVENTED • Lift Up State = PREVENTED • Lift Down State = PREVENTED 	<p>The Ground Module's Application and Constant-Data Versions do not match which could lead to improper operation therefore machine shall not be allowed to function.</p> <ul style="list-style-type: none"> • The Ground Module's Application and Constant Data Versions do not match 	X
2568	TEMPERATURE CUTOUT ACTIVE - AMBIENT TEMPERATURE TOO LOW	<p>If Transport Mode = TRUE PF: Continuous</p> <p>If Transport Mode = FALSE PF: OFF</p>	2_5	<ul style="list-style-type: none"> • Drive and Lift Restrictions 	<p>The temperature as communicated by the temperature sensor located on the temperature/tilt sensor is less than or equal to {PERSONALITIES->TEMP CUTOUT->CUTOUT SET} (See Low Temperature Cutout Functionality)</p> <ul style="list-style-type: none"> • Only applicable if {MACHINE SETUP->LOW TEMP CUTOUT=YES} • This DTC shall not be displayed in Ground Mode, and no restrictions shall be implemented. 	X
2586	FUNCTIONS PREVENTED - OVERHEAD OBSTRUCTION	None	2_5	<ul style="list-style-type: none"> • Lift Up State = PREVENTED • If Transport State is FALSE, Drive State = PREVENTED 	<ul style="list-style-type: none"> • MACHINE SETUP --> OVERHEAD PROTECT = YES • Overhead protection switch is open • The machine is in Platform Mode OR (The machine is in Ground Mode AND the platform box is detected on CAN. 	X
3213	POWER MODULE MAIN CONTACTOR - SHORT TO GROUND OR OPEN CIRCUIT	None	3_2	<ul style="list-style-type: none"> • Drive State = PREVENTED • Lift Up State = PREVENTED 	<p>Curtis Code 31: Coil 1 Driver Open/Short Set: Driver 1 (pin 6) is either open or shorted. This fault can be set only when Main Enable = Off Effect: ShutdownDriver1 Possible Cause:</p> <ul style="list-style-type: none"> • Open or short on driver load. • Dirty connector pins. • Bad crimps or faulty wiring. <p>Curtis Code 31: Main Open/Short Set: Main Contactor Driver (pin 6) is either open or shorted. This fault can be set only when Main Enable = On Effect: Shutdown Motor, ShutdownMainContactor, ShutdownEMBrake, Shutdown Throttle, Full Brake, Shutdown Pump Possible Cause:</p> <ul style="list-style-type: none"> • Open or short on driver load. • Dirty connector pins. • Bad crimps or faulty wiring. 	X
3310	STEER RIGHT VALVE – OPEN CIRCUIT	None	3_3	<ul style="list-style-type: none"> • Disable Output • Drive State = PREVENTED 	Open Circuit detected on STEER_R_VLV	X

SECTION 7 - DIAGNOSTIC TROUBLE CODES

Table 7-1. Diagnostic Trouble Codes (DTC)

DTC	Help Message	Alarm	Flash Code	Action	Trigger	R3246/ R2632
3311	GROUND ALARM– SHORT TO BATTERY	None	3_3	• Disable Output	Only applicable if {MACHINE SETUP->WHITE NOISE ALARM=YES} Short to Battery was detected on WN_ALARM	X
3361	BRAKE - SHORT TO GROUND	None	3_3	• Brake Release State = FALSE (Brake Release Option is not allowed to disengage brakes) • Disable output	Short to Ground was detected on the GM_V5-5_Tow_Out digital output. This DTC shall only be reported if the BrakeReleaseState was set to TRUE	X
3368	TWO SPEED VALVE - SHORT TO GROUND	None	3_3	Platform Mode • Disable output, Normal Operation	Short to Ground was detected on 2SPD_VLV AND {MACHINE SETUP-> MODEL =4045R or 3246R}. Ignore this Fault in GroundMode	X
3369	TWO SPEED VALVE - OPEN CIRCUIT	None	3_3	Platform Mode • Normal Operation	Open Circuit detected on 2SPD_VLV AND {MACHINE SETUP-> MODEL =4045R or 3246R}. Ignore this Fault in GroundMode	X
3370	TWO SPEED VALVE - SHORT TO BATTERY	None	3_3	Platform Mode • Disable output • Lift Up State = PREVENTED and Transport = False • Drive State = PREVENTED	Short to Battery was detected on 2SPD_VLV AND {MACHINE SETUP-> MODEL =4045R or 3246R}. Ignore this Fault in GroundMode	X
3371	GROUND ALARM– SHORT TO GROUND	None	3_3	• Disable output	Short to Ground was detected on WN_ALARM Only applicable if {MACHINE SETUP->WHITE NOISE ALARM=YES}	X
3379	HOUR METER– SHORT TO GROUND	None	3_3	• Disable output	Short to Ground was detected on HOUR_MTR	X
3380	HOUR METER– OPEN CIRCUIT	None	3_3	• Disable output	Open Circuit was detected on HOUR_MTR	X
3381	HOUR METER– SHORT TO BATTERY	None	3_3	• Disable output	Short to Battery was detected on HOUR_MTR	X
4235	POWER MODULE TOO HOT - REDUCED OPERATION	None	4_2	• Drive State = CREEP • Lift Up State = CREEP	Curtis Code 22: Controller Overtemp Cut-back Set: Heatsink temperature exceeded 185°F (85°C). Effect: Reduced drive and brake torque. Possible Cause: • See Monitor menu>>Controller: Temperature • Controller is performance-limited at this temperature. • Controller is operating in an extreme environment. • Excessive load on vehicle • Improper mounting of controller.	X
4236	POWER MODULE TOO COLD - MODULE SHUTDOWN	None	4_2	• Drive State = PREVENTED • Lift Up State = PREVENTED	Curtis Code 15: Controller Severe Under-temp Set: Heatsink temperature below -40°F (-40°C). Effect: ShutdownMotor,ShutdownMainContactor,ShutdownEMBrake, ShutdownThrottle, Full-Brake, ShutdownPump Possible Cause: • See Monitor menu>>Controller: Temperature • Controller is operating in an extreme environment.	X

Table 7-1. Diagnostic Trouble Codes (DTC)

DTC	Help Message	Alarm	Flash Code	Action	Trigger	R3246/ R2632
4421	LOGIC SUPPLY VOLTAGE OUT OF RANGE HIGH	None	4_4	<ul style="list-style-type: none"> • Enter Safe Mode • Lift Down State = MAX 	The Ground Module's VSW voltage was measured to be more than 32V. This may be caused by loose battery terminal, severely discharge batteries, a damaged battery, or an improper wire harness connection.	X
4424	POWER MODULE VOLTAGE TOO LOW - MODULE SHUTDOWN	None	4_4	<ul style="list-style-type: none"> • Drive State = PREVENTED • Lift Up State = PREVENTED 	<p>Curtis Code 17: Severe B+ Undervoltage Set: Capacitor bank voltage dropped below Severe Undervoltage limit with FET bridge enabled. Effect: Reduced Drive Torque Possible Cause:</p> <ul style="list-style-type: none"> • Battery menu parameters are misadjusted • Non-controller system drain on battery • Battery resistance too high • Battery disconnected while driving • See Monitor menu>>Battery: Capacitor Voltage • Blown B+ fuse or main contactor not closed 	X
4425	POWER MODULE VOLTAGE TOO HIGH - MODULE SHUTDOWN	None	4_4	<ul style="list-style-type: none"> • Drive State = PREVENTED • Lift Up State = PREVENTED 	<p>Curtis Code 18: Severe B+ Overvoltage Set: Capacitor bank voltage exceeded the Severe Overvoltage limit with FET bridge enabled Effect: ShutdownMotor, ShutdownMainContactor, ShutdownEMBrake, ShutdownThrottle, Full-Brake, ShutdownPump Possible Cause:</p> <ul style="list-style-type: none"> • See Monitor menu>>Battery: Capacitor Voltage • Battery menu parameters are misadjusted • Battery resistance too high for given regen current. • Battery disconnected while regen braking. 	X
4473	POWER MODULE VOLTAGE TOO LOW - REDUCED OPERATION	None	4_4	<ul style="list-style-type: none"> • Drive State = CREEP • Lift Up State = CREEP 	<p>Curtis Code 23: B+ Undervoltage Cutback Set: Capacitor bank voltage dropped below the Undervoltage limit with FET bridge enabled Effect: Reduced Drive Torque Possible Cause:</p> <ul style="list-style-type: none"> • Normal operation. Fault shows that the batteries need recharging. Controller performance limited at this voltage. • Battery menu parameters are mis-adjusted • Non-controller system drain on battery • Battery resistance too high. • Battery disconnected while driving • See Monitor menu>>Battery: Capacitor Voltage • Blown B+ fuse or main contactor did not close 	X

Table 7-1. Diagnostic Trouble Codes (DTC)

DTC	Help Message	Alarm	Flash Code	Action	Trigger	R3246/ R2632
4474	POWER MODULE VOLTAGE TOO HIGH - REDUCED OPERATION	None	4_4	<ul style="list-style-type: none"> • Drive State = CREEP • Lift Up State = CREEP 	<p>Curtis Code 24: B+ Overvoltage Cutback Set: Capacitor bank voltage exceeded the Overvoltage limit with FET bridge enabled Effect: Reduced Brake Torque Possible Cause:</p> <ul style="list-style-type: none"> • Normal operation. Fault shows that regen braking currents elevated the battery voltage during regen braking. Controller performance limited at this voltage. • Battery menu parameters are misadjusted • Battery resistance too high for given regen current. • Battery disconnected while regen braking • See Monitor menu >> Battery: Capacitor Voltage 	X
4475	POWER MODULE - BDI FAULT	None	4_4	<ul style="list-style-type: none"> • Drive State = PREVENTED • Lift Up State = PREVENTED 	<p>Curtis Code 96: Pump BDI Fault Set: BDI Percentage charge at 0% when the pump was activated. Effect: ShutdownPump Possible Cause:</p> <ul style="list-style-type: none"> • Battery is fully discharged • BDI parameters are mis-tuned 	X
4476	BATTERY VOLTAGE TOO HIGH – UNPLUG CHARGER	None	4_4	<ul style="list-style-type: none"> • Enter Safe Mode • Lift Down State = MAX 	<p>The Ground Module momentarily measured excessively high battery voltage (VBAT) (>32.0V) and entered SafeMode to protect system devices. This may be due to improper battery charging or incorrect voltage batteries being used.</p> <ul style="list-style-type: none"> • The Ground Module measured battery voltage greater than 32.0V and ChargeInterlockState = TRUE. • Main Line Contactor and Battery Relay should be de-energized • Suppress all Help Messages caused by the lack of system power. 	X

Table 7-1. Diagnostic Trouble Codes (DTC)

DTC	Help Message	Alarm	Flash Code	Action	Trigger	R3246/ R2632
4477	BATTERY VOLTAGE TOO HIGH – FORCING DISCHARGE	None	4_4	<ul style="list-style-type: none"> • Disable VSW, Lift Down State = PREVENTED • Lift Up State = PREVENTED • Drive State = PREVENTED suppress other system errors, then Energize STEER_R_VLV and STEER_L_VLV and monitor VBAT 	<p>The Ground Module momentarily measured excessively high battery voltage (VBAT) (>32.0V) and entered SafeMode. This may be due to improper battery charging or incorrect voltage batteries being used.</p> <ul style="list-style-type: none"> • The Ground Module measured battery voltage greater than 32.0V and ChargeInterlockState = FALSE. • System Devices powered by VSW will be disabled • Suppress all DTC Messages caused by the lack of system power. (Pump Module, Platform Module, Tilt Sensors, LSS, and Pot-Hole Protection) • GM shall energize STEER_L_VLV and STEER_R_VLV in an effort to lower float charge down below 31V to get to normal operation state. • If VBAT reading does not go below 31V after 10 seconds, GM shall denenergize the STEER_L_VLV and STEER_R_VLV and latch DTC 442. • If VBAT reading does go below 31V before 10 seconds, GM shall enable VSW and resume with normal startup procedure. 	X
4478	GROUND MODULE - OVERCURRENT	None	4_4	<ul style="list-style-type: none"> • Enter Safe Mode • Lift Down State = MAX 	<p>The current being measured through the Ground Module is too high.</p> <ul style="list-style-type: none"> • The Ground Module measure more than 8 Amps through the VSW switch. 	X
6649	CANBUS FAILURE – TILT/TEMP SENSOR	None	6_6	<ul style="list-style-type: none"> • Tilted State= TRUE • Low Temp Cut=TRUE if {MACHINE SETUP->TEMP CUT-OUT = YES} 	<p>The control system failed to receive messages from the tilt sensor.</p> <ul style="list-style-type: none"> • Tilt Sensor CAN communication not received for 1000ms • Temp Sensor considered to be unhealthy if Low Temperature Cutout configured 	X
7725	PUMP MOTOR - NOT RESPONDING	None	7_7	<ul style="list-style-type: none"> • Drive State = PREVENTED • Lift Up State = PREVENTED 	<p>The control system received Curtis Code 52: Pump Not Responding. This fault is triggered when less than 10A of pump current is measured when PWM is greater than 0%.</p>	X
8212	LSS PRESSURE SENSOR DISAGREEMENT	None	8_2	<ul style="list-style-type: none"> • Lift Up State = PREVENTED if Platform Height Value? LSS Min Height. 	<p>Pressure Sensor 1 (Pressure1Value) and Pressure Sensor 2 (Pressure2Value) do not agree. The control system shall use the worst case Pressure Transducer to determine whether OverLoad State = TRUE.</p> <p>Only applicable if {MACHINE SETUP->LOAD ≠ NO}.</p> <ul style="list-style-type: none"> • Pressure sensor disagreement shall be defined as a pressure difference between Pressure1Value and Pressure2Value greater than 75 PSI for 500ms. • This fault shall be suppressed if DTC 23196/23197/23198/23199 are active. 	X

SECTION 7 - DIAGNOSTIC TROUBLE CODES

Table 7-1. Diagnostic Trouble Codes (DTC)

DTC	Help Message	Alarm	Flash Code	Action	Trigger	R3246/ R2632
8214	LSS ANGLE SENSOR – OUT OF RANGE HIGH	None	8_2	<ul style="list-style-type: none"> • Lift Up State = PREVENTED • Platform Height Value assumed to be Full Elevation for the purposes of other interlocks • Arm Guard Functionality shall be disabled • Latch DTC 252 to require re-calibration of Angle Sensors 	<p>The Elevation1RawValue reading when the machine is at maximum elevation has deviated from the Elevation1MaxCalValue.</p> <p>Only applicable if {MACHINESETUP->LOAD?NO}.</p> <ul style="list-style-type: none"> • Elevation1RawValue > (Elevation1MaxCal-Value +.2V) • This fault shall be suppressed if DTC 825 LSS HAS NOT BEEN CALIBRATED fault is active. • This fault shall be suppressed if DTC 252 ELEV ANGLE SENSOR HAS NOT BEEN CALIBRATED fault is active. • This fault shall be suppressed if the elevation sensor is deemed to be unhealthy (DTCs 252, 2512, 251, 447, or 23205 active). 	X
8215	LSS ANGLE SENSOR – OUT OF RANGE LOW	None	8_2	<ul style="list-style-type: none"> • Lift Up State = PREVENTED • Platform Height Value assumed to be Full Elevation for the purposes of other interlocks • Arm Guard Functionality shall be disabled • Latch DTC 252 to require re-calibration of Angle Sensors 	<p>The Elevation1RawValue reading when the machine is at minimum elevation has deviated from the Elevation1MinCalValue.</p> <p>Only applicable if {MACHINESETUP->LOAD≠NO}.</p> <ul style="list-style-type: none"> • Elevation1RawValue < (Elevation1MinCal-Value -.2V) • This fault shall be suppressed if DTC 825 LSS HAS NOT BEEN CALIBRATED fault is active. • This fault shall be suppressed if DTC 252 ELEV ANGLE SENSOR HAS NOT BEEN CALIBRATED fault is active. • This fault shall be suppressed if the elevation sensor is deemed to be unhealthy (DTCs 252, 2512, 251, 447, or 23205 active). 	X
8217	LSS - OUT OF CALIBRATION	None	8_2	<ul style="list-style-type: none"> • Overload State= TRUE 	<p>Only applicable when {MACHINE SETUP -> LOAD is CUTOFF PLTM or CUTOFF ALL} AND {MACHINE SETUP --> LOAD CFG = PRESSURE}.</p> <p>The Load Sensing System has failed verification. Cycle power and follow calibration procedure to clear the message.</p>	X
8523	LIFT CYLINDER HEAD PRESSURE 1 - OUT OF RANGE HIGH	None	8_5	<ul style="list-style-type: none"> • Overload State= TRUE • Disable VSHORT FET 	<p>Pressure1RawValue is greater than 22.0mA for 500mS.</p> <p>Only applicable if {MACHINE SETUP->LOAD = CUTOFF ALL or CUTOFF PLTM} AND {MACHINE SETUP -->LOAD CFG = PRESSURE}</p> <p>Ignored if machine is in SAFE MODE</p>	X

Table 7-1. Diagnostic Trouble Codes (DTC)

DTC	Help Message	Alarm	Flash Code	Action	Trigger	R3246/ R2632
8524	LIFT CYLINDER HEAD PRESSURE 1 - OUT OF RANGE LOW	None	8_5	• Overload State= TRUE	Pressure1RawValue is less than 3.5mA for 500mS. Only applicable if {MACHINE SETUP-> LOAD = CUTOUT ALL or CUTOUT PLTM} AND {MACHINE SETUP --> LOAD CFG = PRESSURE} and {MACHINE SETUP --> MODEL = 1532R, 1932R, 2632R, or 3247R} Ignored if machine is in SAFE MODE	X
8525	LIFT CYLINDER HEAD PRESSURE 2 - OUT OF RANGE HIGH	None	8_5	• Overload State= TRUE • Disable VSHORT FET	Pressure2RawValue is greater than 22.0mA for 500mS. Only applicable if {MACHINE SETUP-> LOAD = CUTOUT ALL or CUTOUT PLTM} AND {MACHINE SETUP --> LOAD CFG = PRESSURE} AND {MACHINE SETUP --> MODEL = 1532R, 1932R, 2632R, or 3247R} Ignored if machine is in SAFE MODE	X
8526	LIFT CYLINDER HEAD PRESSURE 2 - OUT OF RANGE LOW	None	8_5	• Overload State= TRUE	Pressure2RawValue is less than 3.5mA for 500mS. Only applicable if {MACHINE SETUP-> LOAD = CUTOUT ALL or CUTOUT PLTM} AND {MACHINE SETUP --> LOAD CFG = PRESSURE} AND {MACHINE SETUP --> MODEL is 1532R, 1932R, 2632R, or 3247R} Ignored if machine is in SAFE MODE	X
8527	LIFT CYLINDER HEAD PRESSURE - DISAGREEMENT	None	8_5	• Overload State= TRUE	<ul style="list-style-type: none"> • {MACHINE SETUP --> MODEL is 2632R, or 3247R} • {MACHINE SETUP-> LOAD = CUTOUT PLTM or CUTOUT ALL} • {MACHINE SETUP --> LOAD CFG = PRESSURE} • ABS [Pressure1Value - Pressure2Value] greater than 180 PSI for 500ms • DTC 8523, 8524, 8525, 8526 are not active • Ignored if machine is in SAFE MODE 	X
8528	LIFT CYLINDER ROD PRESSURE 1 - OUT OF RANGE HIGH	None	8_5	• Overload State= TRUE	Pressure3RawValue is greater than 4.75V for 500mS. Only applicable if {MACHINE SETUP-> LOAD = CUTOUT ALL or CUTOUT PLTM} AND {MACHINE SETUP --> LOAD CFG = PRESSURE}	X
8529	LIFT CYLINDER ROD PRESSURE 1 - OUT OF RANGE LOW	None	8_5	• Overload State= TRUE	Pressure3RawValue is less than 0.25V for 500mS. Only applicable if {MACHINE SETUP-> LOAD = CUTOUT ALL or CUTOUT PLTM} AND {MACHINE SETUP --> LOAD CFG = PRESSURE}	X

SECTION 7 - DIAGNOSTIC TROUBLE CODES

Table 7-1. Diagnostic Trouble Codes (DTC)

DTC	Help Message	Alarm	Flash Code	Action	Trigger	R3246/ R2632
8532	LIFT CYLINDER ROD PRESSURE - DISAGREEMENT	None	8_5	• Overload State= TRUE	<ul style="list-style-type: none"> • Pressure3RawValue is greater than 50PSI for 10,000mS (both ConstantData) while all of the following are true: • PlatformHeightValue stable within 2.0 in. (ConstantData) • Drive not active • Lift not active • Steer not active • Machine Setup --> LOAD is CUTOUT ALL or CUTOUT PLTM • MACHINE SETUP --> LOAD CFG = PRESSURE • DTC 8528 not active • DTC 8529 not active 	X
9910	FUNCTIONS LOCKED OUT – PLATFORM MODULE SOFTWARE VERSION IMPROPER	None	9_9	If Platform Mode <ul style="list-style-type: none"> • Drive State = PREVENTED • Lift Up State = PREVENTED • Lift Down State = PREVENTED 	The control system will not function in Platform-Mode because the Platform Module Software Version is not compatible with the rest of the system. Re-program or replace with a Version 1.xx module. <ul style="list-style-type: none"> • The Platform Module reported two consecutive Software Major Versions that were not equal to "1" while in PlatformMode. The control system may resume operation once the difficulty has been corrected. • This fault shall only be active when output V5-6 is energized. 	X
9911	FUNCTIONS LOCKED OUT – LSS MODULE SOFTWARE VERSION IMPROPER	Latched	Latched	• Overload State= TRUE	The control system will not function because the LSS Module Software Version is not compatible with the rest of the system. Re-program or replace with a Version 7.xx module <ul style="list-style-type: none"> • {MACHINE SETUP --> LOAD ≠ NO} AND {MACHINE SETUP --> LOAD CFG = LOAD CELL} • Machine Setup's LOAD=1 or 2 AND the LSS Module reported a Software Major Version that was not equal to "7". The control system may resume operation once the difficulty has been corrected 	X
9912	POWER MODULE FAILURE - SYSTEM MONITOR	None	9_9	<ul style="list-style-type: none"> • Drive State = PREVENTED • Lift Up State = PREVENTED 	<p>Curtis Code 77: Supervision Fault</p> <p>Set: Supervisor logic fails?</p> <p>Effect: ShutdownMotor, Shutdown Main Contactor, ShutdownEMBrake, ShutdownThrottle, FullBrake, ShutdownPump</p>	X

Table 7-1. Diagnostic Trouble Codes (DTC)

DTC	Help Message	Alarm	Flash Code	Action	Trigger	R3246/ R2632
9924	FUNCTIONS LOCKED OUT – MACHINENOT CONFIGURED	None	9_9	<ul style="list-style-type: none"> • Drive State = PREVENTED • Lift Up State = PREVENTED • Lift Down State = PREVENTED 	<p>The Ground Module has not been configured for the first time. Use the JLG Analyzer to adjust all Machine Setup and Personality settings and re-cycle power to clear difficulty.</p> <ul style="list-style-type: none"> • This fault shall be suppressed if DTC 259 is active. This fault shall only be active if current selection is UNKNOWN or NO MODEL. Otherwise, as long as user changes to a valid selection DTC 259 shall be active • The Ground Module’s non-volatile flag indicates that the vehicle has not been configured (new control system components). Retained until {MACHINE SETUP-> MODEL} and {MACHINE SETUP->MARKET} are selected and power is re-cycled. 	X
9949	MACHINENOT CONFIGURATION OUT OF RANGE – CHECK ALL SETTINGS	Continuously	9_9	<ul style="list-style-type: none"> • Drive State = PREVENTED • Lift Up State = PREVENTED • Lift Down State = PREVENTED 	<p>Ground Module detects one of these issues:</p> <ul style="list-style-type: none"> • Machine Setup parameter or Personality is out of range • Machine Setup checksum improper 	X
9950	POWER MODULE FAILURE – INTERNAL ERROR	None	9_9	<ul style="list-style-type: none"> • Drive State = PREVENTED • Lift Up State = PREVENTED 	<p>Curtis Code 14: Precharge Failed Set: Precharge failed to charge the capacitor bank to the KSI voltage. Effect: ShutdownMotor, Shutdown Main Contactor, ShutdownEMBrake, ShutdownThrottle, FullBrake, ShutdownPump Possible Cause:</p> <ul style="list-style-type: none"> • See Monitor menu>>Battery: Capacitor Voltage • External load on capacitor bank (B+ connection terminal) that prevents the capacitor bank from charging. 	X
9951	POWER MODULE FAILURE – INTERNAL ERROR	None	9_9	<ul style="list-style-type: none"> • Drive State = PREVENTED • Lift Up State = PREVENTED 	<p>Curtis Code 71: OS General Set: Internal controller fault detected Effect: ShutdownMotor, Shutdown Main Contactor, ShutdownEMBrake, ShutdownThrottle, ShutdownDrivers, ShutdownPD FullBrake, ShutdownPump Possible Cause:</p> <ul style="list-style-type: none"> • Internal Controller fault. 	X
9952	POWER MODULE FAILURE – INTERNAL ERROR	None	9_9	<ul style="list-style-type: none"> • Drive State = PREVENTED • Lift Up State = PREVENTED 	<p>Curtis Code 43: Pump Throttle Wiper High Set: Pot2 wiper voltage is lower than the high fault threshold (can be changed with the VCL function Setup_Pot_Faults()) Effect: ShutdownPump (if Lift_Switch_Only_Enable=Off), ShutdownPD (if Lower_Switch_Only_Enable=Off) Possible Cause:</p> <ul style="list-style-type: none"> • See Monitor Menu>> Inputs: Pot2 Raw • Pot2 wiper voltage too high 	X

SECTION 7 - DIAGNOSTIC TROUBLE CODES

Table 7-1. Diagnostic Trouble Codes (DTC)

DTC	Help Message	Alarm	Flash Code	Action	Trigger	R3246/ R2632
9953	POWER MODULE FAILURE – INTERNAL ERROR	None	9_9	<ul style="list-style-type: none"> • Drive State = PREVENTED • Lift Up State = PREVENTED 	<p>Curtis Code 97: Pump Hardware Fault Set: Controller hardware indicated inappropriate voltage at pump motor M- connection, or internal supply voltage problem. Effect: ShutdownMotor, Shutdown Main Contactor, ShutdownEMBrake, ShutdownThrottle, FullBrake, ShutdownPump Possible Cause:</p> <ul style="list-style-type: none"> • External short of the pump motor • Controller defective 	X
9954	POWER MODULE FAILURE – INTERNAL ERROR	None	9_9	<ul style="list-style-type: none"> • Drive State = PREVENTED • Lift Up State = PREVENTED 	<p>Curtis Code 47: Pump HPD Fault Set: Incorrect sequence of KSI and lift, lower, or hydraulic throttle inputs according to Hyd_Inhibit_Type parameter. Effect: ShutdownPump Possible Cause:</p> <ul style="list-style-type: none"> • KSI and Hydraulic throttle input applied in incorrect sequence; hydraulic throttle input was active when KSI was turned on. • Fault wiring, crimps, or switches at KSI, lift, lower, or hydraulic throttle inputs. • See Monitor menu>> Inputs 	X
9955	POWER MODULE FAILURE – INTERNAL ERROR	None	9_9	<ul style="list-style-type: none"> • Drive State = PREVENTED • Lift Up State = PREVENTED 	<p>Curtis Code 52: Pump Not Responding Set: Pump current is equal to 0, when it is being commanded to percentage larger than 0% Effect: ShutdownPump Possible Cause:</p> <ul style="list-style-type: none"> • Load is disconnected 	X
9956	POWER MODULE FAILURE – INTERNAL ERROR	None	9_9	<ul style="list-style-type: none"> • Drive State = PREVENTED • Lift Up State = PREVENTED 	<p>Curtis Code 49: Parameter Change Fault Set: Adjustment of a parameter setting that requires cycling of KSI. Effect: ShutdownMotor, ShutdownMainContactor, ShutdownEMBrake, ShutdownThrottle, Full-Brake, ShutdownPump Possible Cause:</p> <ul style="list-style-type: none"> • This is a safety fault caused by a change in certain parameter setting so that the vehicle will not operate until KSI is cycled. For example, if a user changes the Throttle Type this fault will appear and require cycling of KSI before vehicle can operate. 	X

Table 7-1. Diagnostic Trouble Codes (DTC)

DTC	Help Message	Alarm	Flash Code	Action	Trigger	R3246/ R2632
9957	POWER MODULE FAILURE – INTERNAL ERROR	None	9_9	<ul style="list-style-type: none"> • Drive State = PREVENTED • Lift Up State = PREVENTED 	<p>Curtis Code 68: VCL Run Time Error Set: Runtime VCL code error condition Effect: ShutdownMotor, ShutdownMainContactor, ShutdownEMBrake, ShutdownThrottle, Shutdown Interlock, Shutdown Drivers1-4, ShutdownPD, FullBrake, ShutdownPump Possible Cause:</p> <ul style="list-style-type: none"> • VCL code encountered a runtime VCL error • See Monitor menu>>Controller. This error can then be compared to the runtime VCL module ID and error code definitions found in the specific OS system information file. 	X
9958	POWER MODULE FAILURE – INTERNAL ERROR	None	9_9	<ul style="list-style-type: none"> • Drive State = PREVENTED • Lift Up State = PREVENTED 	<p>Curtis Code 91: VCL/OS Mismatch Set: VCL and OS software do not match; when KSI cycles, a check is made to verify that they match and a fault issued when they do not. Effect: ShutdownMotor, ShutdownMainContactor, ShutdownEMBrake, ShutdownThrottle, Shutdown Interlock, Shutdown Drivers1-4, ShutdownPD, FullBrake, ShutdownPump Possible Cause:</p> <ul style="list-style-type: none"> • The VCL software in the controller does not match the OS software in the controller. 	X
9959	POWER MODULE FAILURE – INTERNAL ERROR	None	9_9	<ul style="list-style-type: none"> • Drive State = PREVENTED • Lift Up State = PREVENTED 	<p>Curtis Code 44: Pump Throttle Wiper Low Set: Pot2 wiper voltage is lower than the low fault threshold (can be changed with the VCL function Setup_Pot_Faults()) Effect: ShutdownPump (if Lift_Switch_Only_Enable=Off), ShutdownPD (if Lower_Switch_Only_Enable=Off) Possible Cause:</p> <ul style="list-style-type: none"> • See Monitor Menu>> Inputs: Pot2 Raw • Pot2 wiper voltage too low 	X
23196	PRESSURE SENSOR 1 OUT OF RANGE HIGH		2_3	<ul style="list-style-type: none"> • Overload State= TRUE 	<p>A short to Battery was detected on the PRSTR_SIG1 or reading was >22mA. The Ground module should disable the VSHORT FET to protect the board components.</p> <ul style="list-style-type: none"> • Only applicable if {MACHINE SETUP-> LOAD = CUTOUT ALL or CUTOUT PLTM} 	X
23197	PRESSURE SENSOR 1 OUT OF RANGE LOW		2_3	<ul style="list-style-type: none"> • Lift Up State = PREVENTED 	<p>The Pressure1RawValue is considered out of range low since it is <3.5mA.</p> <ul style="list-style-type: none"> • Only applicable if {MACHINE SETUP-> LOAD = CUTOUT ALL or CUTOUT PLTM} 	X
23198	PRESSURE SENSOR 2 OUT OF RANGE HIGH		2_3	<ul style="list-style-type: none"> • Overload State= TRUE 	<p>A short to Battery was detected on the PRSTR_SIG2 or reading was >22mA. The Ground module should disable the VSHORT FET to protect the board components.</p> <ul style="list-style-type: none"> • Only applicable if {MACHINE SETUP-> LOAD = CUTOUT ALL or CUTOUT PLTM} 	X

SECTION 7 - DIAGNOSTIC TROUBLE CODES

Table 7-1. Diagnostic Trouble Codes (DTC)

DTC	Help Message	Alarm	Flash Code	Action	Trigger	R3246/ R2632
23199	PRESSURE SENSOR 2 OUT OF RANGE LOW		2_3	• Lift Up State = PREVENTED	The Pressure1RawValue is considered out of range low since it is <3.5mA. • Only applicable if {MACHINE SETUP-> LOAD = CUTOUT ALL or CUTOUT PLTM}	X
23200	LIFT UP SWITCH - INVALID SIGNAL		2_3	• Lift Up State = PREVENTED	In Ground Mode and the Ground Module detects a redundancy disagreement on the LIFT_UP_SW input for 500ms. Ignore this fault in Platform Mode.	X
23201	LIFT DOWN SWITCH - INVALID SIGNAL		2_3	• Lift Up State = PREVENTED • Lift Down State = PREVENTED	In Ground Mode and the Ground Module detects a redundancy disagreement on the LIFT_D-N_SW input for 500ms. Ignore this fault in Platform Mode.	X
23202	POT HOLE PREVENTION SWITCH 1 - INVALID SIGNAL		2_3	• Pot-Hole State = BLOCKED	The Ground Module detects a redundancy disagreement on the PHP_SW1 input for 500ms. This error is valid in both Ground Mode and Platform Mode.	X
23203	POT HOLE PREVENTION SWITCH 2 - INVALID SIGNAL		2_3	• Pot-Hole State = BLOCKED	The Ground Module detects a redundancy disagreement on the PHP_SW2 input for 500ms. This error is valid in both Ground Mode and Platform Mode.	X
23204	CHARGE INTERLOCK - INVALID SIGNAL		2_3	• Charge Interlock State = TRUE	The Ground Module detects a redundancy disagreement on the CHARGE_INTRLK input for 500ms. This error is valid in both Ground Mode and Platform Mode.	X
23205	ELEVATION SENSORS - INVALID SIGNAL		2_3	• Lift Up State = PREVENTED • Platform Height Value assumed to be Full Elevation for the purposes of other interlocks • Overload State = TRUE	The control system has detected a disagreement between Elevation Sensor 1 and Elevation Sensor 2. Check the Elevation Sensors and associated wiring. • Only Valid if {MACHINE SETUP->LOAD ≠ NO} AND ROTS1_SIG and ROTS2_SIG are not +/- .25V of the normalized voltage. • This fault shall be suppressed if the DTC 252 ELEVATION SENSORS NOT CALIBRATED fault is active.	X
23238	ELEVATION ANGLE SENSOR MAX ELEVATION - NOT CALIBRATED	None	2_3	• Overload State = TRUE if {MACHINE SETUP->LOAD≠NO}	Successfully complete the SET MAX ELEVATION calibration procedure to clear the message. • The Elevation Sensor was not calibrated at max elevation	X
33208	HORN - SHORT TO BATTERY	None	3_3	• Disable Output	Short to Battery was detected on GRND_ALARM_SIG	X
33209	HORN SHORT TO GROUND	None	3_3	• Disable Output	Short to Ground was detected on GRND_ALARM_SIG. Short to ground output shall be STG when the following conditions are present: • A2D counts are >= 200 while PWM output is greater than 25% (Constant Data) • Conditions must be present for 500 ms (Constant Data)	X
33298	STEER LEFT VALVE – SHORT TO GROUND	None	3_3	• Disable Output • Drive State = PREVENTED	Short to Ground was detected on STEER_L_VLV	X

Table 7-1. Diagnostic Trouble Codes (DTC)

DTC	Help Message	Alarm	Flash Code	Action	Trigger	R3246/ R2632
33299	LINE CONTACTOR COIL – SHORT TO BATTERY	None	3_3	• Enter Safe Mode	The Ground Module has been powered up due to a wiring fault since neither the Ground Mode or Platform Mode Digital input are Energized. This could be due to the VON pin being shorted to battery. • Ground Module is powered but both V4-20 PF_SEL and V1-5 GRND_SEL are read as de-energized.	X
33305	STEER RIGHT VALVE – SHORT TO GROUND	None	3_3	• Disable Output • Drive State = PREVENTED	Short to Ground was detected on STEER_R_VLV	X
33317	DRIVE FORWARD VALVE – OPEN CIRCUIT	None	3_3	• Disable Output • Drive State = PREVENTED	Open Circuit detected on DRIVE_FWD_VLV	X
33318	DRIVE FORWARD VALVE – SHORT TO BATTERY	None	3_3	• Disable Output • Lift Up State = PREVENTED • Drive State = PREVENTED	Short to Battery was detected on DRIVE_FWD_VLV	X
33319	DRIVE FORWARD VALVE – SHORT TO GROUND	None	3_3	• Disable Output • Drive State = PREVENTED	Short to Ground was detected on DRIVE_FWD_VLV	X
33320	DRIVE REVERSE VALVE – OPEN CIRCUIT	None	3_3	• Disable Output • Drive State = PREVENTED	Open Circuit detected on DRIVE_REV_VLV	X
33321	DRIVE REVERSE VALVE – SHORT TO BATTERY	None	3_3	• Disable Output • Drive State = PREVENTED • Lift Up State = PREVENTED	Short to Battery was detected on DRIVE_REV_VLV	X
33322	DRIVE REVERSE VALVE – SHORT TO GROUND	None	3_3	• Disable Output • Drive State = PREVENTED	Short to Ground was detected on DRIVE_REV_VLV	X
33383	BEACON LIGHT – OPEN CIRCUIT	None	3_3	• Disable output • No motion restrictions	Open Circuit was detected on BEACON AND {MACHINE SETUP-> BEACON= YES}. • This only detectable during Armguard, since that is the only time that the BEACON is disabled when {MACHINE SETUP-> BEACON= YES}.	X
33384	BEACON LIGHT – SHORT TO GROUND	None	3_3	• Disable output • No motion restrictions	Short to Ground was detected on BEACON AND {MACHINE SETUP-> BEACON= YES}.	X
33406	LIFT UP VALVE – SHORT TO GROUND	None	3_3	• Disable Output • Lift Up State = PREVENTED	Short to Ground was detected on LIFT_UP_VLV	X
33407	LIFT DOWN VALVE – SHORT TO GROUND	None	3_3	• Disable High side Output • Open Low side Output • Lift Down State = PREVENTED • Lift Up State = PREVENTED	Short to Ground was detected on LIFT_DN_VLV when all the following conditions are true: • Low Side FET enabled • PWM is > 45% duty cycle • High Side Feedback < 10 counts • Low Side Current Feedback < 50 mA	X
33537	AUXILIARY LIFT DOWN VALVE - SHORT TO GROUND	None	3_3	• Disable High side Output • Open Low side Output • Lift Down State = CREEP • Lift Up State = CREEP	Short to Ground was detected on LIFT_DN_VLV_2 AND {MACHINE SETUP-> MODEL->4045R} when all the following conditions are true: • Low Side FET enabled • PWM is > 45% duty cycle • High Side Feedback < 10 counts • Low Side Current Feedback < 50 mA	X

SECTION 7 - DIAGNOSTIC TROUBLE CODES

Table 7-1. Diagnostic Trouble Codes (DTC)

DTC	Help Message	Alarm	Flash Code	Action	Trigger	R3246/ R2632
33538	AUXILIARY LIFT DOWN VALVE - OPEN CIRCUIT	None	3_3	<ul style="list-style-type: none"> • Disable High side Output • Open Low side Output • Lift Down State = CREEP • Lift Up State = CREEP 	Open Circuit detected on LIFT_DN_VLV_2 AND {MACHINE SETUP-> MODEL->4045R} <ul style="list-style-type: none"> • The valve PWM rate needs to be zero • The feedback on the PWM output needs to be > 45% of battery voltage • The conditions must exist for 250 mS 	X
33539	AUXILIARY LIFT DOWN VALVE - SHORT TO BATTERY	None	3_3	<ul style="list-style-type: none"> • Disable High side Output • Open Low side Output • Lift Down State = CREEP • Lift Up State = CREEP 	Short to Battery was detected on LIFT_DN_VLV_2 AND {MACHINE SETUP-> MODEL->4045R}	X
33562	BEACON LIGHT – SHORT TO BATTERY	None	3_3	<ul style="list-style-type: none"> • Disable output • No motion restrictions 	Short to Battery was detected on BEACON AND {MACHINE SETUP-> BEACON=YES}. <ul style="list-style-type: none"> • This will only be triggered when ARMGUARD is active and the short to battery occurs under the Arm guard limit. 	X
33674	PLATFORM POWER – SHORT TO BATTERY	None	3_3	<ul style="list-style-type: none"> • Force Ground Mode • Disable output 	Short to Battery was detected on the PLATFORM_PWR digital output.	X
33675	PLATFORM POWER – OPEN CIRCUIT	None	3_3	<ul style="list-style-type: none"> • N/A 	Ignore this fault for following reasons. <ul style="list-style-type: none"> • N/A in Ground Mode • No diagnostic value in Platform Mode, would only increase startup time. 	X
33676	PLATFORM POWER – SHORT TO GROUND	None	3_3	<ul style="list-style-type: none"> • PlatformMode Prevented • Disable output 	Short to Ground was detected on the PLATFORM_PWR digital output.	X
33735	AUXILIARY LIFT DOWN VALVE - CURRENT FEEDBACK READING TOO LOW	None	3_3	<ul style="list-style-type: none"> • Normal operation 	Current Reading Too Low was detected on LIFT_DN_VLV_2 <ul style="list-style-type: none"> • Low Side FET enabled • PWM is > 45% duty cycle • High Side Feedback > 10 counts • Low Side Current Feedback < 250 mA • MACHINE SETUP-> MODEL= 4045R 	X
33739	LIFT DOWN VALVE - CURRENT FEEDBACK READING TOO LOW	None	3_3	<ul style="list-style-type: none"> • Normal operation 	Current Reading Too Low was detected on LIFT_DN_VLV <ul style="list-style-type: none"> • Low Side FET enabled • PWM is > 45% duty cycle • High Side Feedback > 10 counts • Low Side Current Feedback < 250 mA 	X
99162	EEPROM FAILURE POWER MODULE - CHECK ALL SETTINGS	None	9_9	<ul style="list-style-type: none"> • Drive State = PREVENTED • Lift Up State = PREVENTED 	<p>Curtis Code 46: EEPROM Failure</p> <p>Set: Controller operating system tried to write to EEPROM memory and failed.</p> <p>Effect: ShutdownMotor, ShutdownMainContactor, ShutdownEMBrake, ShutdownThrottle, ShutdownInterlock, Shutdown Drivers1-4, ShutdownPD, FullBrake, ShutdownPump</p> <p>Possible Cause:</p> <ul style="list-style-type: none"> • Failure to write to EEPROM memory. This can be caused by EEPROM memory writes initiated by VCL, by the CAN bus, by adjusting parameters with the programmer, or by loading new software into the controller. 	X

SECTION 8. BASIC ELECTRICAL INFORMATION & SCHEMATICS

8.1 GENERAL

This section contains schematics to be used for locating and correcting most of the operating problems which may develop. If a problem should develop which is not presented in this section or which is not corrected by listed corrective actions, technically qualified guidance should be obtained before proceeding with any maintenance.

NOTICE

IT IS A GOOD PRACTICE TO AVOID PRESSURE WASHING ELECTRICAL/ELECTRONIC COMPONENTS. SHOULD PRESSURE WASHING BE UTILIZED TO WASH AREAS CONTAINING ELECTRICAL/ELECTRONIC COMPONENTS, JLG INDUSTRIES, INC. RECOMMENDS A MAXIMUM PRESSURE OF 750 PSI (52 BAR) AT A MINIMUM DISTANCE OF 12 IN. (30.5 CM) AWAY FROM THESE COMPONENTS. IF ELECTRICAL/ELECTRONIC COMPONENTS ARE SPRAYED, SPRAYING MUST NOT BE DIRECT AND BE FOR BRIEF TIME PERIODS TO AVOID HEAVY SATURATION.

8.2 MULTIMETER BASICS

A wide variety of multimeters or Volt Ohm Meters (VOM) can be used for troubleshooting your equipment. A digital meter with reasonable accuracy (within 7%) is recommended for the measurements in these procedures. This section shows diagrams of a common, digital VOM configured for several different circuit measurements. Instructions for your VOM may vary. Please consult the meter operator's manual for more information.

Grounding

"Grounding the meter" means to take the black lead (which is connected to the COM (common) or negative port) and touch it to a good path to the negative side of the voltage source.

Backprobing

To "backprobe" means to take the measurement by accessing a connector's contact on the same side as the wires, the back of the connector. Readings can be done while maintaining circuit continuity this way. If the connector is the sealed type, great care must be taken to avoid damaging the seal around the wire. It is best to use probes or probe tips specifically designed for this technique, especially on sealed connectors. Whenever possible insert probes into the side of the connector such that the test also checks both terminals of the connection. It is possible to inspect a connection within a closed connector by backprobing both sides of a connector terminal and measuring resistance. Do this after giving each wire a gentle pull to ensure the wires are

still attached to the contact and contacts are seated in the connector.

Min/Max

Use of the "Min/Max" recording feature of some meters can help when taking measurements of intermittent conditions while alone. For example, you can read the voltage applied to a solenoid when it is only operational while a switch, far from the solenoid and meter, is held down.

Polarity

Finding a negative voltage or current reading when expecting a positive reading frequently means the leads are reversed. Check what reading is expected, the location of the signal and that the leads are connected to the device under test correctly. Also check that the lead on the "COM" port goes to the ground or negative side of the signal and the lead on the other port goes to the positive side of the signal.

Scale

M = Mega = 1,000,000 * (Displayed Number)

k = kilo = 1,000 * (Displayed Number)

m = milli = (Displayed Number) / 1,000

μ = micro = (Displayed Number) / 1,000,000

Example: 1.2 k Ω = 1200 Ω

Example: 50 mA = 0.05 A

Voltage Measurement

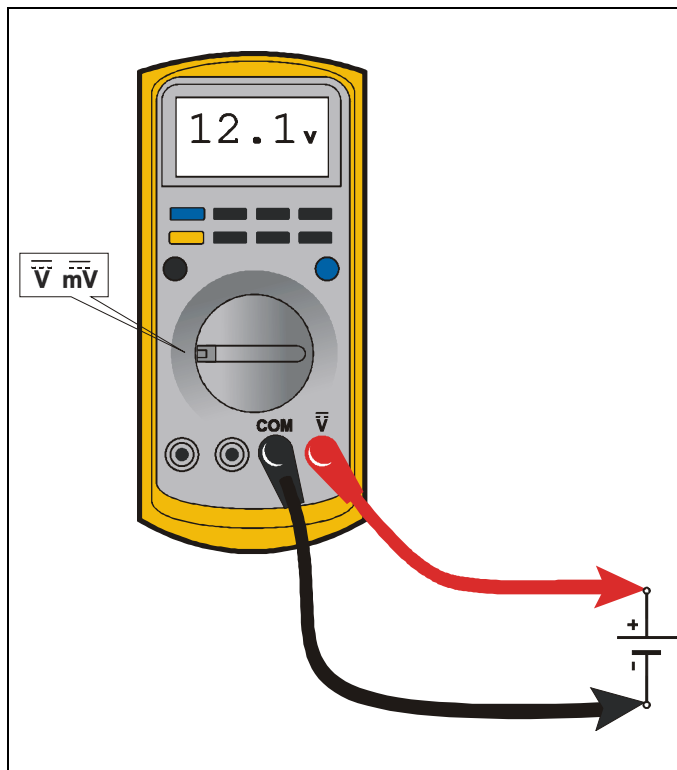

- If meter is not auto ranging, set it to the correct range (See multimeter's operation manual).
- Use firm contact with meter leads.

Resistance Measurement

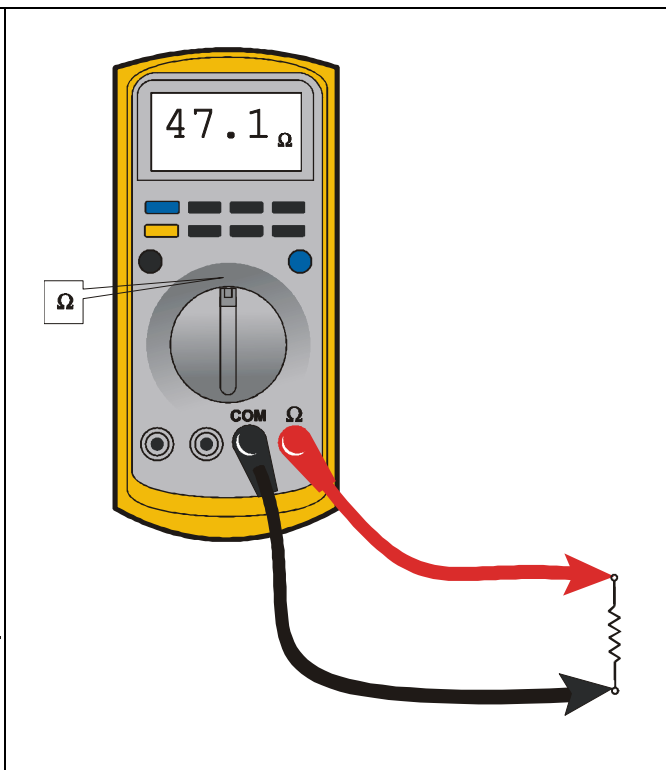

- First test meter and leads by touching leads together. Resistance should read a short circuit (very low resistance).
- Circuit power must be turned OFF before testing resistance.
- Disconnect component from circuit before testing.
- If meter is not auto ranging, set it to the correct range (See multimeter's operation manual).
- Use firm contact with meter leads.

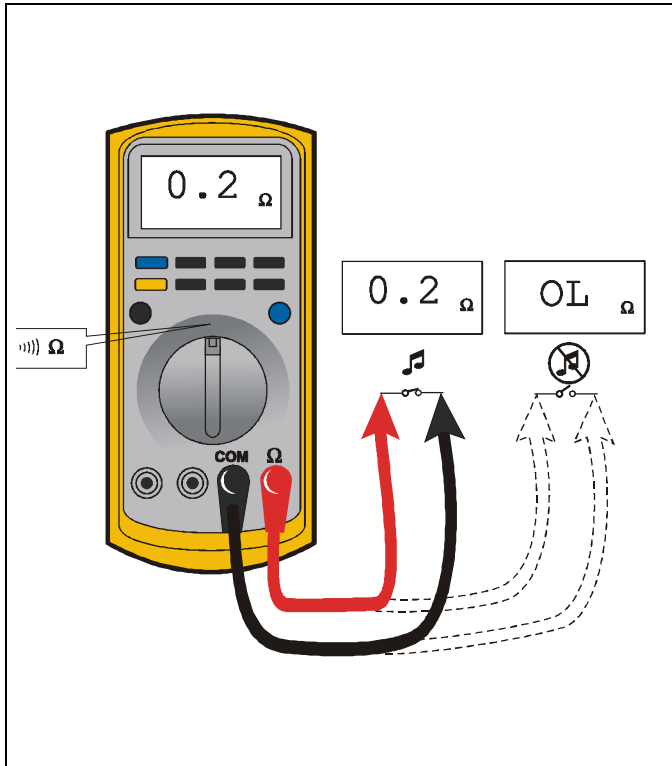
Continuity Measurement

- Some meters require a separate button press to enable audible continuity testing.
- Circuit power must be turned OFF before testing continuity.
- Disconnect component from circuit before testing.
- Use firm contact with meter leads.
- First test meter and leads by touching leads together. Meter should produce an audible alarm, indicating continuity.

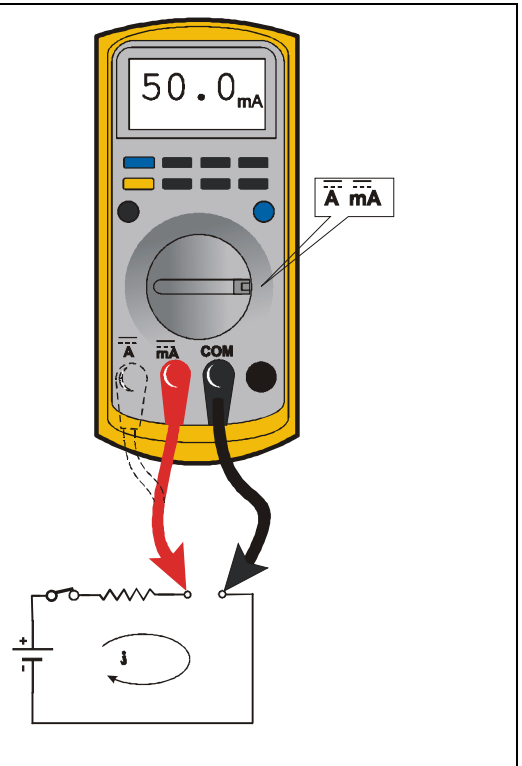
Current Measurement

- Set up the meter for the expected current range.
- Be sure to connect the meter leads to the correct jacks for the current range you have selected.
- If meter is not auto ranging, set it to the correct range (See multimeter's operation manual).
- Use firm contact with meter leads.

Continuity Measurement Over Long Distances

When trying to determine continuity of a harness or wire, longer than the reach of standard instrument leads, is possible to perform the check without excessively long leads. Using the other wires in the harness one can determine the condition of a particular wire in the harness.

Requirements:

- Harness with at least three separate wires including the wire under test.
- These wires must be able to be isolated from other wires, etc.
- Jumper or method to connect contacts on one side of harness.
- Meter that can measure resistance or continuity.

Procedure

Test multimeter leads resistance. Subtract this value from the measured resistance of the wires to get a more accurate measurement. Consult the circuit schematic to determine which wires to use in addition to wire under test, here called wire #1 and wire #2, and how to isolate these wires. These wires should appear in the same connectors as the wire under test or are within reach of the jumper.

1. Disconnect all connections associated with the wire under test and the two additional wires. If harness is not completely isolated disconnect battery terminals also, as a precaution.
2. Measure continuity between all three wires, the wire under test, wire #1 and wire #2. These should be open. If not, repair the shorted wires or replace the harness.
3. On one side, jumper from contact of wire #1 and wire #2.
4. Measure continuity between wire #1 and wire #2. If there is continuity, both wires are good and can be used for this test. If there is not continuity, either wire could be bad. Check connections and measurement setup. Redo measurement. If still no continuity, repair wires or consult schematic for other wires to use for test.
5. Jumper from wire under test to wire #1.
6. Measure continuity. If there is continuity, the wire under test is good. Resistance of a wire increases as the length increases and as the diameter decreases.

One can find the continuity of two wires, here #1 and #2, at once by following steps 1 through 4. If there is a problem the third wire is used to troubleshoot the other wires. To find the problem, start at step 1 and use the entire procedure.

8.3 APPLYING SILICONE DIELECTRIC COMPOUND TO AMP CONNECTORS

Silicone Dielectric Compound must be used on the AMP connections for the following reasons:

- To prevent oxidation at the mechanical joint between male and female pins.
- To prevent electrical malfunction caused by low level conductivity between pins when wet.

Use the following procedure to apply Silicone Dielectric Compound to the electrical connectors.

1. To prevent oxidation and low level conductivity, silicone dielectric grease must be packed completely around male and female pins on the inside of the connector after the mating of the housing to the header. This is easily achieved by using a syringe to fill the header with silicone dielectric compound, to a point just above the top of the male pins inside the header. When assembling the housing to the header, it is possible that the housing will become air locked, thus preventing the housing latch from engaging.
2. Pierce one of the unused wire seals to allow the trapped air inside the housing to escape.
3. Install a hole plug into this and/or any unused wire seal that has silicone dielectric compound escaping from it.

8.4 DIELECTRIC GREASE APPLICATION

Dielectric grease helps to prevent corrosion of electrical contacts and improper conductivity between contacts from moisture intrusion. Non-waterproof connectors benefit from the application of dielectric grease.

Installation

The following is general guidance for the installation of dielectric grease in a connector system.

- Use dielectric grease in a tube for larger connection points or apply with a syringe for small connectors.
- Apply dielectric grease to plug/male connector housing which typically contains sockets contact/female terminals.
- Leave a layer of dielectric grease on the mating face of the connector, completely covering each connector terminal hole. Refer the pictures shown below.
- Assemble the connector system immediately to prevent moisture ingress or dust contamination.

The following connector systems are specifically addressed because of their widespread use at JLG. However, this guidance may be applied to similar devices.

AMP Mate-N-Lok

This connector system is widely used inside enclosures for general-purpose interconnect. Follow the general guidance for installation.

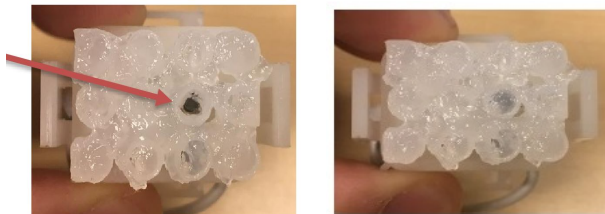

Improper

Proper

AMP Faston

This connector system is typically used on operator switches at JLG. Follow the general guidance for installation.



Improper

Proper

AMP Micro-Fit

This connector system is typically used on control modules at JLG. Follow the general guidance for installation.

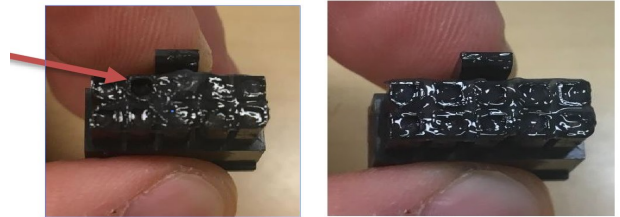

Improper

Proper

AMP Mini Fit Jr

This connector system is typically used on control modules at JLG. Follow the general guidance for installation.

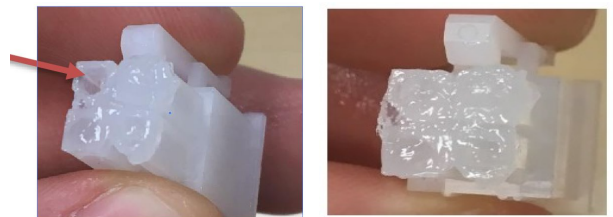

Improper

Proper

Mini Fit Sr

This connector system is typically used on control modules at JLG. Follow the general guidance for installation.

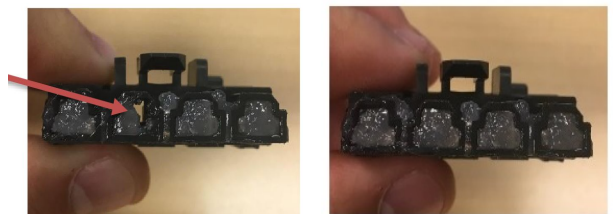

Improper

Proper

DIN Connectors

This connector is typically used on hydraulic valves. Follow the installation instructions

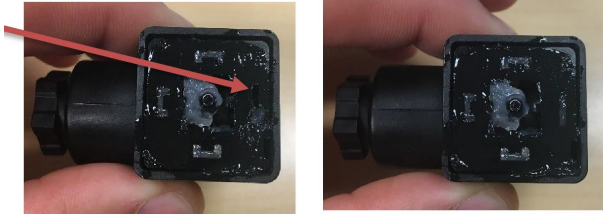

Improper

Proper

Exceptions

Some waterproof connector applications do benefit from dielectric grease, and some non waterproof connectors do not benefit from dielectric grease.

In the exceptions below, we have found dielectric grease is not needed for some applications, and in some cases can interfere with the intended connection. Dielectric grease shall be used as an exception in other applications.

Enclosures

Application of dielectric grease is not required in properly sealed enclosures. To meet criteria, the enclosure must be rated to at least IP56 (dust protected; protected from powerful jets of water).

Carling Switch Connectors

Carling switches may experience high impedance, or discontinuity, due to silicone dielectric grease ingress when switching inductive loads. Therefore, dielectric grease shall not be applied to Carling switch mating connectors unless specifically noted.

Scissor Platform Cable at the Platform Control

Some waterproof connectors are exposed to the elements when disconnected by the customer benefit from having protection using dielectric grease.



8.5 AMP CONNECTOR

Assembly

Check to be sure the wedge lock is in the open, or as-shipped, position (See Figure 8-1.). Proceed as follows:

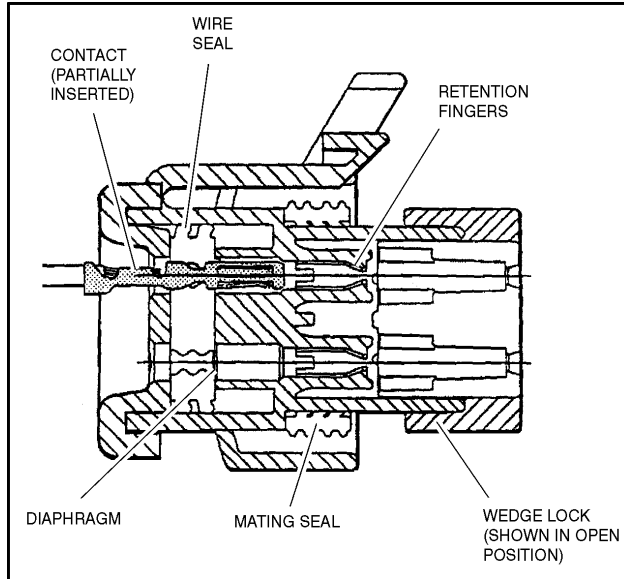

Figure 8-1. Connector Assembly Figure 1

1. To insert a contact, push it straight into the appropriate circuit cavity as far as it will go (See Figure 8-3.).
2. Pull back on the contact wire with a force of 1 or 2 lbs. to be sure the retention fingers are holding the contact (See Figure 8-3.).

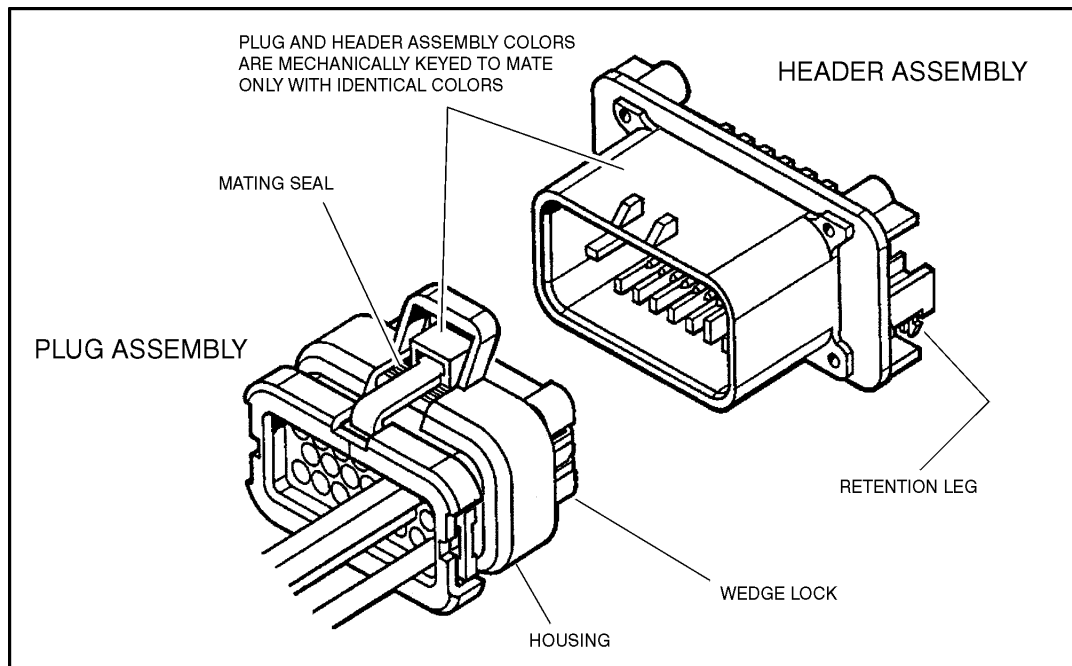

Figure 8-2. AMP Connector

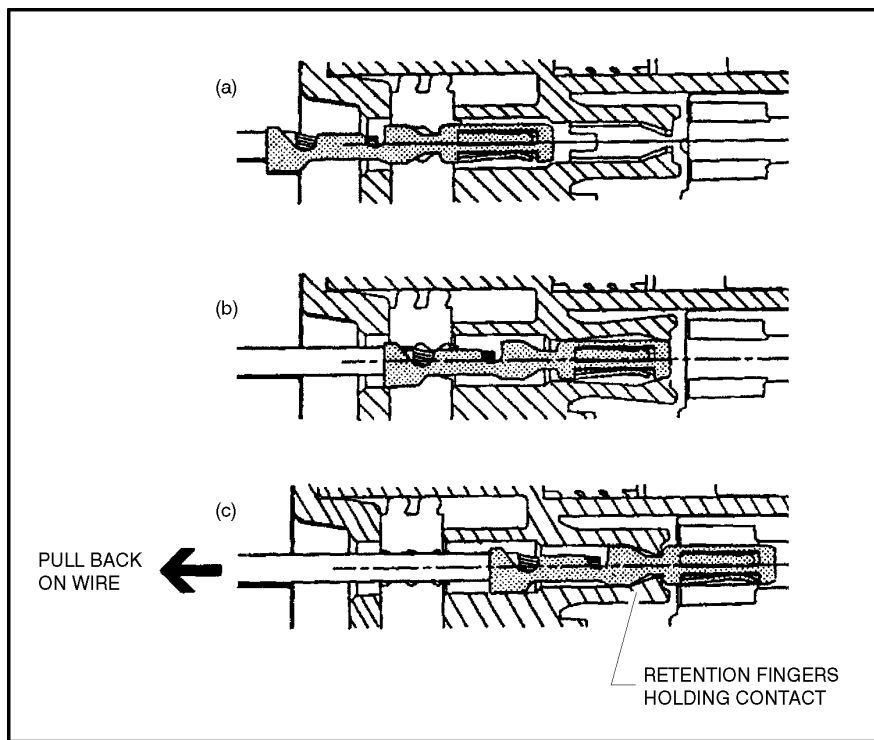

Figure 8-3. Connector Assembly Figure 2

3. After all required contacts have been inserted, the wedge lock must be closed to its locked position. Release the locking latches by squeezing them inward (See Figure 8-4.).

4. Slide the wedge lock into the housing until it is flush with the housing (See Figure 8-5.).

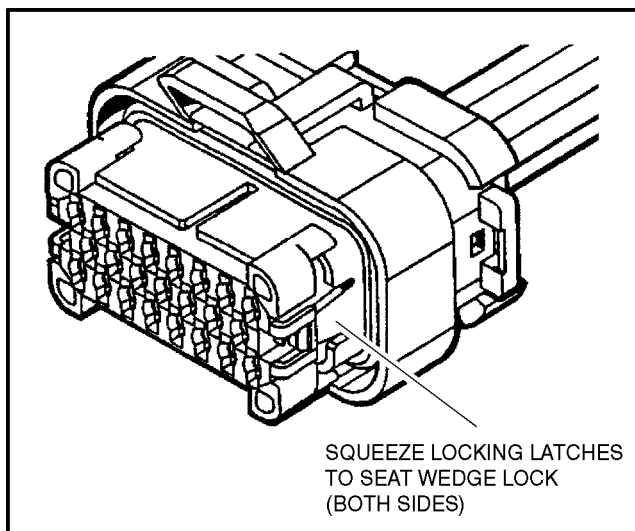

Figure 8-4. Connector Assembly Figure 3

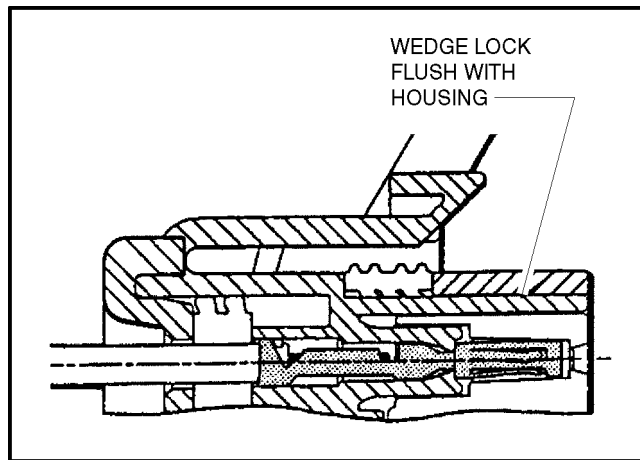

Figure 8-5. Connector Assembly Figure 4

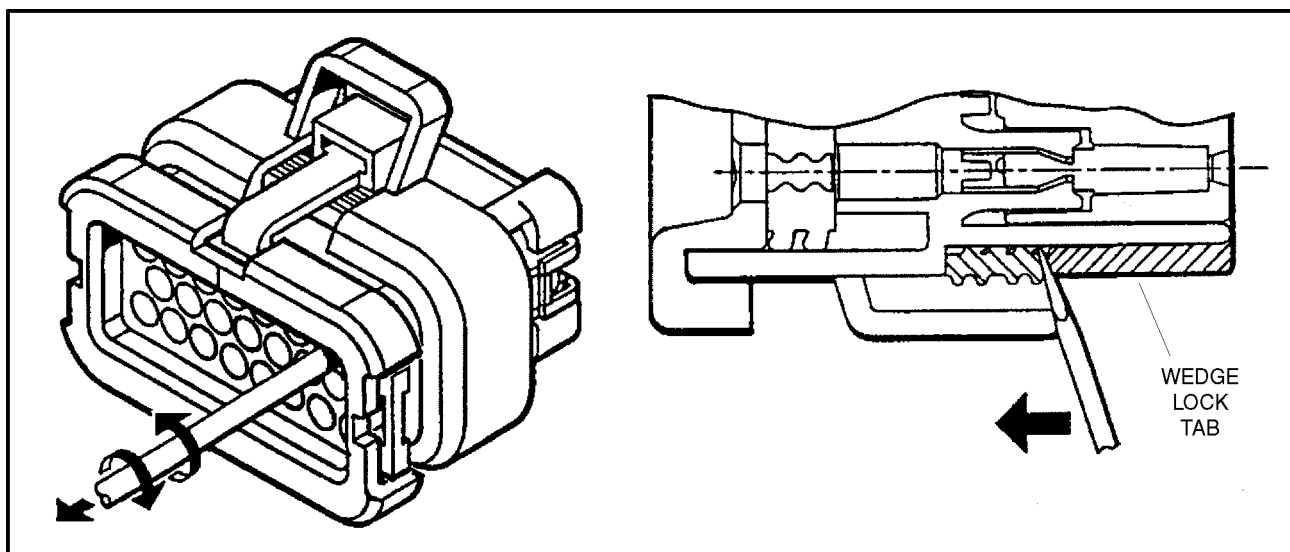

Figure 8-6. Connector Disassembly

Disassembly

1. Insert a 4.8 mm (3/16 in.) wide screwdriver blade between the mating seal and one of the red wedge lock tabs.
2. Pry open the wedge lock to the open position.
3. While rotating the wire back and forth over a half turn (1/4 turn in each direction), gently pull the wire until the contact is removed.

NOTE: The wedge lock should never be removed from the housing for insertion or removal of the contacts.

Wedge Lock

The wedge lock has slotted openings in the forward, or mating end. These slots accommodate circuit testing in the field, by using a flat probe such as a pocket knife. DO NOT use a sharp point such as an ice pick.

Service - Voltage Reading

⚠ CAUTION

DO NOT PIERCE WIRE INSULATION TO TAKE VOLTAGE READINGS.

It has been common practice in electrical troubleshooting to probe wires by piercing the insulation with a sharp point. This practice should be discouraged when dealing with the AMPSEAL plug assembly, or any other sealed connector system. The resulting pinholes in the insulation will allow moisture to invade the system by traveling along the wire strands. This nullifies the effectiveness of the connector seals and could result in system failure.

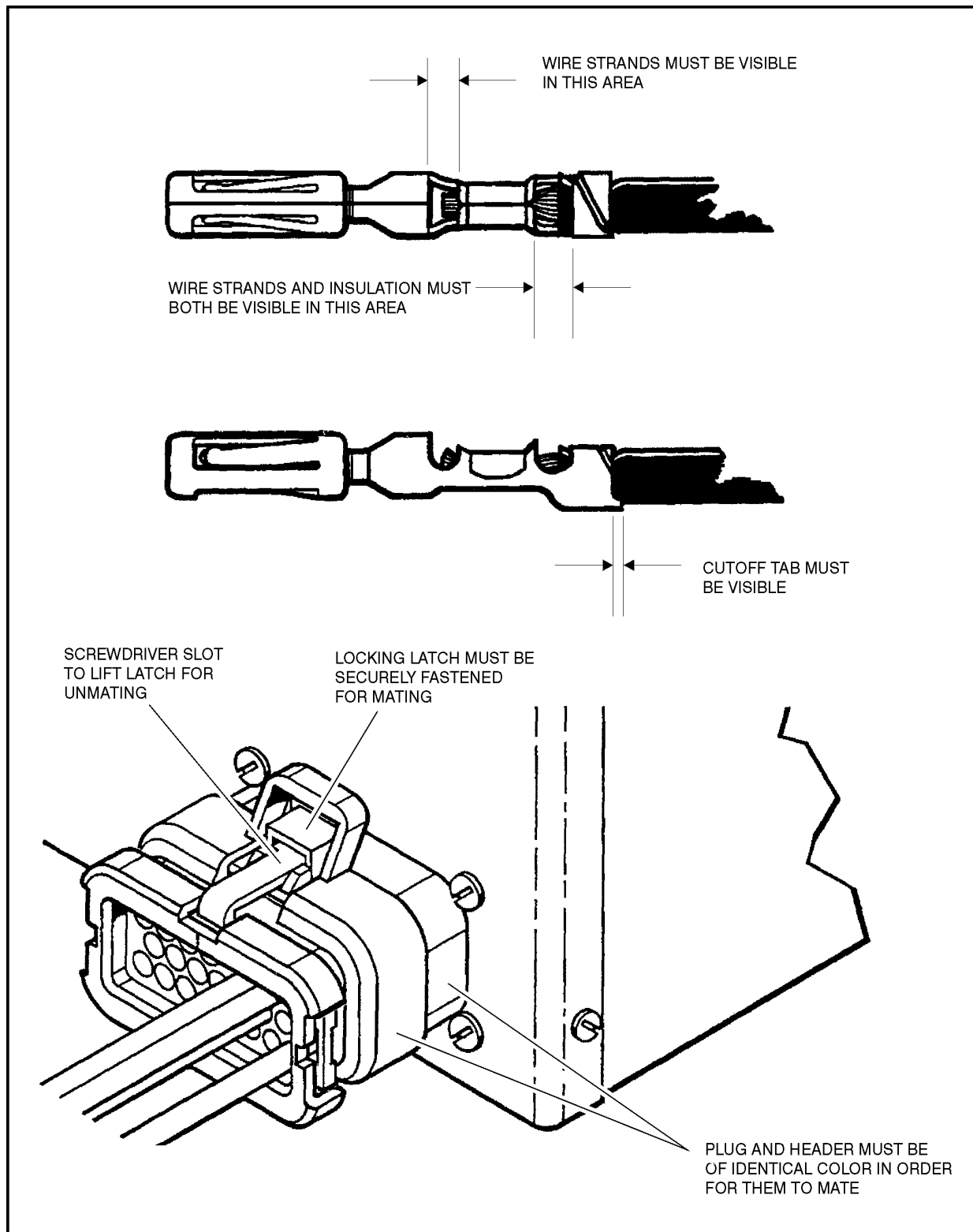

Figure 8-7. Connector Installation

8.6 DEUTSCH CONNECTORS

DT/DTP Series Assembly

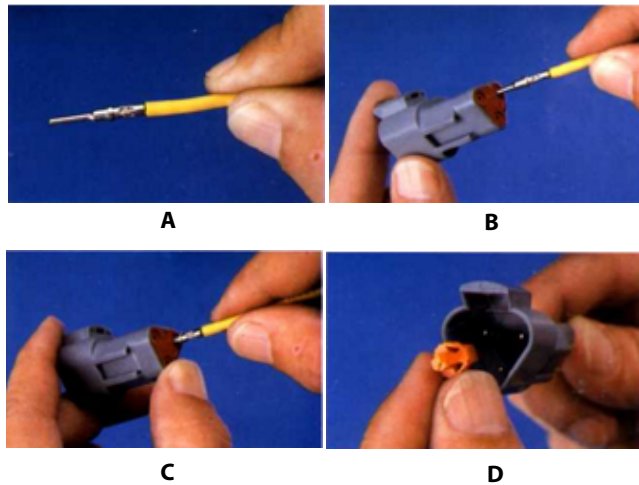

Figure 8-8. DT/DTP Contact Installation

1. Grasp crimped contact about 25mm behind the contact barrel.
2. Hold connector with rear grommet facing you.
3. Push contact straight into connector grommet until a click is felt. A slight tug will confirm that it is properly locked in place.
4. Once all contacts are in place, insert wedgelock with arrow pointing toward exterior locking mechanism. The wedgelock will snap into place. Rectangular wedges are not oriented. They may go in either way.

NOTE: The receptacle is shown - use the same procedure for plug.

DT/DTP Series Disassembly

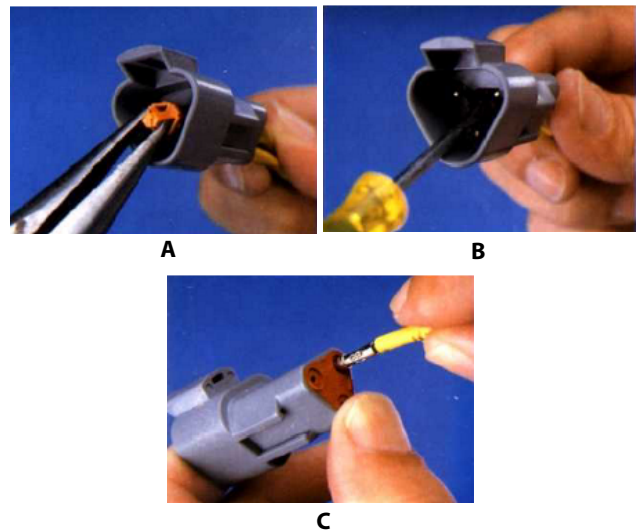

Figure 8-9. DT/DTP Contact Removal

5. Remove wedgelock using needle nose pliers or a hook shaped wire to pull wedge straight out.
6. To remove the contacts, gently pull wire backwards, while at the same time releasing the locking finger by moving it away from the contact with a screwdriver.
7. Hold the rear seal in place, as removing the contact may displace the seal.

HD30/HDP20 Series Assembly

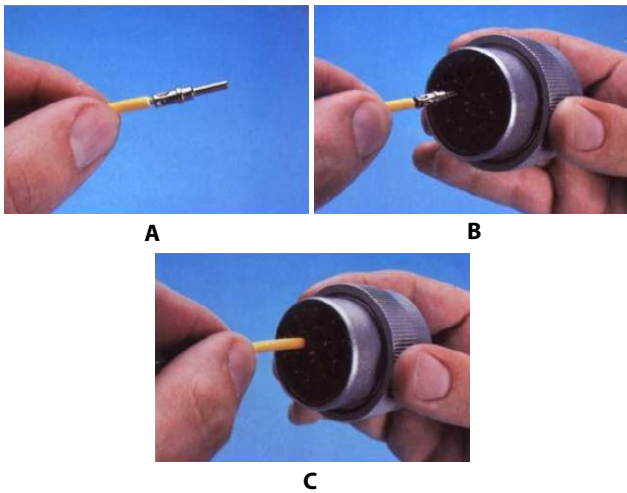

Figure 8-10. HD/HDP Contact Installation

1. Grasp contact about 25mm behind the contact crimp barrel.
2. Hold connector with rear grommet facing you.
3. Push contact straight into connector grommet until a positive stop is felt. A slight tug will confirm that it is properly locked in place.

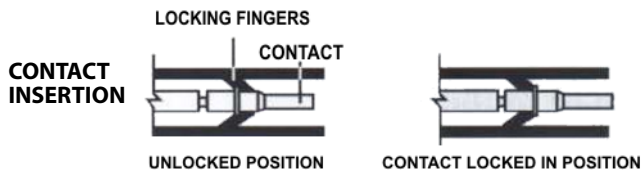

Figure 8-11. HD/HDP Locking Contacts Into Position

NOTE: For unused wire cavities, insert sealing plugs for full environmental sealing.

HD30/HDP20 Series Disassembly

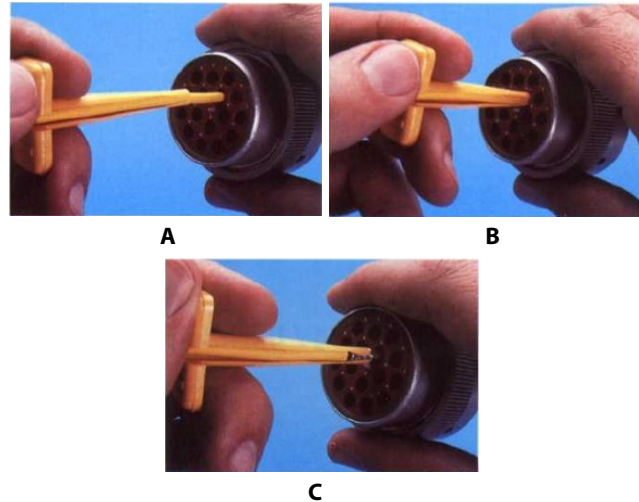

Figure 8-12. HD/HDP Contact Removal

4. With rear insert toward you, snap appropriate size extractor tool over the wire of contact to be removed.
5. Slide tool along into the insert cavity until it engages contact and resistance is felt.
6. Pull contact-wire assembly out of connector.



Figure 8-13. HD/HDP Unlocking Contacts

NOTE: Do Not twist or insert tool at an angle.

8.7 SWITCHES

Basic Check

The following check determines if the switch is functioning properly, not the circuit in which the switch is placed. A switch is functioning properly when there is continuity between the correct terminals or contacts only when selected.

1. De-energize the circuit.
2. Isolate the switch from the rest of the circuit if possible. If not possible, keep in mind it may affect readings.
3. Access the terminals to the switch.
4. If the switch has two terminals:
 - a. Measure resistance across the terminals.
 - b. Change the switch position.
 - c. Measure resistance again with the leads in the same positions. If the meter was reading short, it should read an open. If the meter was reading open it should read short.
5. If the switch has more than two terminals, consult the schematic or switch diagram to determine what terminals will be connected. The test is similar to testing a switch with two terminals.
 - a. Place one meter lead on the common contact and the other on a different contact in the same circuit.
 - b. Cycle through all positions of the switch. The meter should read short only when the switch connects the two terminals and open otherwise.
 - c. If the switch has more than one common contact repeat the process for that circuit.

Limit Switches

Limit switches are used to control movement or indicate position. Mechanical limit switches are just like manually operated switches except that the moving object operates the switch. These switches can be tested the same way as a standard switch by manually operating the sensing arm.

Another type of limit switch used by JLG is the inductive proximity switch, also referred to as a "prox switch". Inductive proximity switches are actuated only by ferrous metal (metal that contains Iron, such as steel) near the switch. They do not require contact, and must be energized to actuate. These types of switches can be used to detect boom or platform position, for example. These switches have a sensing face where the switch can detect ferrous metal close to it. To find the sensing face, take note how the switch is mounted and how the mechanisms meet the switch. Test this type of switch as follows:

1. Remove prox switch from its mount.
2. Reconnect harness if it was disconnected for step a, and turn on machine.
3. Hold switch away from metal and observe switch state in the control system diagnostics using the Analyzer. See vehicle or control system documentation on how to do this.
4. Place sensing face of switch on the object to be sensed by the switch. If that is not available, use a piece of ferrous metal physically similar to it. The switch state in the control system diagnostics should change.
5. When reinstalling or replacing switch be sure to follow mounting instructions and properly set the gap between the switch and object sensed.

Automatic Switches

If the switch is actuated automatically, by temperature or pressure for example, find a way to manually actuate the switch to test it. Do this either by applying heat or pressure, for example, to the switch. These switches may need to be energized to actuate.

1. Connect instrumentation to monitor and/or control the parameter the switch is measuring.
2. Observe switch state in control system with the Analyzer. See vehicle or control system documentation on how to do this.
3. Operate system such that the switch actuates. This could be going over a certain pressure or temperature, for example. The state indicated in the control system should change.

Switch Wiring - Low Side, High Side

When controlling a load, a switch can be wired between the positive side of the power source and the load. This switch is called a "high side" switch. The switch supplies the power to the load. When a switch is wired between the negative side of the power source and the load, it is a "low side" switch. The switch provides the ground to the load.

A low side switch will allow voltage to be present on the load. No power is applied because the switch is stopping current flow. This voltage can be seen if the measurement is taken with one test lead on the load and the other on the battery negative side or grounded to the vehicle. What is actually being measured is the voltage drop across the switch. This could mislead a technician into thinking the load is receiving power but not operating. To produce an accurate picture of power or voltage applied to the load, measure voltage across the load's power terminals. Also, the technician can measure the voltage at both power terminals with respect to battery ground. The difference between those two measurements is the voltage applied to the load.

8.8 ELECTRICAL SCHEMATICS

SHEET 2:

HARNESS, CHASSIS
HARNESS, LIFT DOWN
KIT, BATTERY CABLE
CABLE, PUMP POS
CABLE, PUMP NEG

SHEET 3:

CABLE, PLATFORM /AC
CABLE, PLATFORM CONTROL
CABLE, PLATFORM CONTROL (COILED)
CABLE, PLATFORM CONTROL W/FTSW
CABLE, PLATFORM CONTROL (COILED) W/FTSW
HARNESS, PLATFORM BOX
HARNESS, OVERHEAD PROTECTION

SHEET 4:

BEACON (DUAL)
CHARGER INTERLOCK
CHARGER DC CONNECTION - DELTA-Q
CHARGER DC CONNECTION - GREEN / EAGLE
INVERTER
INVERTER HARNESS
BATT+ TO INV CONTACTOR CABLE
PUMP CTRL B- TO INV
INV CONTACTOR TO INV+ CABLE
INVERTER TO AC FILTER
AC FILTER TO AC PLUG
HARNESS, MOBILE CONTROL
HARNESS, REMOTE TOW

SHEET 5:

HARNESS, RSCISSOR CLEARSKY CAN
HARNESS, RSCISSOR CAN SPLICE
HARNESS, CHARGER, 24VDCT

SHEET 1

1001233001-C

Figure 8-14. Electrical Schematic - Sheet 1 of 9

SECTION 8 - BASIC ELECTRICAL INFORMATION & SCHEMATICS

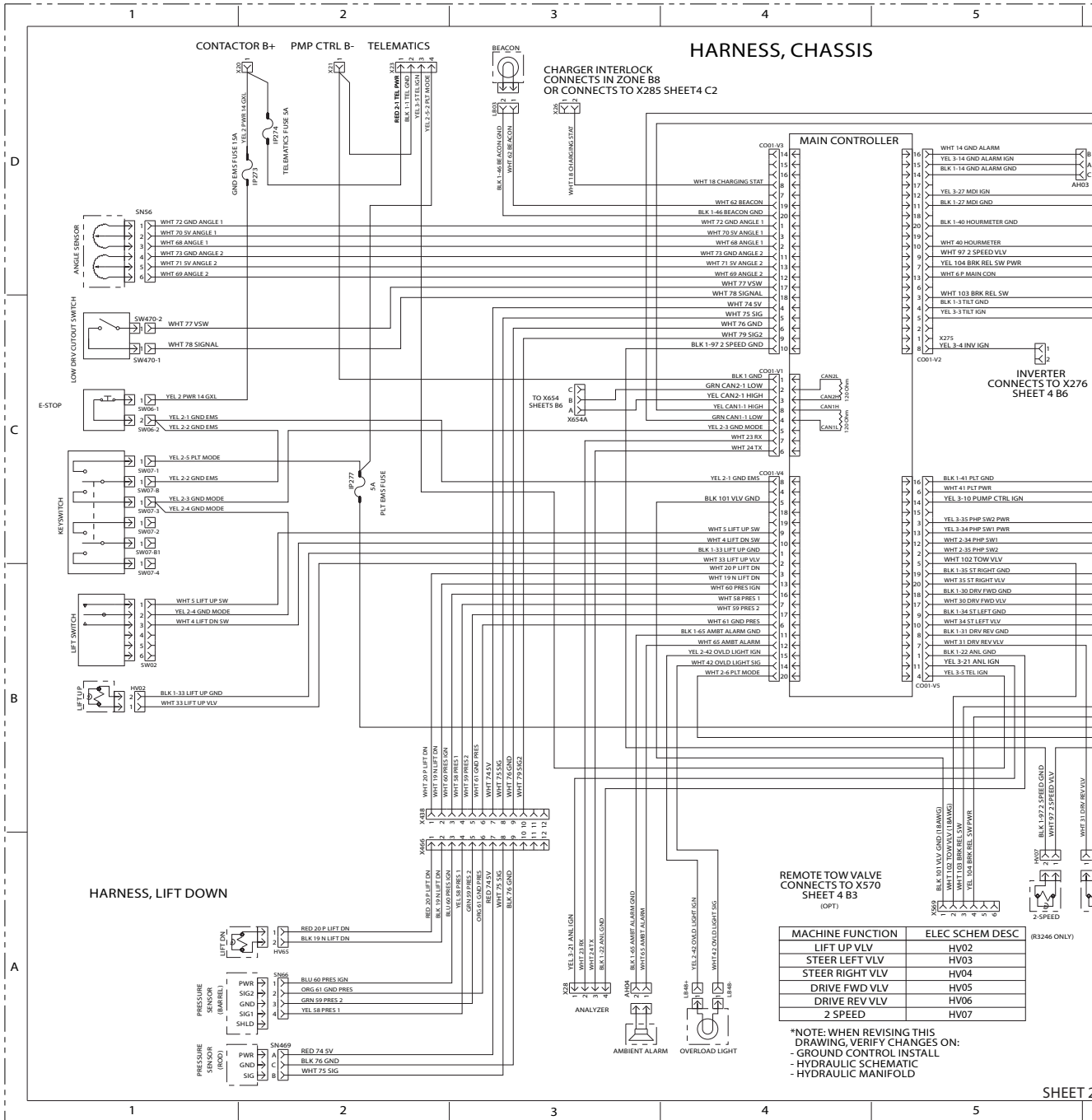
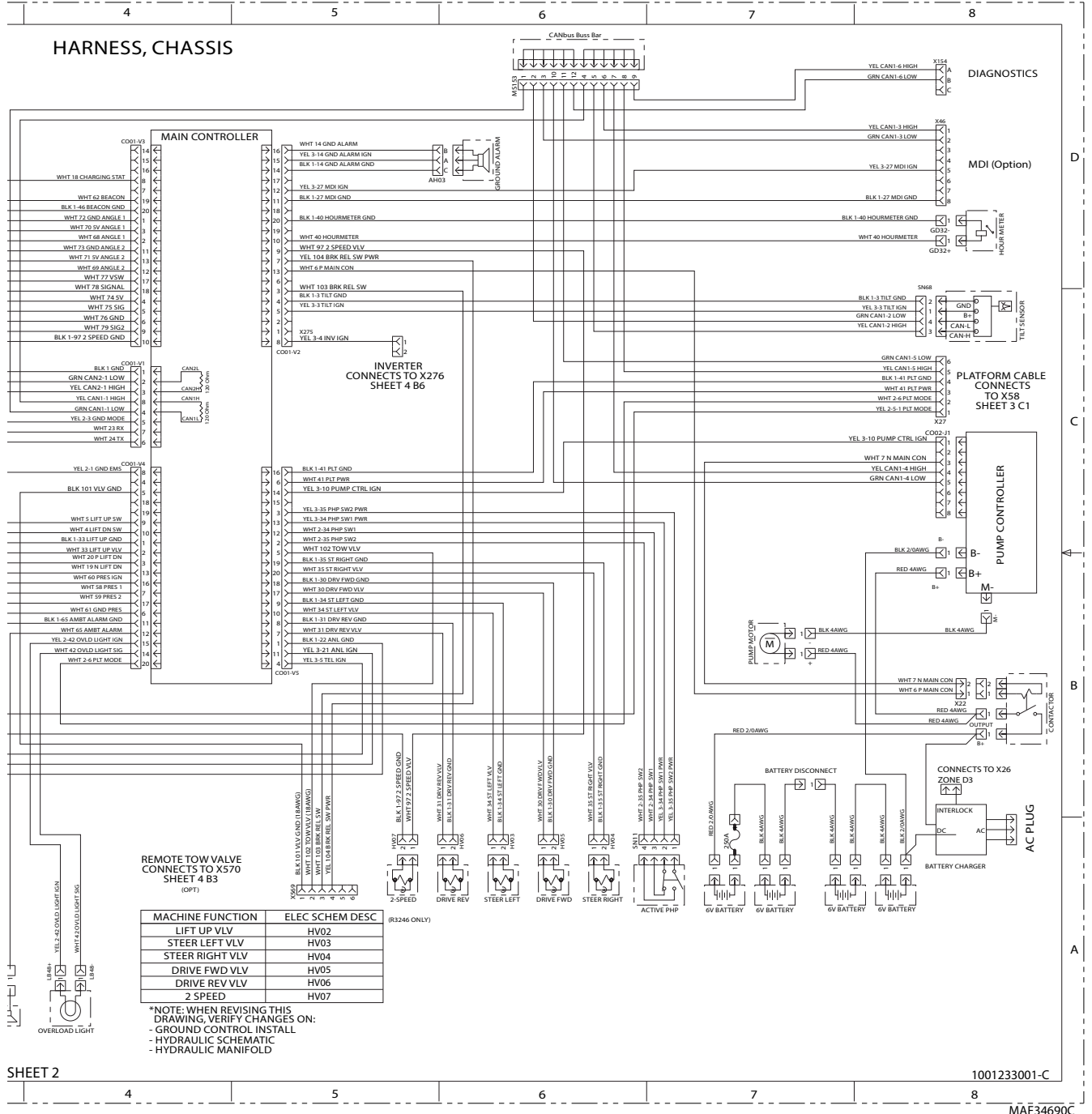

Figure 8-15. Electrical Schematic - Sheet 2 of 9



SHEET 2

1001233001-C

MAF34690C

Figure 8-16. Electrical Schematic - Sheet 3 of 9

SECTION 8 - BASIC ELECTRICAL INFORMATION & SCHEMATICS

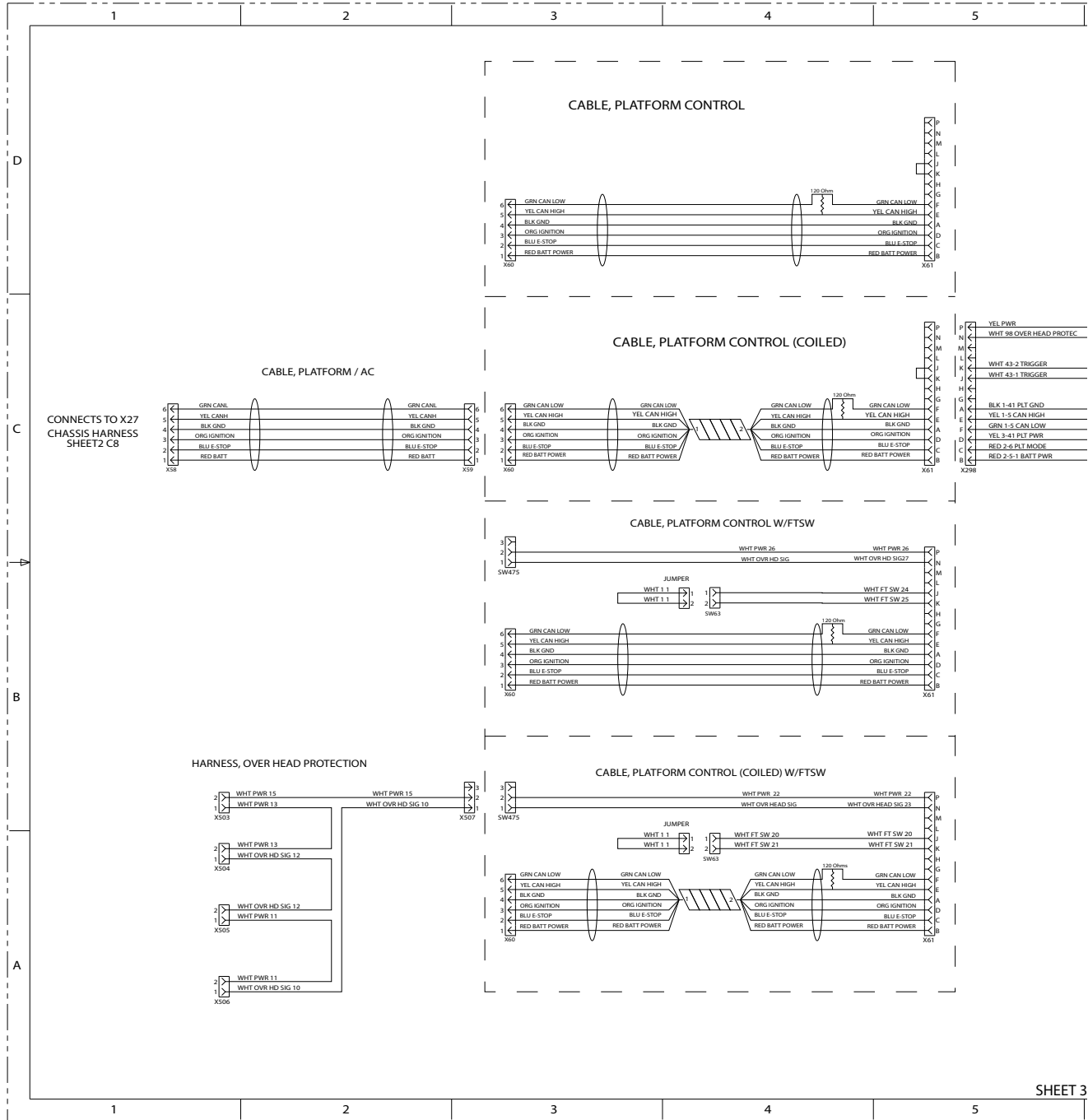

SHEET 3

Figure 8-17. Electrical Schematic - Sheet 4 of 9

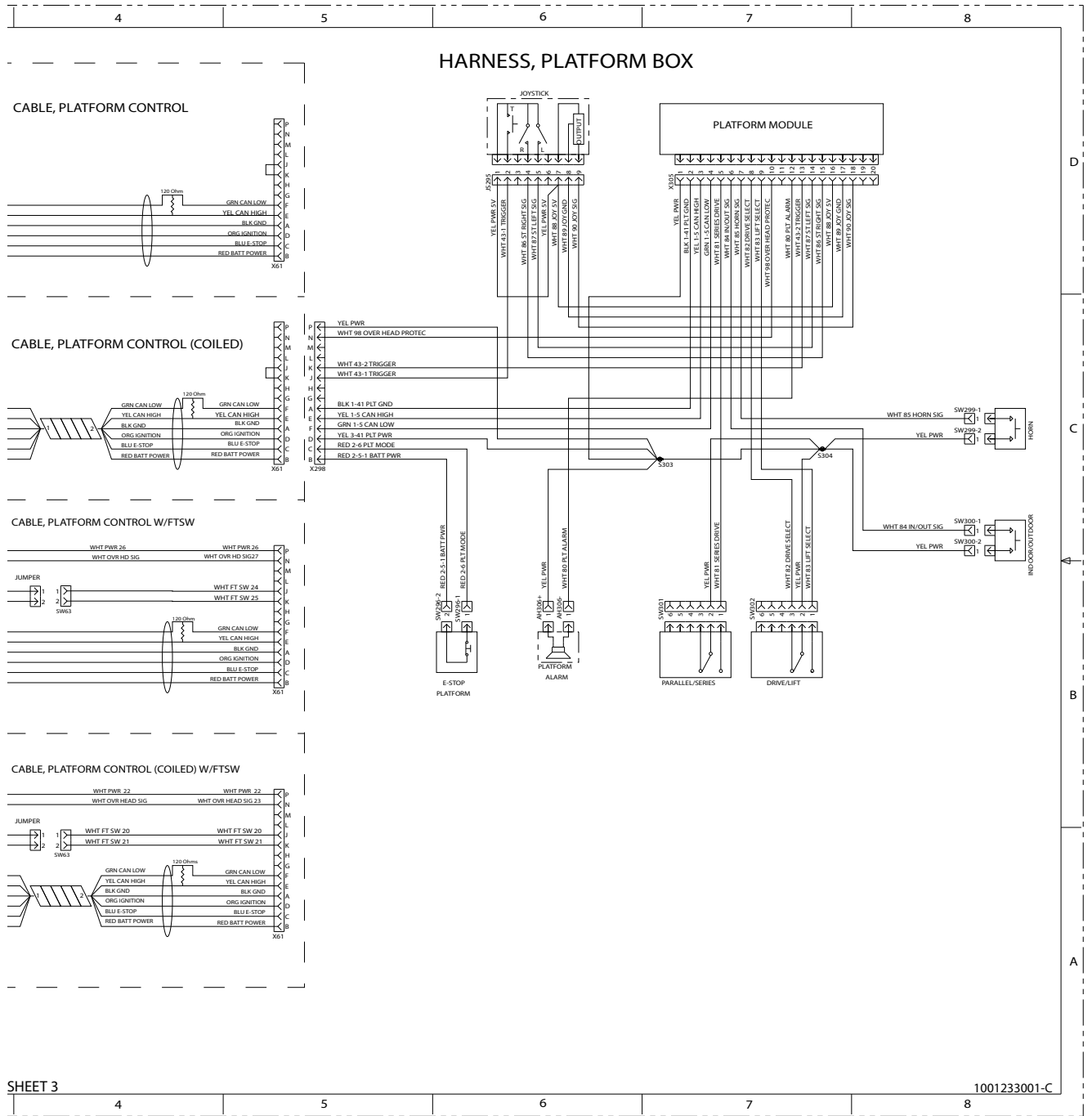

Figure 8-18. Electrical Schematic - Sheet 5 of 9

SECTION 8 - BASIC ELECTRICAL INFORMATION & SCHEMATICS

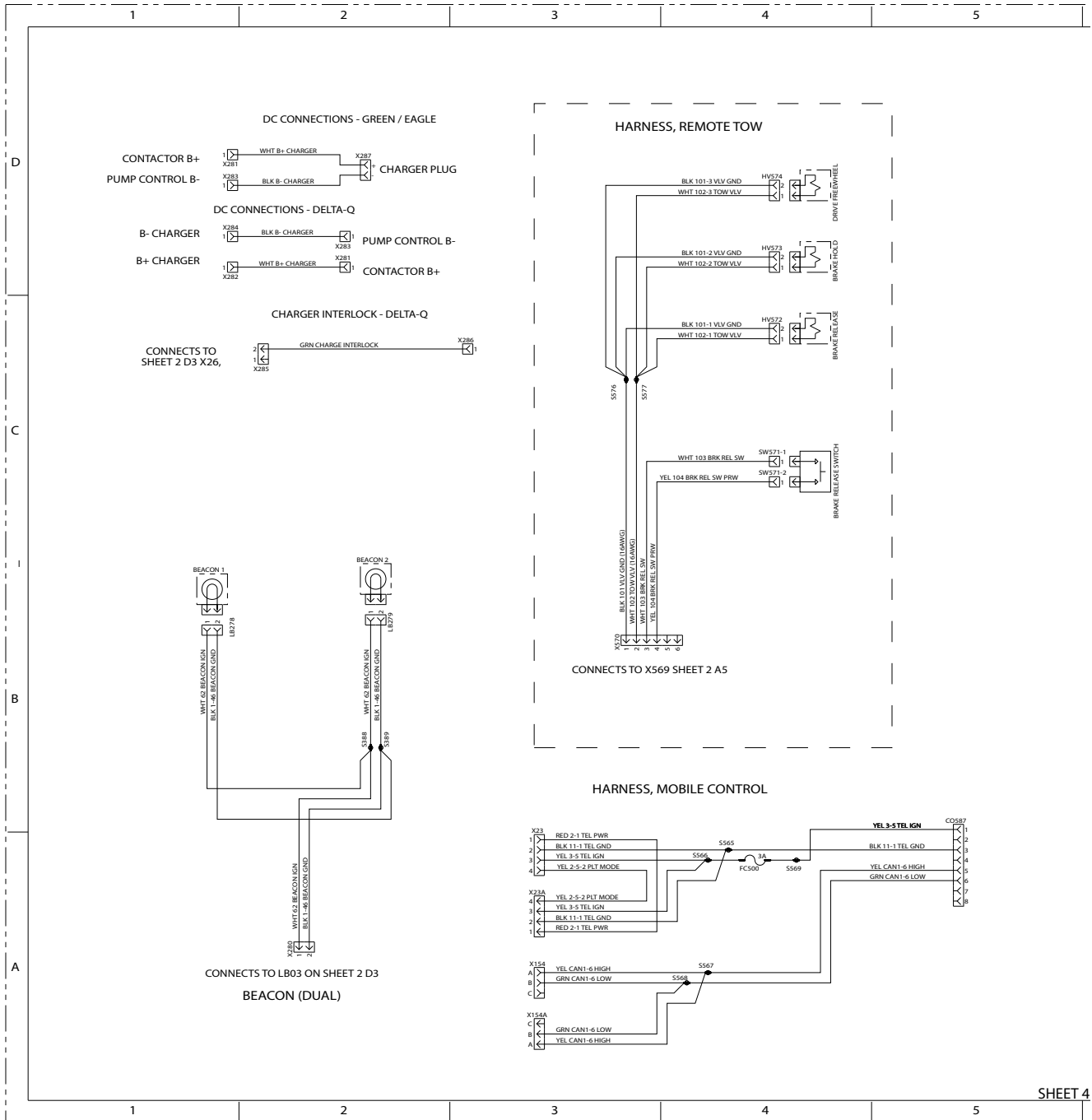

Figure 8-19. Electrical Schematic - Sheet 6 of 9

SECTION 8 - BASIC ELECTRICAL INFORMATION & SCHEMATICS

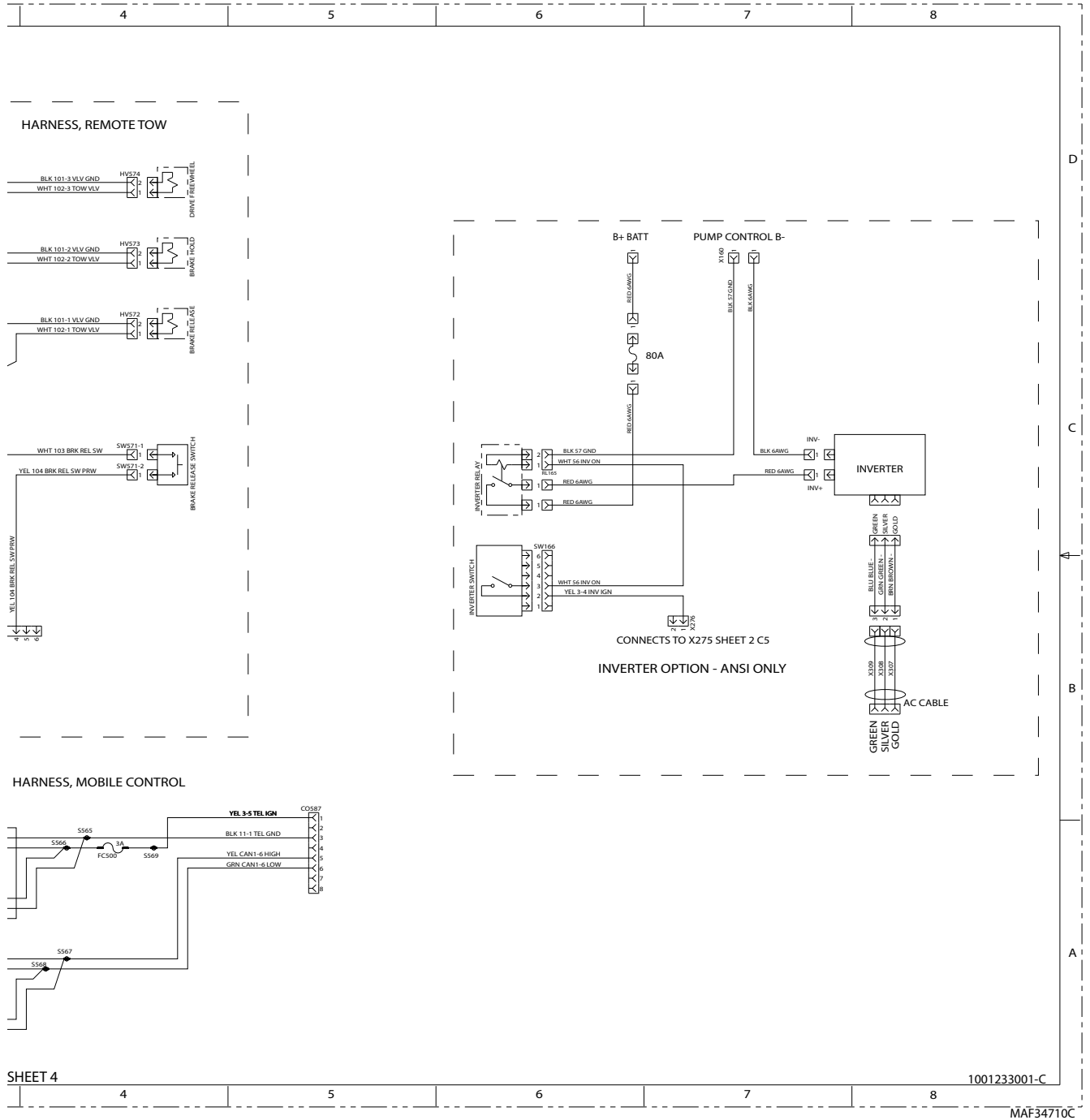

Figure 8-20. Electrical Schematic – Sheet 7 of 9

SECTION 8 - BASIC ELECTRICAL INFORMATION & SCHEMATICS

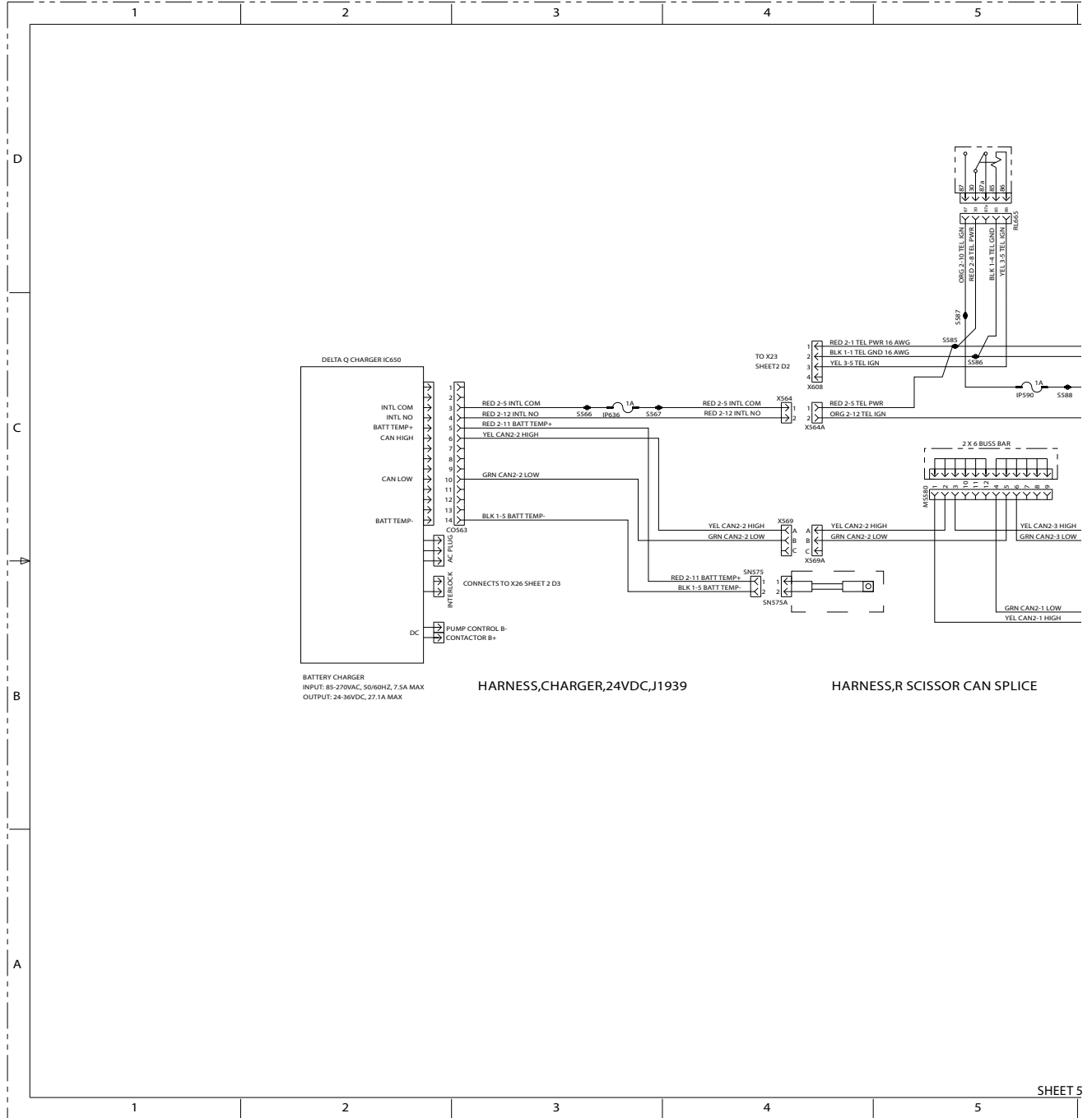

Figure 8-21. Electrical Schematic – Sheet 8 of 9

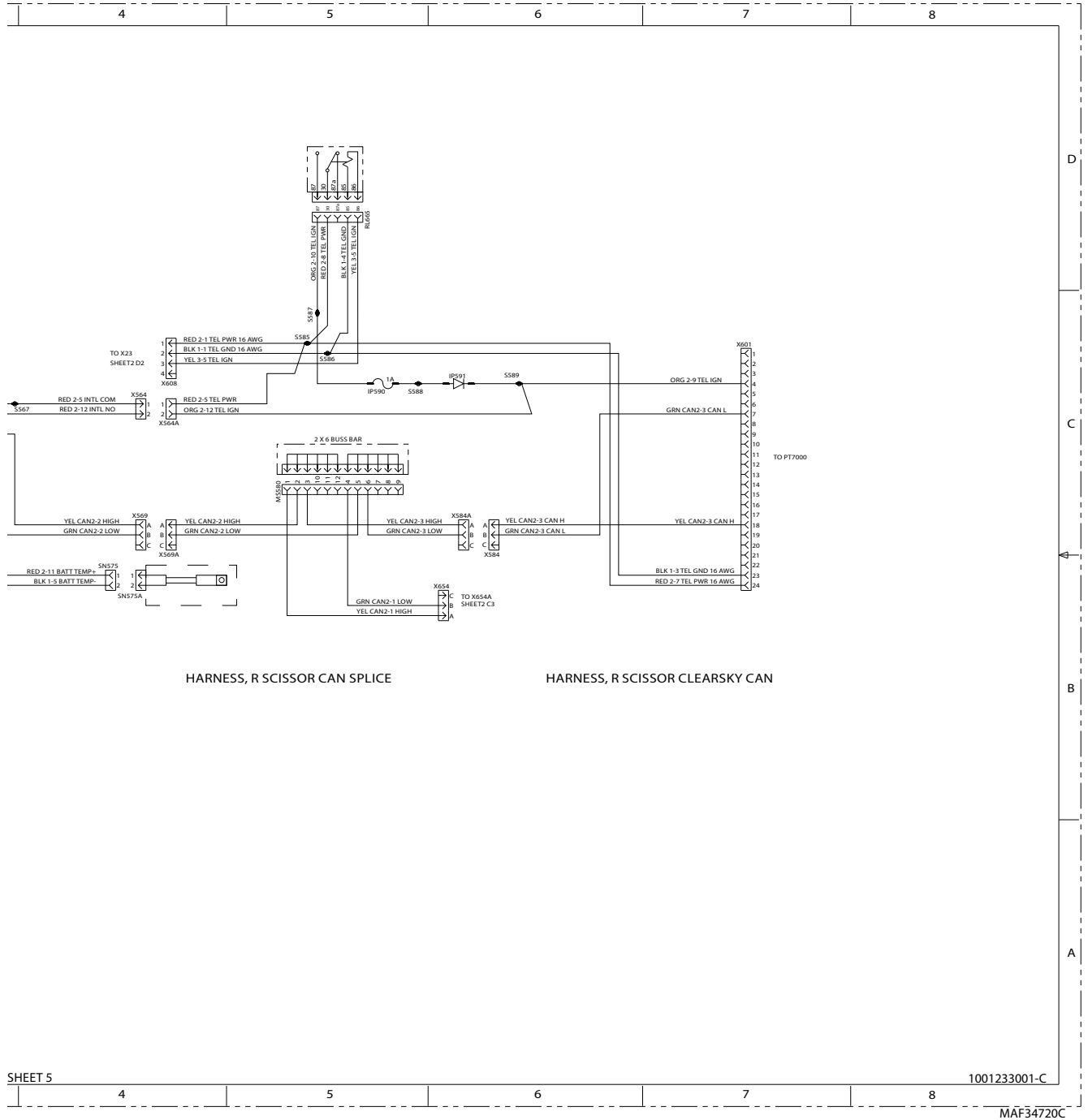

Figure 8-22. Electrical Schematic – Sheet 9 of 9



An Oshkosh Corporation Company

Corporate Office
JLG Industries, Inc.
1 JLG Drive
McConnellsburg, PA 17233-9533 USA
☎ (717) 485-5161 (Corporate)
☎ (877) 554-5438 (Customer Support)
☎ (717) 485-6417

Visit our website for JLG Worldwide Locations.
www.jlg.com